



Gas detection unit

Basic

Type GD Basic and Basic+
Next generation gas detection for industrial refrigeration

Description

The Basic and Basic+ gas detection units are used for monitoring and warning of hazardous gas concentrations. They can be used for detecting commonly used refrigerants.

The Basic and Basic+ gas detection units are intended to be connected to a central system like Gas Detection Controller Unit, or a PLC, by either Analog or RS485 open Modbus communications. The central system converts the alarm signal from the Basic unit to activation of alarm devices.

The gas detection units come with a factory default, 2-step alarm set-up ready for use. The integrated software enables the user to configure two individual alarm ranges. Alarm 1, a pre-alarm indicating the gas level has passed a predefined threshold 1, and - if the gas level passes predefined threshold 2 - the final alarm 2.

Features & benefits

- Digital, factory configured and pre-calibrated gas detectors for plug-and-play installation (no adjustment required)
- Easy configuration via intuitive user-interface; helps simplify operator handling and minimize risk of operational, settings and calibration errors
- Flexible connection - by either Analog or RS485 open Modbus communications
- Fieldbus wiring - connect and power up to 96 sensors, wire length max. 900 meter per segment; expansion modules permit additional segments
- Automatic self-diagnostics to ensure correct communication and operation
- Sensor seal cap to prevent premature exposure during installation
- Digital user interface ensures higher sensor accuracy and reduced risk of false alarms due to temperature compensated sensors
- Password protected alarm settings allowing authorized access only
- LED status signals and alarms along with Buzzer & Light option for local audio and visual alarms (Basic+)
- On-board acknowledge button to reset alarms and to verify the that no gas leaks are present

Ordering

Product code numbers

Type	Model	Refrigerant	Sensor	ppm range	Alarm ppm	Temp. Range [°C]	Temp. Range [°F]	Code number
GDA	Basic	Ammonia	Electrochemical	0 – 100	25/35	-40 – +50	-40 – +122	148H6000
	Basic+ ⁽¹⁾	Ammonia	Electrochemical	0 – 100	25/35	-40 – +50	-40 – +122	148H6001
	Basic	Ammonia	Electrochemical	0 – 300	25/150	-40 – +50	-40 – +122	148H6008
	Basic+ ⁽¹⁾	Ammonia	Electrochemical	0 – 300	25/150	-40 – +50	-40 – +122	148H6009
	Basic	Ammonia	Electrochemical	0 – 1000	500/900	-40 – +50	-40 – +122	148H6014
	Basic+ ⁽¹⁾	Ammonia	Electrochemical	0 – 1000	500/900	-40 – +50	-40 – +122	148H6015
	Basic	Ammonia	Semiconductor	0 – 1000	500/900	-40 – +50	-40 – +122	148H6023
	Basic+ ⁽¹⁾	Ammonia	Semiconductor	0 – 1000	500/900	-40 – +50	-40 – +122	148H6024
	Basic	Ammonia	Semiconductor	0 – 10000	5000/9000	-40 – +50	-40 – +122	148H6071
	Basic Remote	Ammonia	Semiconductor	0 – 10000	5000/9000	-40 – +50	-40 – +122	148H6073
	Basic	Ammonia	Pellistor	0 – 140000	30000	-40 – +50	-40 – +122	148H6070
	Basic	Ammonia	Pellistor	0 – 28000	14000/25000	-40 – +50	-40 – +122	148H6080
Basic Remote	Ammonia	Pellistor	0 – 28000	5000/9000	-40 – +50	-40 – +122	148H6081	
GDHF	Basic	R32, R125, R143A, R404A, R407C, R410A, R434A, R448A, R452B, R507A	Semiconductor	0 – 2000	500/900	-40 – +50	-40 – 122	148H6045
	Basic+ ⁽¹⁾	R32, R125, R143A, R404A, R407C, R410A, R434A, R448A, R452B, R507A	Semiconductor	0 – 2000	500/900	-40 – +50	-40 – 122	148H6046
GDC	Basic	CO ₂	Infrared	0 – 20000	5000/9000	-40 – +50	-40 – 122	148H6072

⁽¹⁾ incl buzzer & Light

Accessories code numbers

Accessories overview

Controller unit

Used for a centralized monitoring and warning. The input signals for the controller are collected via RS485 Modbus or analog communication. The controller can handle up to 96 digital sensors via Fieldbus and four (4) analog input. An additional 28 analog input is possible using seven (7) expansion modules (4 – 20 mA signal interface). The total number of connected sensors should not exceed 128 sensors. The controller unit can be employed as pure analog controller, as analog/digital, or as digital controller. Configuration is menu-driven via the keypad. For fast and easy configuration, the PC tool is recommended.

Controller solution

Controller unit placed in an enclosure ready to be connected to a power source. A separate UPS for the controller is available.

Controller expansion module

The gas detection controller expansion module is used for expansion of the cable coverage in terms of number of loops and the total wire length. Each controller Unit can handle up to 7 Expansion modules allowing additional 7 segments with a total of 7200 meters (23622 ft.) wiring and a total of 32 relays for alarm device circuits.

Service tool

For interface with units with no display (Basic, Basic+, Premium, Premium+). Acts as a portable display and can be connected to all Danfoss gas detection units. (Heavy Duty w. adapter).

PC tool

The PC tool is a menu-driven and standalone software used for easy addressing, parameter setting, calibration, and data logging of the Basic, Premium and Heavy-Duty gas detection units, and the controller unit.

Calibration adapter

The calibration adapter is required for connecting the calibration gas container, via the flow regulator, to the sensor head on the gas detection units. (Two variants, One for Basic and Premium plastic head sensors; one for heavy duty and Premium remote metal head sensors).

Buzzer & light - acoustic buzzer and optic led

Can be installed in Basic or Premium units providing a local alarm.

Air duct set

The air duct set is specially designed to capture the airflow in air ducts. It can be connected to the standard sensor heads, except from Heavy Duty gas detection units.

Seal cap

Airtight seal cap to protect the sensor head against premature exposure during installation. The seal cap is mounted on new sensors (complete units and replacement sensors) but is also available as an accessory.

Splash guard

To protect the sensor head against water exposure during wash-down cleaning and rinsing operations.

Gateway for controller

The gateway is an addition to the controller and used for communicating via Modbus TCP/IP.

Remote kit

Enabling installation of a sensor head in plastic housing 5m (16.4 ft.) from the unit. This means that the gas detection unit can be placed outside the room where the sensor is placed to detect hazardous gases, allowing reading of and interfacing with the unit without entering the dedicated space. Basic and Premium gas detection units.

Spare parts code numbers

Table: Spare parts and accessories

Description	Code number
Replacement sensor - Ammonia EC 100	148H6200
Replacement sensor - Ammonia EC 300	148H6201
Replacement sensor - Ammonia EC 1000	148H6202
Replacement sensor - Ammonia SC 1000	148H6203
Replacement sensor - HFC R404A, R507 SC 2000	148H6210
Replacement sensor - HFC R1234yf SC 2000	148H6239
Replacement sensor - HFC R134a SC 2000	148H6211
Replacement sensor - CO ₂ IR 20000	148H6207
Replacement remote sensor - Ammonia P 28000	148H6257
Replacement sensor - Ammonia P 28000	148H6258
Controller unit	148H6231
Controller solution (controller + enclosure)	148H6221
Controller expansion module	148H6222
Service tool	148H6224
PC tool	148H6235
Calibration adapter	148H6232
Buzzer & light - acoustic buzzer and optic led	148H6225
Air duct set	148H6236
Seal cap	148H6227
Splash guard	148H6226
Gateway for controller	148H6228
Remote kit	148H6238

Functions

Working principle/Operation

One sensor can be connected to the Basic/Basic+ sensor board via local bus. The sensor board provides the power supply of the sensor and prepares the measured data for digital communication.

The operation menu of the Basic/Basic+ software is accessed through the dedicated GD service tool (or PC tool). The Service tool (or PC tool) is plugged directly to the board of the unit. The interfaces allow the unit configuration, setting of the unit alarm levels and calibration of the attached sensor.

The service tool (or PC tool) can be used on all units across the Basic, Premium and Heavy-Duty platforms.

The alarm signals can be handled by the Gas Detection Controller (or a PLC) via the 4 – 20 mA (2 – 10V) analog output or the RS485 open Modbus communication. For additional operational safety the changing of parameters is password protected allowing authorized access only. The factory default password can easily be customized.

Product details

General data

Electrical

Details	Description
Power supply	19 – 29 V AC/DC, DC reverse-polarity protected (selected units 100 – 240 V AC)
Power consumption (24 V DC)	Max. 250 mA (6 VA)

Outgoing line local bus

Details	Description
Power supply	5 V DC, 250 mA max., overload, short-circuit and reverse-polarity protected

Serial interface

Details	Description
Local bus	1-wire / 19200 baud
Fieldbus	RS 485 / 19200 baud
Tool bus	2-wire / 19200 baud

General

Details	Description
Temperature range	-40 – +50 °C (-40 – 122 °F)
Humidity range	15 – 90 % RH not-condensing
Storage temperature	+5 – +30 °C (41 – 86 °F)
Storage time	12 months

Physical

Details	Description
Housing	Type A
Material	Polycarbonate
Burning behaviour	UL 94 V2
Housing colour	Black
Dimensions (W x H x D in mm)	94 x 130 x 57
Weight (kg)	Approx. 0.3kg (0.8 lbs.)
Protection class	IP65
Installation	Wall mounting
Cable entry	2 x M12 / 3 x M20
Wire connection:	
Power supply, fieldbus	Screw-type terminals 0.25 – 2.5 mm ² (25 AWG to 14 AWG)
Analog output	Screw-type terminals 0.25 – 1.3 mm ² (25 AWG to 17 AWG)
Local bus for sensor	3-pin plug connector
Cable lengths local bus for remote sensor board	Max. 5 m (16.4 ft.)

Analog output signal

Description
Proportional, overload and short-circuit proof, load ≤ 500 Ohm
4 – 20 mA = measuring range
3.0 < 4 mA = under range
> 20 – 21.2 mA = overrange
2.0 mA = fault (configurable)

Status LED / Buzzer & light (only Basic+)

Details	Description
Colour	3 color light: Green, yellow, red
Acoustic pressure	> 85 dB (A) (0.1 m distance)
Frequency	2300 Hz
Protection class	IP65

Design

General information

Figure: GD Basic and Basic+

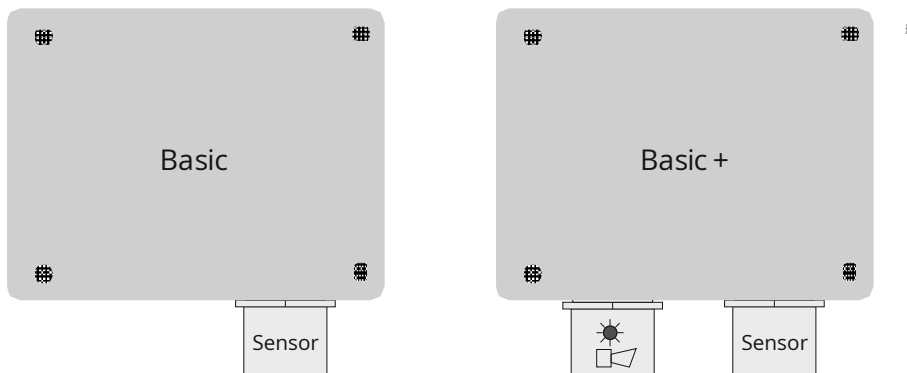

- Cable gland not mounted but enclosed
- 4 mounting ears included
- Sensor head mounted bottom right
- Alarm device (Buzzer & Light) mounted bottom left (only Basic +)

Table: Gas types and thresholds

Sensor	Sensor Type	ppm range	Alarm 1	Alarm 2	Hysteresis
Ammonia EC 100	Electrochemical	0 – 100 ppm	25 ppm	35 ppm	2 ppm
Ammonia EC 300	Electrochemical	0 – 300 ppm	25 ppm	150 ppm	2 ppm
Ammonia EC 1000	Electrochemical	0 – 1000 ppm	500 ppm	900 ppm	25 ppm
Ammonia SC 1000	Semiconductor	0 – 1000 ppm	500 ppm	900 ppm	25 ppm
HF R1234yf SC 2000 (FR3)	Semiconductor	0 - 2000 ppm	500 ppm	900 ppm	25 ppm
HFC R134a SC 2000 (FR7)	Semiconductor	0 - 2000 ppm	500 ppm	900 ppm	25 ppm
HFC R404A, R507 SC2000	Semiconductor	0 – 2000 ppm	500 ppm	900 ppm	25 ppm
Ammonia SC 10000	Semiconductor	0 – 10000 ppm	5000 ppm	9000 ppm	250 ppm
Ammonia P LEL	Pellistor	0 – 100% LEL (0 – 140000)	21% LEL (30000 ppm)	21% LEL (30000 ppm)	1%
CO₂ IR 20000 (2% Vol.)	Infrared	(0 – 2% Vol) (0 – 20000 ppm)	0.5% Vol (5000 ppm)	0.9% Vol (9000 ppm)	0.025% vol (250 ppm)

NOTE:

Hysteresis = 5% of Alarm1 (rounded up to the next higher integer)

LEL/LFL = Lower explosive limit / Lower flammability limit

Connections

Electrical connection

- Relays (Rel. 1 and Rel. 3) cannot be used

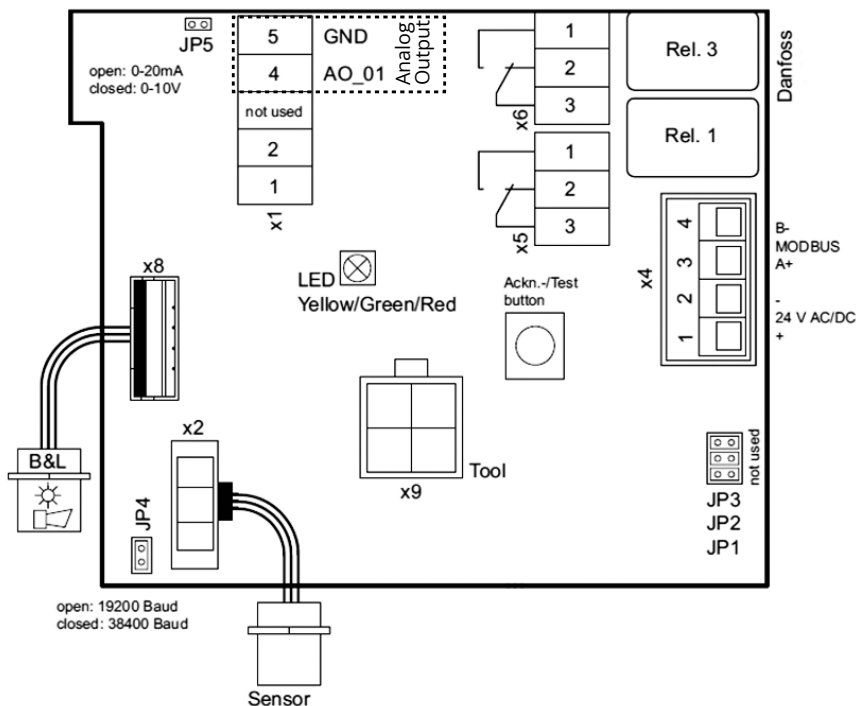

Status LED:

- GREEN is power on
 - flashing if maintenance needed
- YELLOW is an indicator of Error
 - when the sensor head is disconnected or not the expected type
 - AO is activated but nothing connected
 - flashing when sensor is in special mode (e.g. when changing parameters)
- RED on alarm, similar to the buzzer & light alarm

Ackn. -/Test button:

TEST:

- The button must be pressed for 20 sec
- Alarm1 and Alarm2 is simulated, stop on release

ACKN:

- Pressed while Alarm2, the audible warning switches off and goes back on after 5 min. when the alarm situation is still active

* JP5 open → AO 4 – 20 mA (Default)

* JP5 closed → AO 2 – 10 Volt

NOTE:

A resistor comes installed on the analog output connections – if analog output is used, remove the resistor.

Fieldbus loop

Each GD controller can handle up to 96 sensors and handle any mix of individual Gas detection units of the types Basic, Premium and Heavy Duty.

The max. recommended loop wire length is 900 meter (2953 ft) per segment.

With additional segments (and additional controller expansion modules) the max recommended loop wire length is 7200 meter (23622 ft).

The controller and the last GDU in each segment must be provided with a resistor of 560 Ohm (Danfoss GD controller already includes the needed resistor). A U_{min} of 16 V DC must be secured at any spot in the loop.

Figure: How to make proper connections between the controller and each GDU

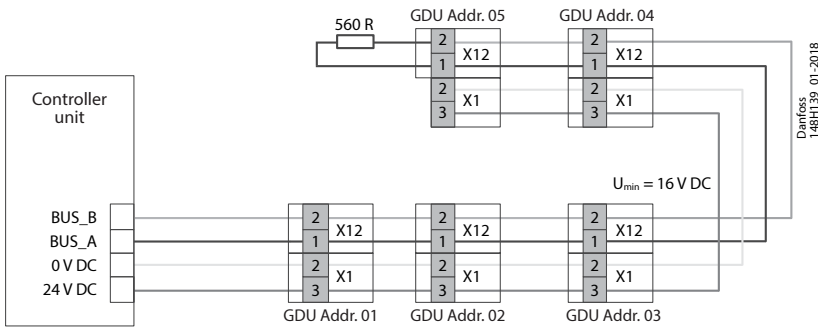
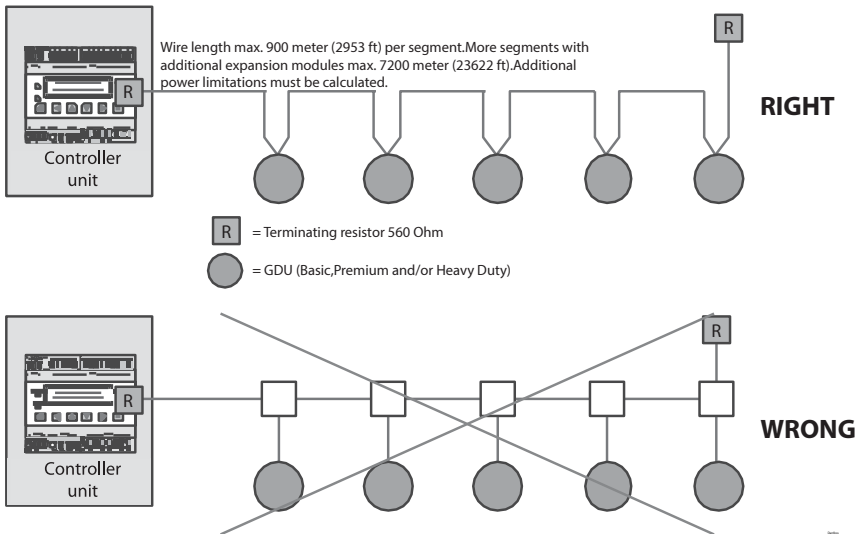
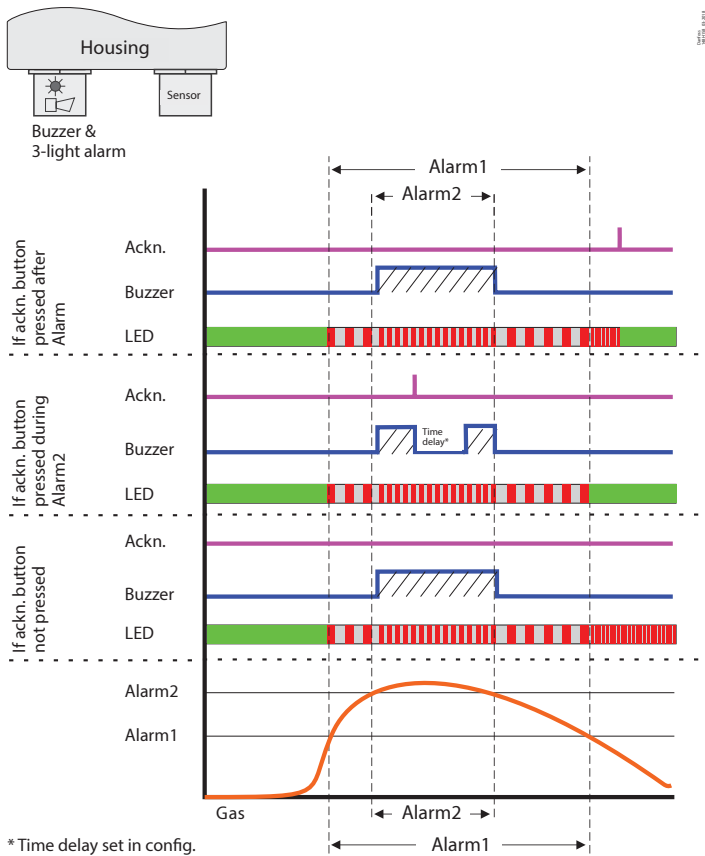

Figure: How to make proper connections between the controller and each GDU



Alarm scheme



Buzzer & light

	Blinking (2 sec.)
	Fast blinking (1 sec.)
	Very fast blinking (0.1 sec.)
	Buzzer on
	Static, Power LED

Service

Service and maintenance

The Basic/Basic+ gas detection units are calibrated either by replacing of sensor heads or by calibration with gas.

Plug & Play replacement sensors are pre-calibrated, and factory certified for quick and easy calibration procedure. The sensor is connected to the local bus via a plug connection enabling easy and simple exchange of sensor instead of an on-site calibration. The internal X-change routine recognizes the exchanged sensor during the exchange process and restarts the measurement mode automatically. An LED indicates the correct procedure of the exchange operation. To ensure the proper functioning of the units and to prevent human errors, the sensor head can only be replaced by the same type and ppm range (exact replacement) that match the configuration. If a different sensor head is installed, the GD unit will show a communication error.

As an alternative, calibration with gas can be performed via the service tool (or PC tool), calibration gas with correct concentration and the Danfoss calibration adapter. The Danfoss gas detection units have an integrated, digital calibration interface and procedure, which makes the calibration process easy, accurate, and time-saving. No potentiometers or multi-meters required for the calibration. The calibration procedure requires significantly less calibration gas per calibration compared to traditional routines.

Certificates, declarations and approvals

The list contains all certificates, declarations, and approvals for this product type. Individual code number may have some or all of these approvals, and certain local approvals may not appear on the list.

When you click on the link you will be directed to the latest version of the 'Declaration of Conformity'. Products developed and sold before this date of issue conform to the directives/standards in force at the time of their sale.

Approval type	Title	Certification body	Approval topic
Export Control Declaration	Gas detector	Danfoss	

Table: Conformity approvals

	EMC directives 2014/30/EU
	Conformity to EN 50271, EN 61010-1
	ETL listed to UL 61010-1 and CSA C22.2 No.61010-1
	Enables regulatory compliance with EN 378:2016, ISO 5149:2014, IAR 2-2017, and ASHRAE 15:2016

Contact details

Online support

Danfoss offers a wide range of support along with our products, including digital information, software, mobile apps and expert guidance. See the possibilities below.



The Danfoss Design center

Discover the Design Center, our advanced digital platform that streamlines product selection. With integrated tools and enhanced type pages, it's simpler than ever to access product information and documentation, and to select the right products. Check the availability of Danfoss products at partner locations and enjoy seamless transitions from selection to purchase with our basket-to-basket functionality. Whether you're buying from our distributors or directly from the Product Store, the Design Center simplifies your experience. Learn more at: designcenter.danfoss.com.



The Danfoss product store

The Danfoss Product Store is a one-stop shop available 24/7 for our customers, no matter where you are in the world or what area of industry you work in. Browse our catalog, check product details and documentation, view your prices and product availability, and quickly finalize your purchase. Start browsing at: store.danfoss.com.



Danfoss Partner Portal/Product Data tool

Designed to support you with easy access to product data extracts, essential resources, tools, and information. The Partner Portal provides a centralized hub for product documentation, training materials, marketing assets, and technical support, ensuring you have everything you need to succeed and grow your business with Danfoss. The Partner Portal is available 24/7 at: partner.danfoss.com and is ready to support your business.



Find technical documentation

Find technical documentation you need to get your project up running. Get direct access to our official collection of data sheets, certificates and declarations, manuals and guides, 3D models and drawings, case stories, brochures, and much more. Start searching now at: documentation.danfoss.com.



Danfoss Learning

Danfoss Learning is a free online learning platform. It features courses and materials specifically designed to help engineers, installers, service technicians, and wholesalers better understand the products, applications industry topics, and trends that will help you do your job better. Find your local Danfoss website here: learning.danfoss.com.



Get local information and support

Local Danfoss websites are the main sources for help and information about our company and products. Find product availability, get the latest regional news, or connect with a nearby expert - all in your own language. Find your local Danfoss website here: danfoss.com.

Danfoss A/S

Climate Solutions . danfoss.com . +45 7488 2222

Any information, including, but not limited to information on selection of product, its application or use, product design, weight, dimensions, capacity or any other technical data in product manuals, catalogues description, advertisements, etc. and whether made available in writing, orally, electronically, online or via download, shall be considered informative, and is only binding if and to the extent, explicit reference is made in a quotation or order confirmation. Danfoss cannot accept any responsibility for possible errors in catalogues, brochures, videos and other material. Danfoss reserves the right to alter its products without notice. This also applies to products ordered but not delivered provided that such alterations can be made without changes to form, fit or function of the products. All trademarks in this material are property of Danfoss A/S or Danfoss group companies. Danfoss and the Danfoss logo are trademarks of Danfoss A/S. All rights reserved.
