

iC7 Series Liquid-cooled LC Filter OF7Z1

1 Overview

1.1 LC Filter

The iC7 Series Liquid-cooled LC Filter OF7Z1 is designed to be used with iC7 Series Liquid-cooled System Modules. For more details, see the *iC7 Series Liquid-cooled System Modules Design Guide*.

The LC filter is used as an input filter with AFE or grid converter modules in applications where regenerative or low-harmonic functionality is required. The LC filter reduces switching noise, and ensures correct power quality and minimal interruption to the grid.

The filter complies with the standard IEC 61800-5-1 and must be used accordingly. The loadability of the filter must be equal to or higher than the rated operating current of the drive.

The LC filters are available in EMC categories C3 and C4. The protection rating of the LC filters is IP00.

Table 1: The Available LC Filters

Voltage rating	Current rating	Frame designation
380–500 V AC	460 A	LC10L
380–500 V AC	970 A	LC12L
525–690 V AC	380 A	LC10L
525–690 V AC	760 A	LC12L

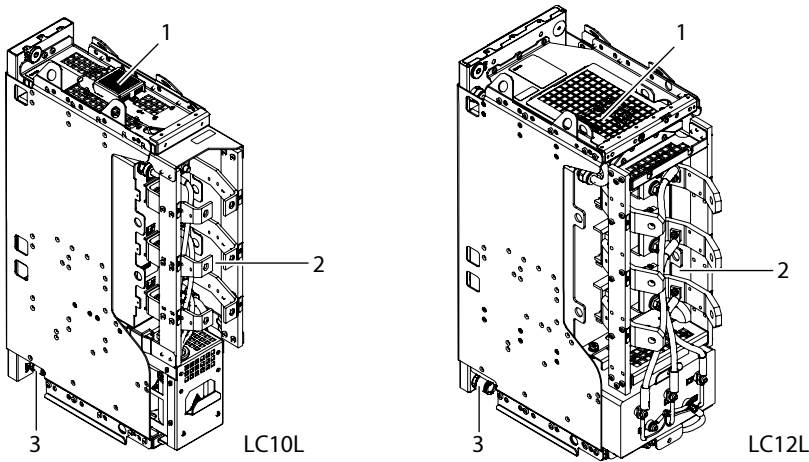

Figure 1: Liquid-cooled LC Filters

1	AuxBus temperature measurement board	2	Terminals
3	Cooling connectors		

1.2 Contents of the Delivery

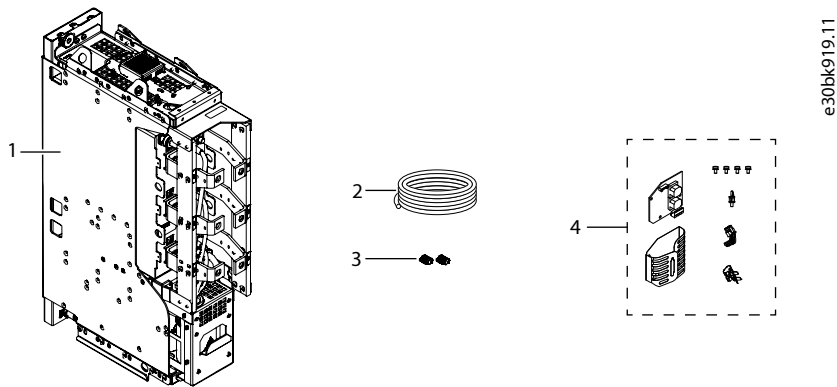

Figure 2: Items Included in the Delivery

1	LC Filter, LC10L or LC12L	2	AuxBus cable, 3 m (9.8 ft)
3	AuxBus terminals, 2 pcs	4	AuxBus isolation board installation kit
5	Accessories bag (not shown in the figure)		

Available options:

- +ANN1 = Push-in cooling connectors
- +ANNC = Threaded cooling connections, metric
- +AO20 = Coolant hose, 2 m (6.5 ft)

2 Mechanical Installation

2.1 Safety Information

WARNING	
	<p>SHOCK HAZARD FROM THE COMPONENTS</p> <p>The components of the drive are live when the drive is connected to mains.</p> <ul style="list-style-type: none"> • Do not make changes in the AC drive when it is connected to mains.

CAUTION	
	<p>BURN HAZARD</p> <p>The filter is hot during operation.</p> <ul style="list-style-type: none"> • Do not install the filter on a combustible surface. • Do not touch the filter when hot.

Only qualified personnel are allowed to perform the installation described in this guide.

Follow the instructions in this guide and relevant local regulations.

Also read the instructions and safety information in the *iC7 Series Air-cooled and Liquid-cooled System Modules and Air-cooled Enclosed Drives Installation Safety Guide*.

2.2 Installation Requirements

The products described in this guide have the protection rating IP00/UL Open Type. Install the products in an enclosure that has a correct level of protection against the ambient conditions in the installation area. Make sure that the enclosure gives protection against water, humidity, dust, and other contaminations.

The enclosure must also be sufficiently strong for the weight of the filter components and other devices.

The protection rating of the enclosure must be at least IP21/UL Type 1. When preparing the installation, obey the local regulations.

2.3 Installing the Filter into a Cabinet

Procedure

1. Install the filter into the cabinet in a vertical or horizontal position.

See [2.4 Dimensions of the LC Filter](#).

2. Attach the filter from the mounting holes on the frame to the cabinet.

For aluminum parts, use M6 grade 8.8 screws with a thread depth of 6–14 mm (0.24–0.55 in), and a tightening torque of 6–8 Nm (53–71 in-lb).

For sheet metal parts, use M5 (DIN 7500) screws with a maximum thread depth of 20 mm (0.79 in), and a tightening torque of 3–4 Nm (27–35 in-lb).

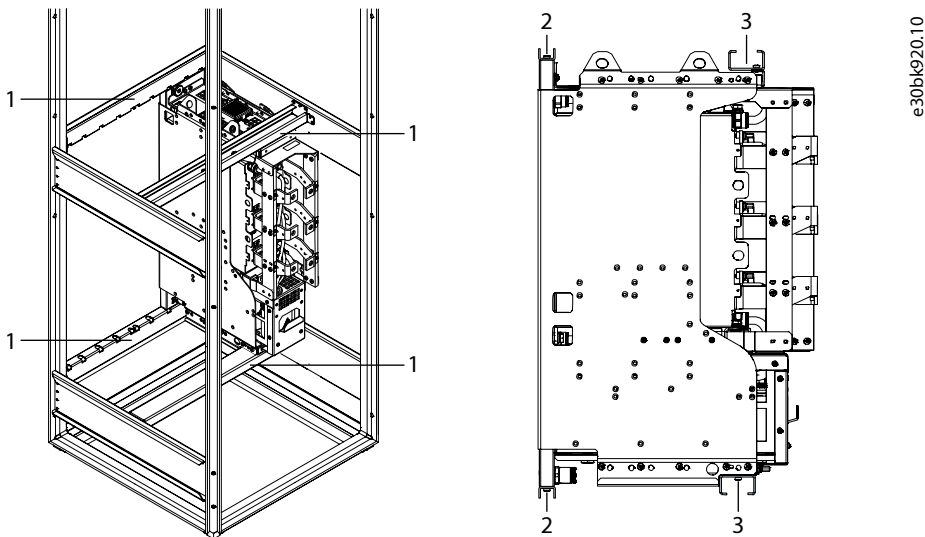

Figure 3: Example of Mounting the LC Filter in the Cabinet Vertically

- | | | | |
|---|-------------------------------------|---|----------------------------------|
| 1 | Mounting brackets | 2 | Mounting holes in aluminum parts |
| 3 | Mounting holes in sheet metal parts | | |

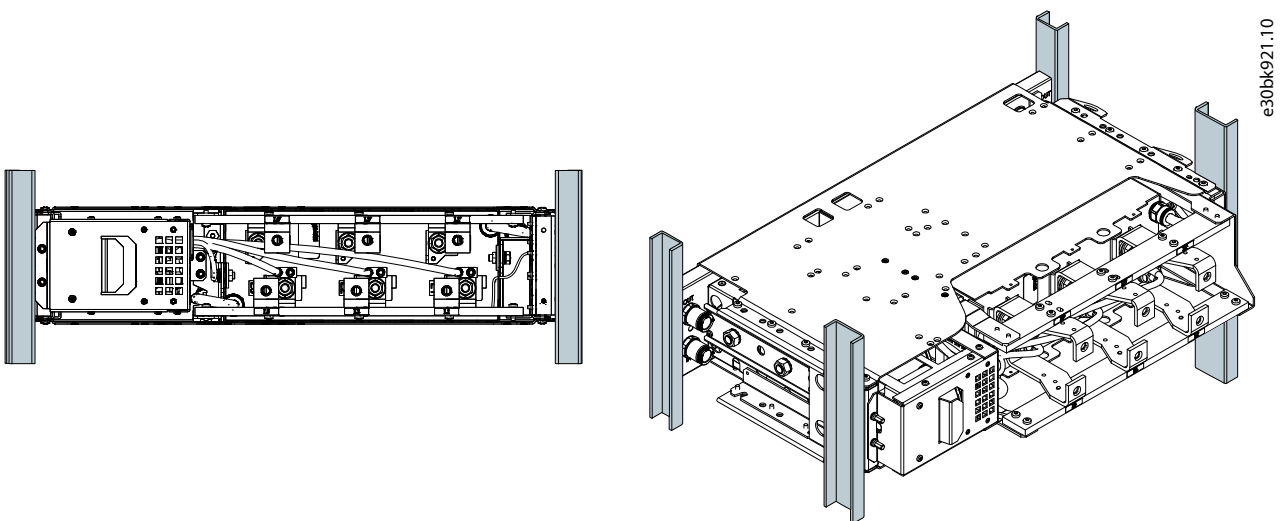

Figure 4: Example of Mounting the LC Filter Horizontally

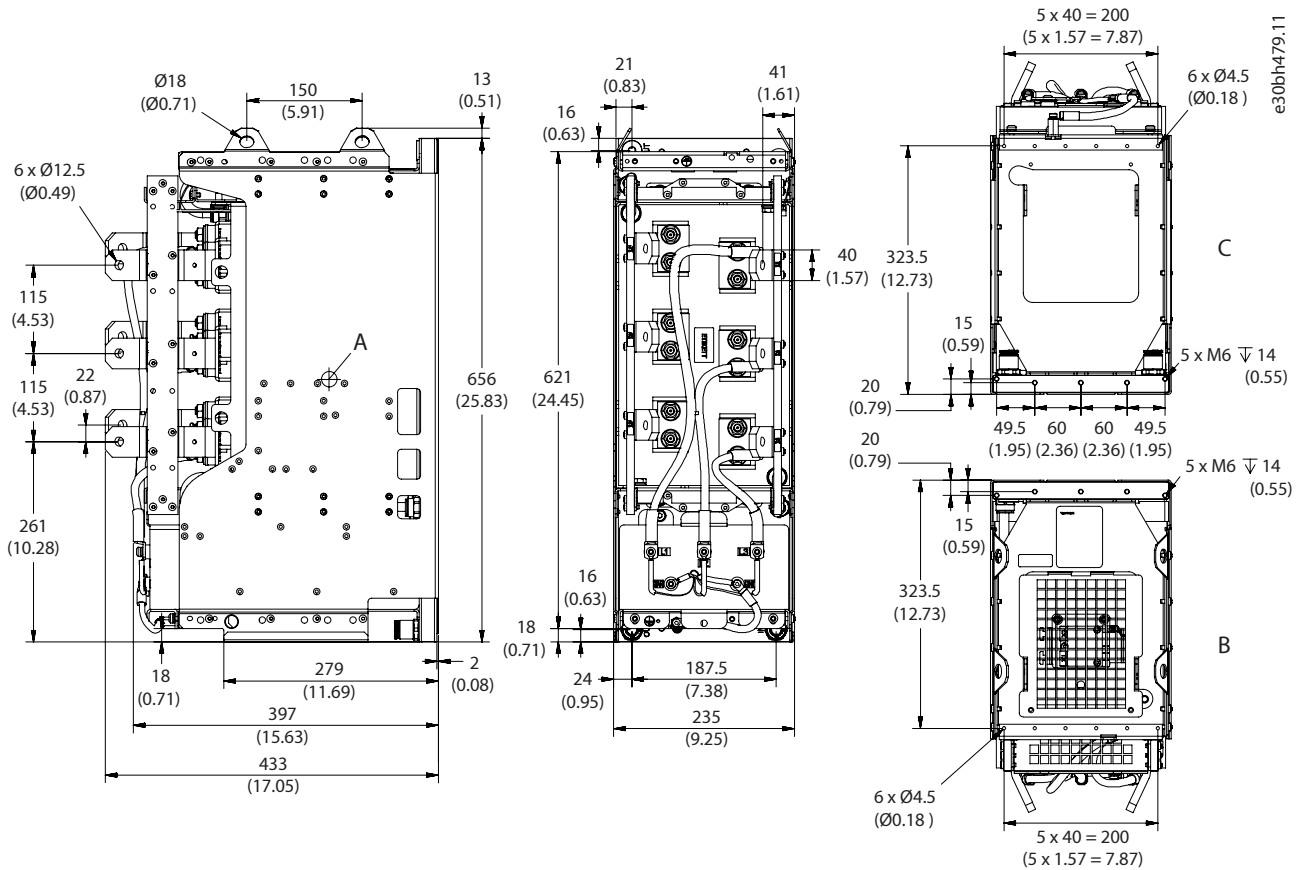

Figure 6: Dimensions of the LC Filter Size 12, in mm (in)

3 Cooling Requirements

3.1 Safety in Liquid-cooling

WARNING

POISONOUS COOLANTS

Glycols and inhibitors are poisonous. If touched or consumed, they can cause injury.

- Prevent the coolant from getting into the eyes. Do not drink the coolant.

CAUTION



HOT COOLANT

Hot coolant can cause burns.

- Avoid contact with the hot coolant.

CAUTION

PRESSURIZED COOLING SYSTEM

Sudden release of pressure from the cooling system can cause injury.

- Be careful when operating the cooling system.

NOTICE

INSUFFICIENT COOLING CAPACITY

Insufficient cooling can cause the product to become too hot and thus become damaged.

- To make sure that the cooling capacity of the cooling system stays sufficient, make sure that the cooling system is vented and that the coolant circulates properly even before applying mains power.

NOTICE

DAMAGE TO COOLING SYSTEM

If the coolant circulation is stopped too soon, high-temperature components can cause rapid local increase in the coolant temperature, which can damage the cooling system.

- Do not stop the cooling system when stopping the drive. Keep the coolant circulation flowing for 2 minutes after the drive has been stopped.

3.2 General Information on Cooling

NOTICE

For more detailed information about the requirements for liquid-cooling, see the *iC7 Series Liquid-cooled System Modules Design Guide*.

The product is cooled with liquid. The liquid circulation of the drive is usually connected to a heat exchanger (liquid-to-liquid or liquid-to-air) that cools down the liquid circulating in the cooling elements. The cooling elements are made of aluminum.

Although the product is liquid-cooled, there are some heat losses to the air. When the filter is installed in an enclosure, some air cooling is required. For more information about the air-cooling requirements, see the *iC7 Series Liquid-cooled System Modules Design Guide*.

If there is no risk of freezing, purified water can be used as coolant. Freezing water permanently damages the cooling system. Purified water is demineralized, deionized, or distilled water.

The allowed antifreeze coolants are the following ethylene glycols and propylene glycols.

- **Ethylene glycols:** DOWCAL 100 or Clariant Antifrogen N
- **Propylene glycols:** DOWCAL 200 or Clariant Antifrogen L

These glycols already include corrosion inhibitors. Do not add any other inhibitor. Do not mix different glycol qualities because there can be harmful chemical interactions.

The glycol concentration of the coolant must be 25–55% by volume, according to the specified ambient temperature. Higher concentration reduces cooling capacity. Lower concentration results in biological growth and inadequate amount of corrosion inhibitors. Antifreeze must be mixed with purified water.

To gain full performance of the product, the temperature of the coolant entering the system module must be a maximum of 45 °C (113 °F). Typically, 95% of the power losses are dissipated in the coolant. It is recommended to equip the cooling circulation with temperature supervision.

Table 2: Flow Rate in the Filter with Water

Frame designation	Minimum flow rate [l/min]	Nominal flow rate (45 °C) [l/min]	Liquid volume per element [l]
LC10L	5.5	8.0	0.70
LC12L	8.0	11.0	1.25

Table 3: Correction Factors when Using a Water-glycol Mixture

Mixture	Correction factor
30% water-glycol mixture	1.18
50% water-glycol mixture	1.3

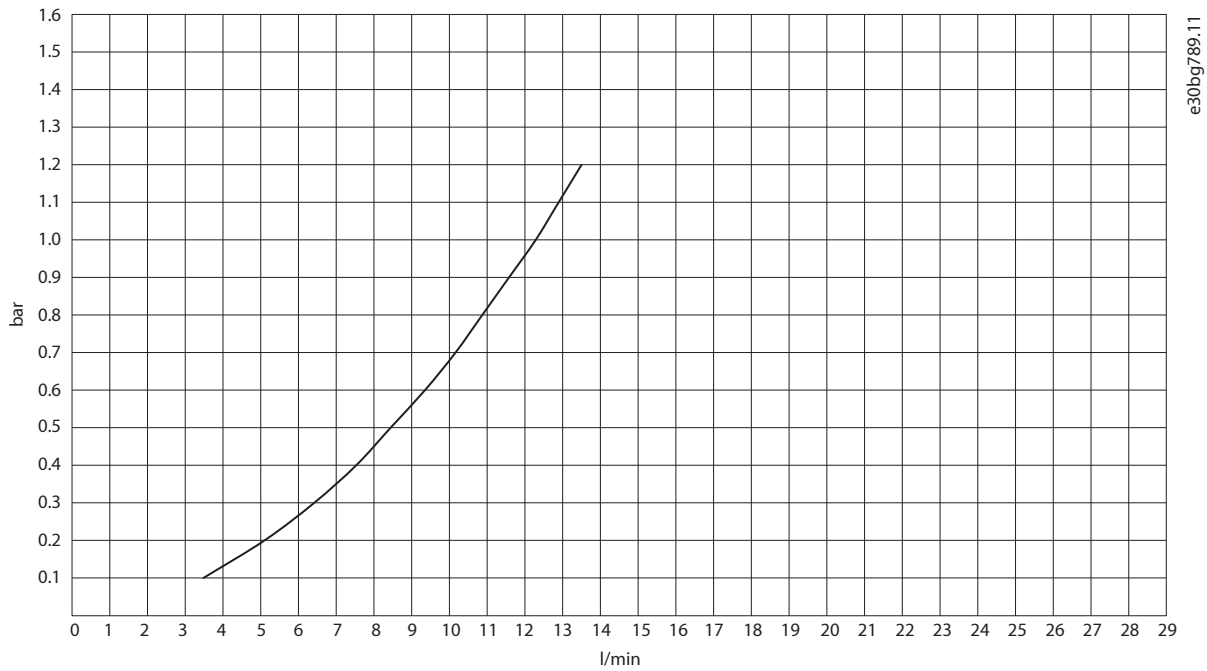

Figure 7: Pressure Drop with Water, LC10L

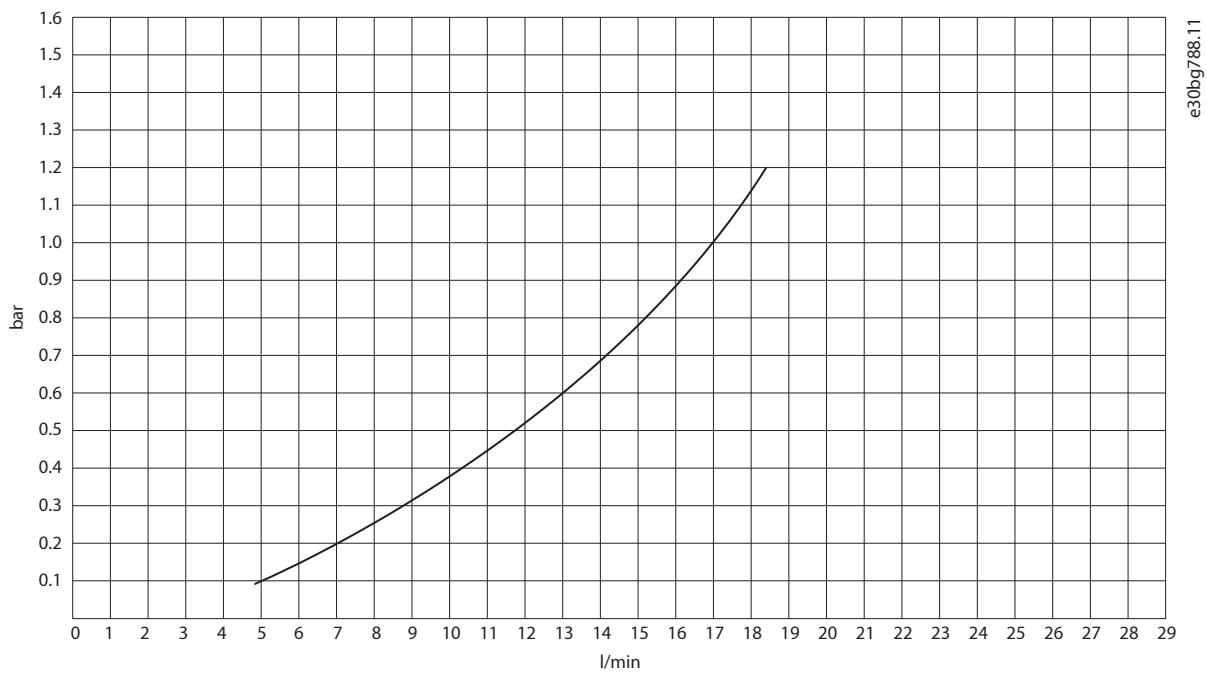

Figure 8: Pressure Drop with Water, LC12L

3.3 Cooling Circuit Connectors

The LC filter has cooling circuit connectors in the manifold plate. The internal thread size is G1/2. The depth of the threads is 13 mm (0.51 in). The maximum tightening torque is 30 Nm (265 in-lb). Push-in connectors are available as option +ANN1.

The inlet and outlet connectors are at the bottom of the filter. An alternative outlet connector is available at the top of the filter.

If the optional outlet connector at the top is used, the outlet connector at the bottom must be closed with a plug.

Do not connect filters in series. Connecting in series requires high flow rates and high pressure because of the temperature rise of the coolant in the filters.

Table 4: Recommended Connectors

Connector	Tightening torque	Pipe	Pipe ferrule
Parker 69111621 MALE STUD 1/2"BSPP SS STEEL 31 6L D16 EPDM SEAL	20–30 Nm (177–265 in-lb)	PA 16/13 pipe	Parker 1827-16-13

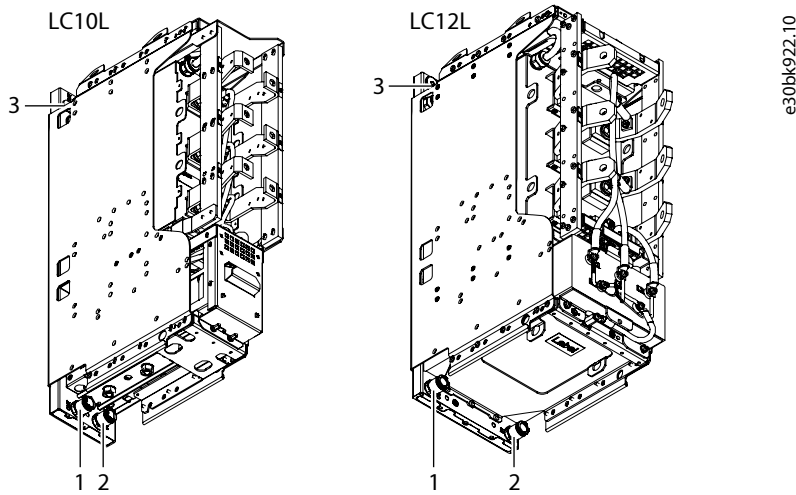

Figure 9: Location of the Cooling Circuit Connectors

1	Outlet connector	2	Inlet connector
3	Alternative outlet connector		

4 Electrical Installation

4.1 Electrical Installation Safety

⚠ WARNING



OVERHEATED CABLES

Overheated cables are a fire hazard.

- Because of several possible cable installations and environmental conditions, it is important to consider local regulations and IEC/EN standards.

Route the wires away from sharp edges, screw threads, burrs, fins, moving parts, drawers, and similar parts, which can abrade the wire insulation.

For the main circuit, use double insulated wires or protect the wires with, for example, a protective sleeve or wrap to minimize the risk of short circuit. Maintain separation between the main and control circuit wires.

4.2 Installing the LC Filter

Install the LC Filter between the AFE and the AC grid. If the AFE has parallel power units, install a separate LC Filter for each of them. See [4.11 Wiring Diagrams](#).

4.3 Cable Requirements

Keep the cable length between the filter and the system module as short as possible. The recommended maximum cable length is 3 m (9.8 ft). For information about recommended cable types and required cable sizes, see the *iC7 Series Liquid-cooled System Modules Design Guide*.

4.4 Grounding

Ground the filter in accordance with applicable standards and directives.

Unless local wiring regulations state otherwise, the cross-sectional area of the protective grounding conductor must be at least 50% of the cross-sectional area of the phase conductor and made of the same material when the phase conductor cross-section is above 35 mm² (AWG 2) according to IEC 60364-5-54; 543.1.

The connection must be fixed.

Use the marked grounding terminals on the frame of the filter. To achieve the required cross-sectional area for the protective grounding connection, also the mounting holes on the filter frame can be used if necessary.

For more detailed information about grounding, see the *iC7 Series Liquid-cooled System Modules Design Guide*.

4.5 AC Fuses

The front-end modules in the drive system must be equipped with fast-acting AC fuses to limit the damage of the drive system. Install the AC fuses at the input side of the LC Filter.

The AC fuses are not included in the LC Filter delivery. For the recommended fuse types and required fuse sizes, see the *iC7 Series Liquid-cooled System Modules Design Guide*.

4.6 Installing the Cables

1. Connect the mains AC cables to terminals L1, L2, and L3.

The terminals are not designed for installing the mains cabling directly. Install additional terminals for the recommended mains AC cabling. Use internal cabling or busbars between the AC terminals of the LC Filter and the actual mains terminals. Define the size of the internal cables or busbars according to the nominal current and according to local regulations.

- LC10L: Use M10 screws and tightening torque 35–40 Nm (310–354 in-lb).
- LC12L: Use M12 screws and tightening torque 55–70 Nm (487–620 in-lb).

2. Connect the AC cables from the AFE to terminals L1', L2', and L3'.

- LC10L: Use M10 screws and tightening torque 35–40 Nm (310–354 in-lb).
- LC12L: Use M12 screws and tightening torque 55–70 Nm (487–620 in-lb).

3. Check that the ground capacitor of the LC filter is connected to the ground.

For more information about ground capacitor connections and installation in an IT grid, see the *iC7 Series Liquid-cooled System Modules Design Guide*.

4. Connect the PE terminal to the ground.

Use M8 screws and tightening torque 17–20 Nm (150–177 in-lb).

4.7 Terminals

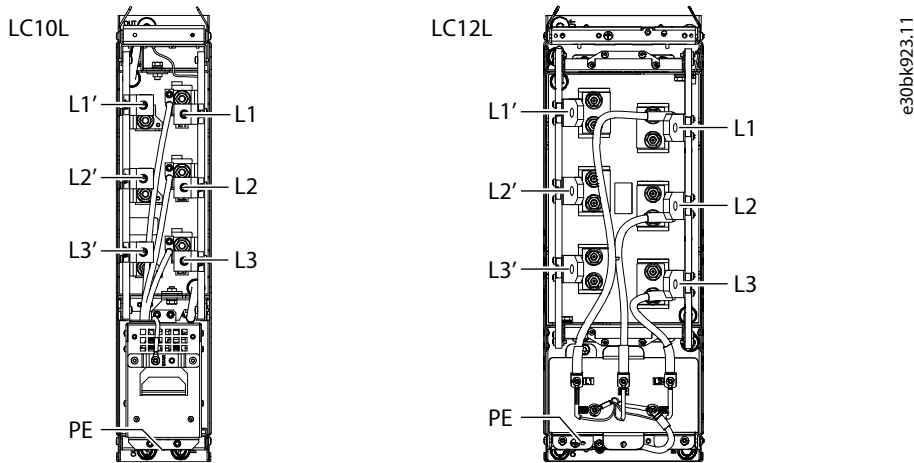

Figure 10: Terminals of the LC Filter

Table 5: LC Filter Terminal Descriptions

Terminal	Description
L1 L2 L3	AC connection point for mains input
L1' L2' L3'	AC connection point for output to AFE
PE	Grounding terminal for filter frame

4.8 Installing the AuxBus Isolation Board

Install the AuxBus isolation board on the system module.

1. Release the cover of the AuxBus isolation board. Remove the M4x8 combi screw with a TX20 bit.

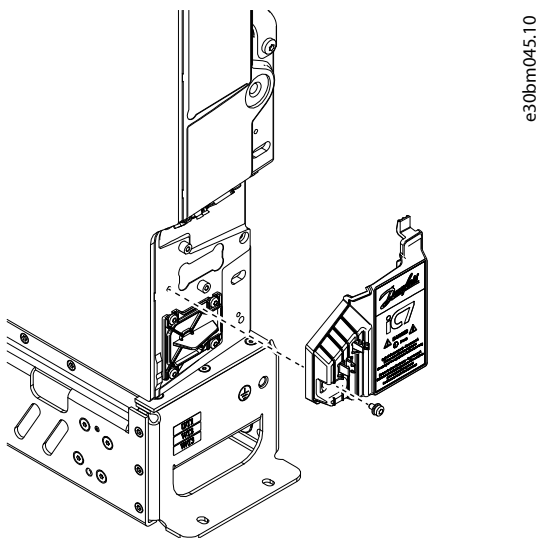
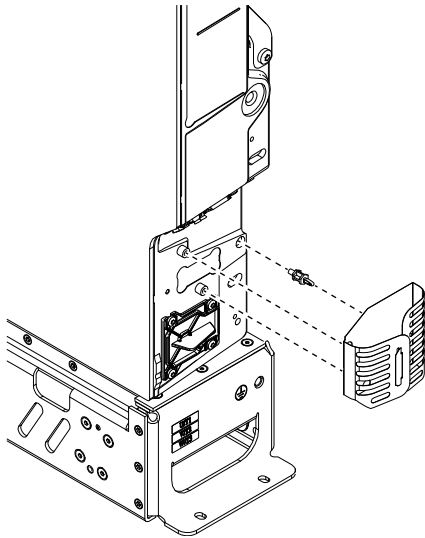

Figure 11: Removing the Cover of the AuxBus Isolation Board

2. Install the PCB insulator.
 - a. Mount the spacer screw on the front of the module. Use an 8 mm hex bit and tighten the screw to torque 0.4 Nm (3.5 in-lb).
 - b. Mount the PCB insulator on the spacer screw.



e30bm046.10

Figure 12: Installing the PCB Insulator

3. Mount the AuxBus isolation board with 2 size M4x8 combi screws. Use a TX20 bit and tighten the screws to torque 2.2 Nm (19.5 in-lb).

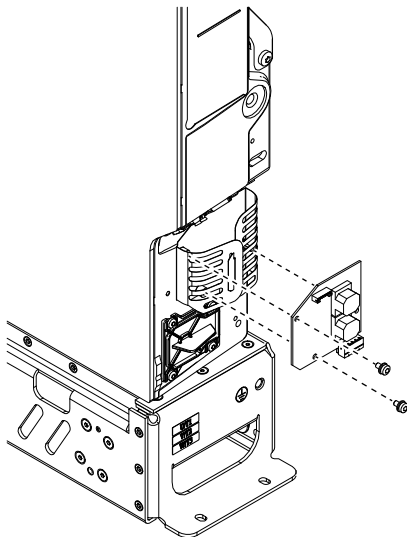

e30bm047.10

Figure 13: Mounting the AuxBus Isolation Board

4. Connect the AuxBus wire harness to terminal X78 on the AuxBus isolation board and to terminal X77 on the system module.

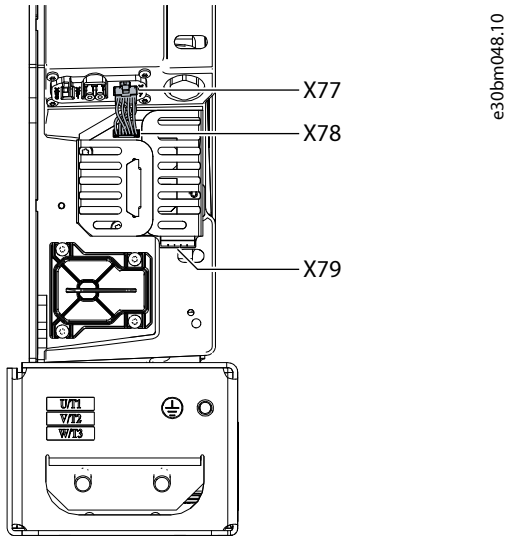

Figure 14: AuxBus Wire Harness Connection

5. Mount the relief plate with a M4x8 screw. Use a TX20 bit and tighten the screw to torque 2.2 Nm (19.5 in-lb).

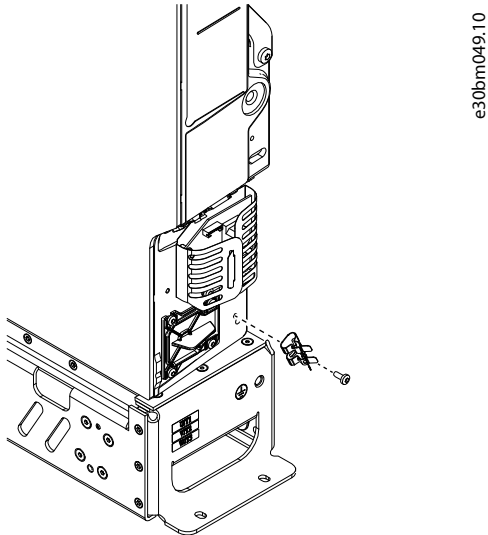

Figure 15: Mounting the Relief Plate

6. Reinstall the cover of the AuxBus isolation board. Use the old M4x8 combi screw or the spare one provided in the delivery. Use a TX20 bit and tighten the screw to torque 2.2 Nm (19.5 in-lb).

4.9 Preparing the AuxBus Cable

1. Cut the cable to the required length.
2. To reveal the wires, strip the cable at both ends.
3. At 1 end of the cable, remove approximately 15 mm (0.59 in) of the cable insulation.
4. Strip the wires 7 mm (0.28 in).
5. Connect the wires to the terminals included in the delivery. Use the tightening torque 0.22–0.25 Nm (1.9–2.2 in-lb).

Table 6: Wiring of the AuxBus Terminals

Pin	Wire color	Signal
1	White	+24 V
2	Brown	GND
3	Green	CAN_H

Table 6: Wiring of the AuxBus Terminals - (continued)

Pin	Wire color	Signal
4	Yellow	CAN_L
5	Grey	+24 V

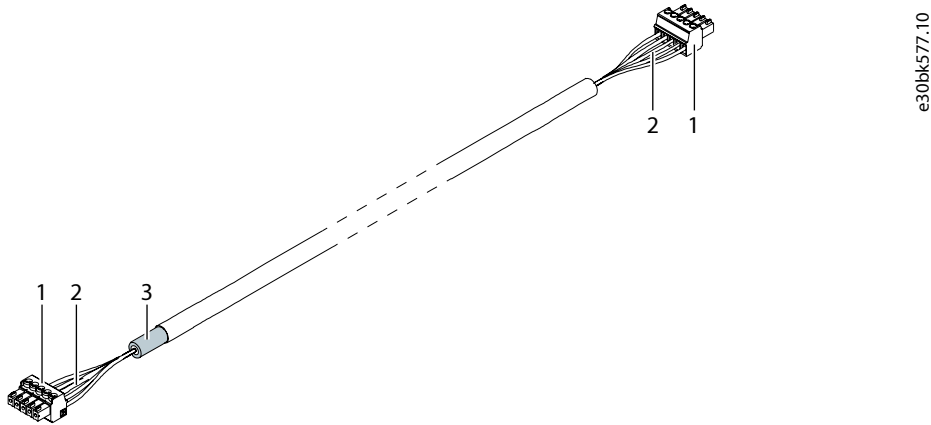

Figure 16: The Ready AuxBus Cable

- | | | | |
|---|----------------|---|-------|
| 1 | Terminals | 2 | Wires |
| 3 | Shield removed | | |

4.10 AuxBus Connections

NOTICE

For the drive to be able to protect the filters, AuxBus must be connected.

For more information about AuxBus, see the *iC7 Series Liquid-cooled System Modules Design Guide*.

1. Locate the AuxBus temperature measurement board at the top of the filter.

To access the AuxBus temperature measurement board in LC12L, remove the cover.

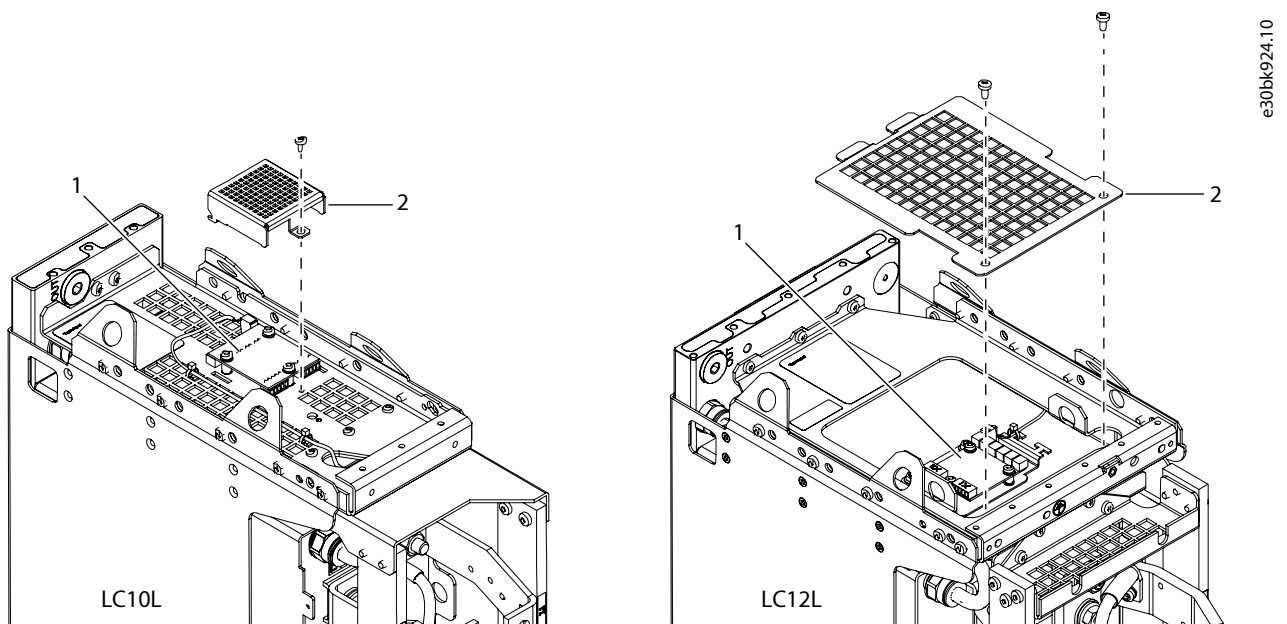

Figure 17: Accessing the AuxBus Temperature Measurement Board

- 1 AuxBus temperature measurement board
- 2 Cover

2. Connect the AuxBus cable between the filter and the power unit. If there are several power units and filters, connect each filter to the power units individually.
 - a. Connect the end of the AuxBus cable where the insulation was removed to terminal X79 on the power unit.
 - b. Connect the other end of the AuxBus cable to terminal X86 on the AuxBus temperature measurement board.

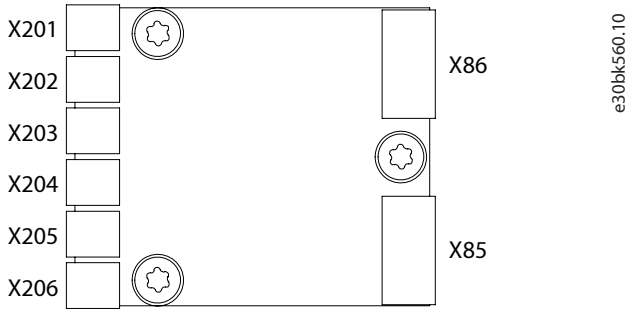

Figure 18: Terminals on the AuxBus Temperature Measurement Board

X206	Temperature measurement input	X85	AuxBus in
X86	AuxBus out		

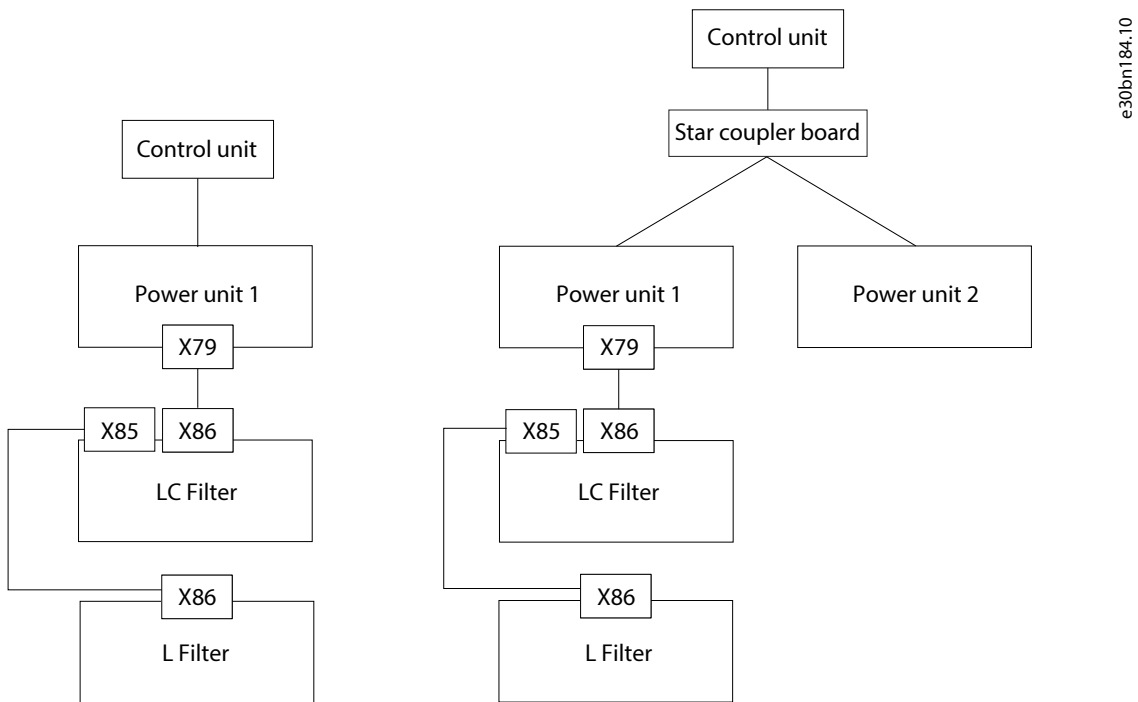
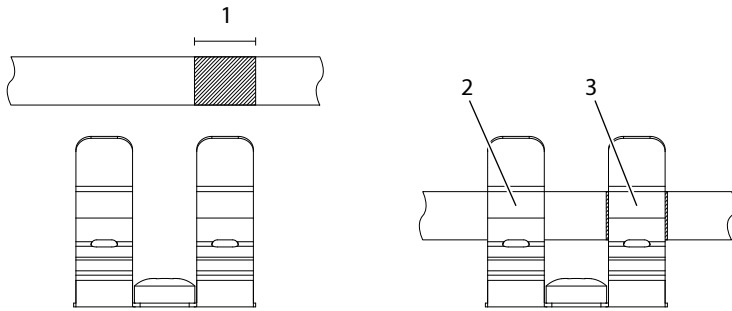

Figure 19: AuxBus Topology

3. Route the cable so that there is no risk of getting in touch with bare busbars or terminals.
4. Ground each AuxBus cable at 1 end at the X79 terminal. To make the grounding connection, attach the shield of the cable to the frame with a cable clamp.

If an L filter is installed, ground also its AuxBus cable at 1 end at the X85 terminal.

The lower part of the cable clamp fixes the cable to the plate and provides strain relief. The upper part provides ~360° grounding for the cable shield.



e30bj147.11

Figure 20: Using the Cable Clamps

1	Stripping length, 15 mm (0.59 in)	2	Strain relief
3	Grounding		

- At the terminal X86 end of the cable, place the cable in a cable clamp for strain relief.

4.11 Wiring Diagrams

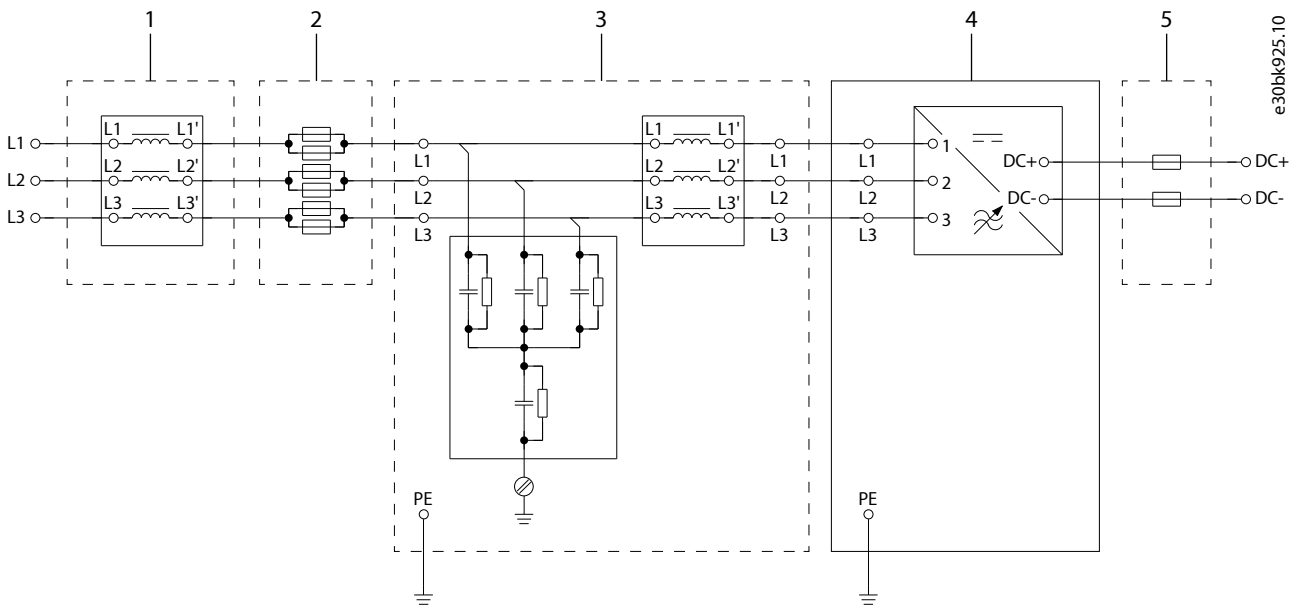

e30bk925.10

Figure 21: Wiring Diagram, LC10L

1	L Filter (not included in the delivery)	2	AC fuses (not included in the delivery)
3	LC Filter	4	AFE module AM10L (not included in the delivery)
5	DC fuses (not included in the delivery)		

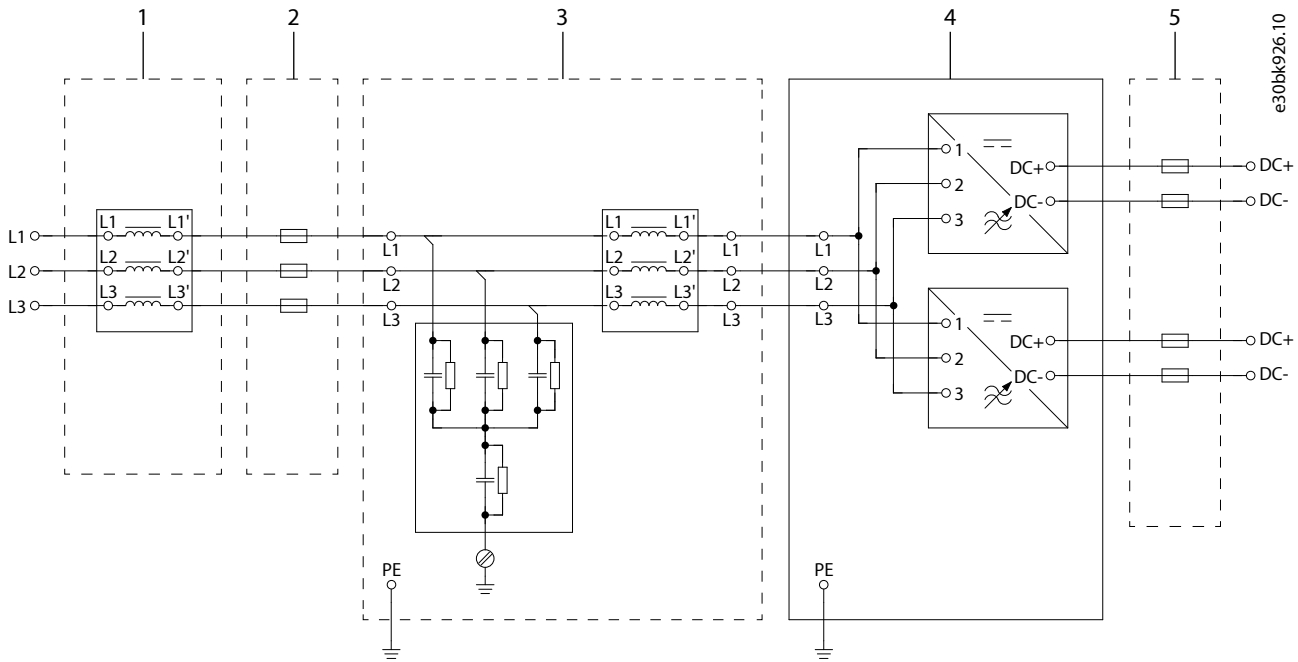

Figure 22: Wiring Diagram, LC12L

1	L Filter (not included in the delivery)	2	AC fuses (not included in the delivery)
3	LC Filter	4	AFE module AM12L (not included in the delivery)
5	DC fuses (not included in the delivery)		

5 Maintenance

5.1 Preventive Maintenance Recommendations

Generally, all technical equipment needs a minimum level of preventive maintenance. Regular maintenance is recommended to ensure trouble-free operation and long life of the product. It is also recommended, as a good service practice, to record a maintenance log with counter values, date, and time describing the maintenance and service actions.

Danfoss recommends the following inspections and service intervals for the product.

NOTICE

The service schedule for part replacements can vary depending on operating conditions. Under specific conditions, the combination of stressful operation and environmental conditions work together to reduce the lifetime of the components significantly. These conditions can include, for example, extreme temperature, dust, high humidity, hours of use, corrosive environment, and loading.

For operation in stressful conditions, Danfoss offers the DrivePro® Preventive Maintenance service. DrivePro® services extend the lifetime and increase the performance of the product with scheduled maintenance including customized part replacements. DrivePro® services are tailored to your application and operating conditions.

Table 7: Maintenance Schedule for Liquid-cooled Filters

Component	Inspection interval ⁽¹⁾	Service schedule ⁽²⁾	Preventive maintenance actions
Installation			
Visual inspection	1 year	–	Check for the unusual, for example, for signs of overheating, aging, corrosion, and for dusty and damaged components.

Table 7: Maintenance Schedule for Liquid-cooled Filters - (continued)

Component	Inspection interval ⁽¹⁾	Service schedule ⁽²⁾	Preventive maintenance actions
Cable routing	1 year	–	Check for parallel routing of motor cables, mains wiring, and signal wiring. Avoid parallel routing. Avoid routing cables through free air without support. Check for aging and wearing of the cable insulation.
Power cabling	1 year	–	Check for loose connections, aging, insulation condition, and proper torque to the drive connections. Check for proper rating of fuses and continuity check. Observe if there are any signs of operation in a demanding environment. For example, discoloration of the fuse housing can be a sign of condensation or high temperatures.
Control wiring	1 year	–	Check for tightness, damaged or crimped wires, or ribbon wires. Terminate the connections correctly with solid crimped ends. The use of shielded cables and grounded EMC plate, or a twisted pair is recommended.
EMC consideration	1 year	–	Inspect the installation wiring regarding the electromagnetic capability and the separation distance between control wiring and power cables.
Grounding	1 year	–	The drive system requires a dedicated ground wire connecting the drive, the output filter, and the motor to the building ground. Check that the ground connections are tight and free of paint or oxidation. Daisy-chain connections are not allowed. If applicable, braided straps are recommended.
Proper clearances	1 year	–	Check that the required external clearances for proper airflow for cooling are followed according to the type of the drive. For clearances, refer to the local design regulations.
Corrosive environments	1 year	–	Conductive dust and aggressive gases, such as sulphide, chloride, and salt mist, can damage the electrical and mechanical components. Air filters do not remove airborne corrosive chemicals. Act based on findings.
Filter components			
Capacitors	1 year	12–15 years	The expected life time of the capacitor is determined based on load and the temperature of the environment. Replace parts according to the service schedule. For applications with heavy loads or demanding environments, replace the capacitors every 12 years. In a typical environment, within the specifications of the filter, replace every 15 years. Only trained service personnel are allowed to perform this action.
PCB	1 year	10–12 years	Visually inspect the printed circuit boards for signs of damage or degrading due to aging, corrosive environments, dust, or environments with high temperatures. Only trained service personnel are allowed to perform the inspection and service action.
Insulators	1 year	10–15 years	Inspect the insulators for signs of degradation due to high temperature and aging. Replacement is based on findings. Only trained service personnel are allowed to perform this action.
Coolant			

Table 7: Maintenance Schedule for Liquid-cooled Filters - (continued)

Component	Inspection interval ⁽¹⁾	Service schedule ⁽²⁾	Preventive maintenance actions
Log	Commissioning/start up, or at time of replacing liquid coolant	–	Record the water quality specification values to create a baseline for future reference before and after adding inhibitor and glycol. Also record the system pressure, coolant flow rate, temperature range, and create a baseline for future reference.
Glycols	1 year	Based on findings	Measure and record the level of glycol in the cooling system. The minimum concentration level is always 75/25% demineralized water/glycol.
Corrosive inhibitors	1 year	Based on findings	Measure and record the level of corrosive inhibitor (Cortec-VpCI-649) in the liquid coolant (see specification). Measure the level of the inhibitor every year. If the inhibitor level is below the recommended level of 1%, add more inhibitor. Before adding more inhibitor, practice caution not to exceed the level of electrical conductivity. Use the corrosive inhibitor recommended by Danfoss.
Pre-mixed glycol and inhibitor coolant	1 year	Based on findings	The pre-mixed coolants contain specific percentages of glycol and inhibitor for antifreeze and corrosion protection. The advantage of using a pre-mixed coolant is that the chemical composition is within Danfoss specifications, and there is no need for analyzing the coolant.
Demineralized water	1 year	Based on findings	Only use demineralized or deionized water in the coolant solution. Record and compare the chemical composition values when replacing or adding coolant.
Liquid cooling system			
Pipes, hoses, and connections	1 year	1 year	Check for external signs of moisture, corrosion, and coolant leaks. Check the tightness of the cooling pipe connections. Check the heat sinks and host pipes in the cooling system.
Leak detector	1 year	10 years	Test the functioning of the leak detector.
Power unit heat sinks	1 year	6 years	Check that the heat sink temperature across all cooling circuits or power phases is balanced. Imbalanced temperature of the cooling circuits is a possible sign of a restriction. Under normal conditions, clean or acid-wash the heat sinks every 6 years with cleaning products recommended by Danfoss. Refill the coolant system and log the new coolant specification values.
Auxiliary equipment	1 year	According to manufacturer recommendations	Check that the sensors, gauges, and indicators are functioning correctly. Act based on findings.
System cooling capacity	1 year	Based on findings	Test the cooling capacity and the thermal transfer of the system. Record the coolant system flow, pressure, and input and output temperature, and compare to the previous measurements. Act based on findings.

1) Defined as the time after the commissioning/startup or the time from the previous inspection.

2) Defined as the time after the commissioning/startup or the time from the previous service schedule actions.

5.2 Recommended Disposal

When the product reaches the end of its service life, its primary components can be recycled.

Before the materials can be removed, the product must be disassembled. Product parts and materials can be dismantled and separated. Generally, all metals, such as steel, aluminum, copper and its alloys, and precious metals can be recycled as material. Plastics, rubber, and cardboard can be used in energy recovery. Printed circuit boards and large electrolytic capacitors with a diameter of over 2.5 cm (1 in) need further treatment according to IEC 62635 guidelines. To ease recycling, plastic parts are marked with an appropriate identification code.

Contact the local Danfoss office for further information on environmental aspects and recycling instructions for professional recyclers. End-of-life treatment must follow international and local regulations.

All products are designed and manufactured in accordance with Danfoss company guidelines on prohibited and restricted substances. A list of these substances is available at www.danfoss.com.



This symbol on the product indicates that it must not be disposed of as household waste. Do not dispose of equipment containing electrical components together with domestic waste.

It must be handed over to the applicable take-back scheme for the recycling of electrical and electronic equipment.

- Dispose of the product through channels provided for this purpose.
 - Comply with all local and currently applicable laws and regulations.
-

Danfoss Drives Oy
Runsorintie 7
FIN-65380 Vaasa
drives.danfoss.com



.....
Any information, including, but not limited to information on selection of product, its application or use, product design, weight, dimensions, capacity or any other technical data in product manuals, catalog descriptions, advertisements, etc. and whether made available in writing, orally, electronically, online or via download, shall be considered informative, and is only binding if and to the extent, explicit reference is made in a quotation or order confirmation. Danfoss cannot accept any responsibility for possible errors in catalogs, brochures, videos and other material. Danfoss reserves the right to alter its products without notice. This also applies to products ordered but not delivered provided that such alterations can be made without changes to form, fit or function of the product. All trademarks in this material are property of Danfoss A/S or Danfoss group companies. Danfoss and the Danfoss logo are trademarks of Danfoss A/S. All rights reserved.
.....

