

Instruction

# APP pumps

APP 21 - 38 with Ceramics

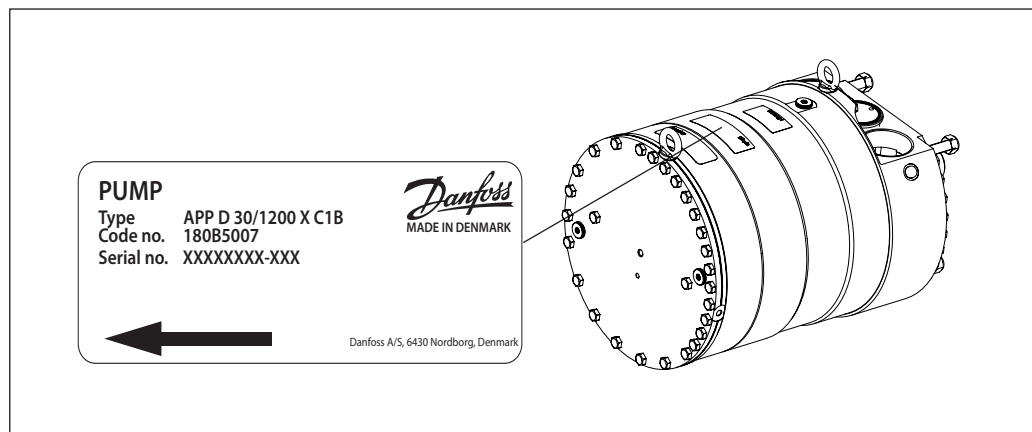

Table of Contents

Table of Contents

- 1. Identification .....2
- 2. System design .....3
  - 2.1 Open-ended systems with direct water supply.....3
  - 2.2 Preferred RO system design and P&ID .....3
  - 2.3 Reversible pumps .....4
  - 2.4 General comments.....4
- 3. Building up the pump unit .....4
  - 3.1 Mounting .....4
  - 3.2 Direction of rotation .....5
  - 3.3 Orientation .....5
  - 3.4 Protection from too high pressures.....5
  - 3.5 Grounding .....5
  - 3.6 Connections .....6
- 4. Initial start-up.....7
- 5. Operation.....7
  - 5.1 Temperature.....7
  - 5.2 Pressure .....8
  - 5.3 Dry running.....8
  - 5.4 Disconnection .....8
  - 5.5 Storage .....8
- 6. Service.....8
  - 6.1 Warranty.....8
  - 6.2 Maintenance.....8
  - 6.3 Repair .....8

1. Identification



2. System design

The design of the system must ensure that self-emptying of the pump during standstill is avoided.

The inlet pressure of the pump must never exceed the outlet pressure. This may typically occur in boosted or open-ended systems with direct water supply.

2.1 Open-ended systems with direct water supply

The pump is supplied with water directly from a feed pump.

The inlet pressure must be within the limits describes in the datasheet for the specific pump.

To protect the pump from being damaged by peaks of high-pressure in case the pump stops momentarily, it is required to mount a low-pressure relief valve on the inlet line.

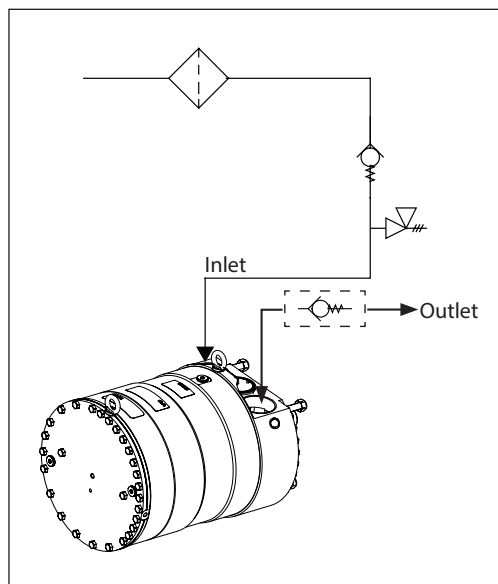

2.2 Preferred RO system design and P&ID

1. Dimension the inlet line to obtain minimum pressure loss (large flow, minimum pipe length, minimum number of bends/connections, and fittings with small pressure losses).
2. Place an inlet filter (1) in front of the APP pump (2). Please consult Danfoss filter data sheet for guidance on how to select the right filter. Thoroughly clean pipes and flush system prior to start-up.
3. Place a monitoring pressure switch (3) set at min. inlet pressure between filter and pump inlet. The monitoring switch must stop the pump at pressures lower than minimum pressure.
4. Use flexible hoses (4) to minimize vibrations and noise.
5. In order to eliminate the risk of damage and cavitation, a positive pressure at the inlet (5) is always to be maintained at min. inlet pressure and max. inlet pressure.

It is recommend to install safety valve or a pressure relief valve (9) in order to avoid high-pressure peaks in case the pump stops momentarily or is spinning back-wards.

6. For easy system bleeding and flushing, a bypass non-return valve (6) is integrated in the APP pump.
7. A non-return valve (7) in outlet can be installed in order to avoid backspin of the pump. The volume of water in the membrane vessel works as an accumulator and will send flow backwards in case of the pump stops momentarily.
8. A safety valve or a pressure relief valve (8) can be installed in order to avoid system damage as the Danfoss APP pump creates pressure and flow immediately after start-up, regardless of any counter pressure.

**Note: If a non-return valve is mounted in the inlet line, a low-pressure relief valve is also required between non-return valve and pump as protection against high-pressure peaks.**

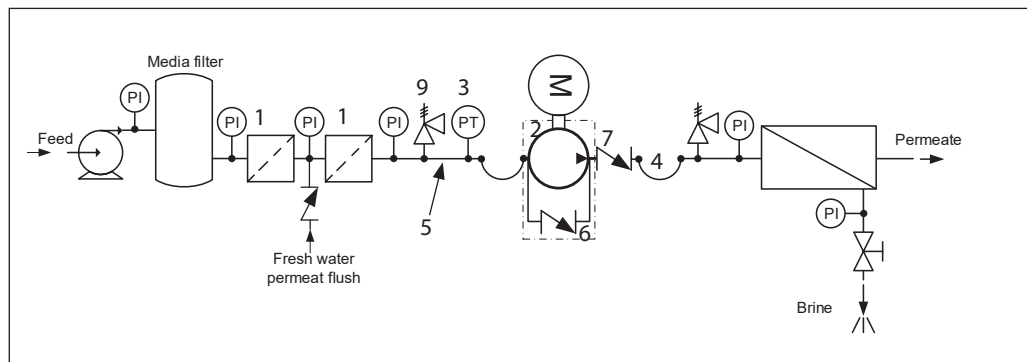

**2.3 Reversible pumps**

If exposed to high-pressure in the outlet while the electric motor is not energized, the pumps will start spinning backwards. This will not harm the pumps as long as the pressure in the inlet does not exceed the max. pressure peak of 10 barg(145 psig).

If a non-return valve is mounted in the inlet line, a low-pressure relief valve is also required as protection against high-pressure pulses and high-pressure in general.

Alternatively a high-pressure check valve can be mounted in the pump discharge line to prevent the pump from reversing.

The dotted setup ensures that the inlet pressure does not exceed 10 barg (145 psig), when a non-return valve is mounted in the inlet.

In order to avoid the risk of cavitation, the inlet pressure for APP 30 - 38 must be min. 2 barg (29 psig) and 3.5 barg (50.8 psig). The inlet line connection must be properly tightened, as possible entrance of air will cause cavitation.

**2.4 General comments**

**Filtration**

A good filtration is vital to ensure a long and trouble-free life of the pump.

As water has very low viscosity, the APP pumps have been designed with very narrow clearance in order to control internal leakage rates and improve component performance. Therefore it is important that the inlet water is filtered properly to minimize the wear of the pump.

The main filter must have a filtration efficiency of 99.98% at 10 µm. We recommend to use precision depth filter cartridges rated 10 µm abs.  $\beta_{10} \geq 5000$  (equivalent to a filtration efficiency of 99.98%). Bag filters and string wounded filter cartridges typically have only 50% filtration efficiency. This means that for each 100,000 particles reaching the filter, 50,000 particles pass through it compared to only 20 particles in a filter with an efficiency of 99.98%.

For more information on the importance of proper filtration, please consult our publication "Filtration" (code number 521B1009), which also will provide you with an explanation of filtration definitions and a guidance on how to select the right filter.

**Monitoring**

It is recommended to continuously monitor the following conditions:

- Filter clogging
- Pressure (inlet- and outlet side of the pump)

**3. Building up the pump unit**

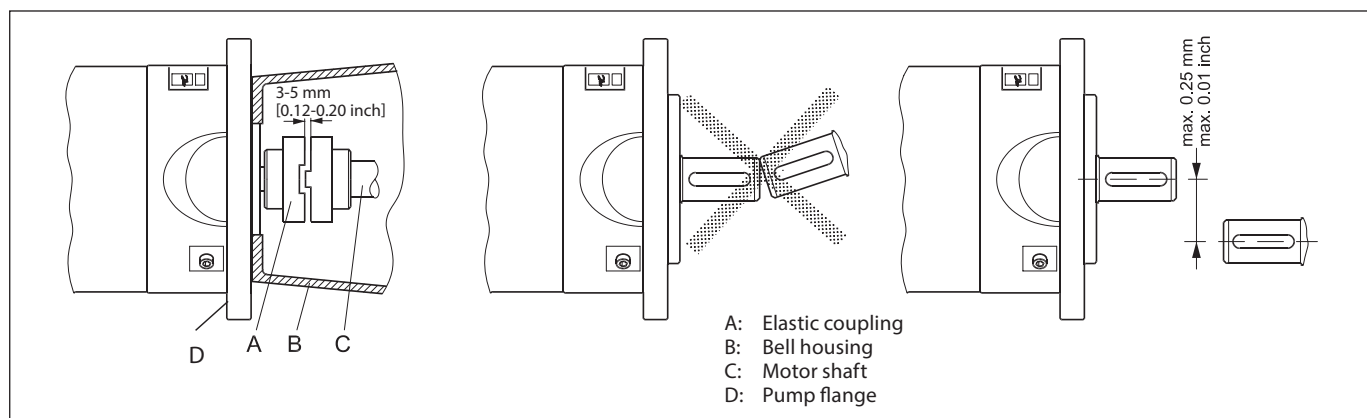

**3.1 Mounting**

1. Mount the coupling flush or maximum 1 mm offset from the pump shaft end. Ensure an air gap between coupling parts of 3-5 mm (0.12-0.2 inch).
2. Mount the bell housing on pump. Secure nuts with the right torque.
3. Measure the longest distance "A" from top of bell housing to the button of coupling claw.

4. Mount the coupling on motor shaft. Ensure the coupling and motor flange are not in contact with each other.
5. Measure from motor flange to the top of the coupling. That measurement "B" shall be 3-5 mm (0.12-0.2 inch) shorter than the measurement "A".

("A" and "B" can be found on the next page).

6. Adjust respectively, verify the measurement, and secure both couplings with the right torques on the locking screws (see coupling operation & mounting instruction).
7. Mount the elastic gear ring and mount the bell housing/pump on the motor. After mounting it must be possible to move the elastic gear ring 3-5 mm (0.12 - 0.2 inch) axial "C". The check can be done through the inspection hole of bell housing. Secure flange bolts with the right torque.

If alternative mounting is desired, please contact Danfoss High Pressure Pumps.

Choose proper tolerances to ensure an easy mounting of the elastic coupling without use of tools.

Please take care to observe the recommended length tolerances of the chosen coupling, as an axial force on the pump will damage the pump.

("C" can be found on the drawing below).

1: Bolts: torque 100 Nm ±10 Nm  
 2: Nuts: torque 40 Nm ±4 Nm  
 3: Torque see table below

Thread size	M5	M6	M8	M10
Torque (Nm)	2	4.8	10	17

**3.2 Direction of rotation**

Is indicated by an arrow on the pump label.

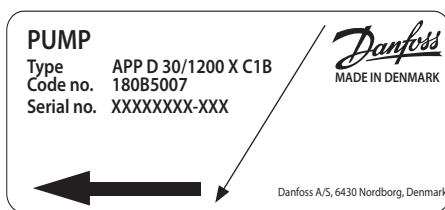

The valve should be placed as close to the pump as possible.

The opening characteristics of the valve must not result in peak pressures higher than 100 barg (1450 psig).

We recommend the use of flexible soft hoses both in the inlet and in the outlet lines.

**3.3 Orientation**

The pump can be mounted/orientated in any horizontal direction with the inlet and the outlet pointing upwards, downwards or to either side.

**3.4 Protection from too high pressures**

The pump should be protected against too high pressure by means of a safety valve or a pressure relief valve.

**3.5 Grounding**

To prevent stray current corrosion we recommend grounding of the pump and all other parts in the system. All parts in the system must be electrical potential equalized to a single reference point (grounding point). It is recommended that the electrical resistance in the grounding cable is equal to or below 0.25 Ω towards the grounding point.

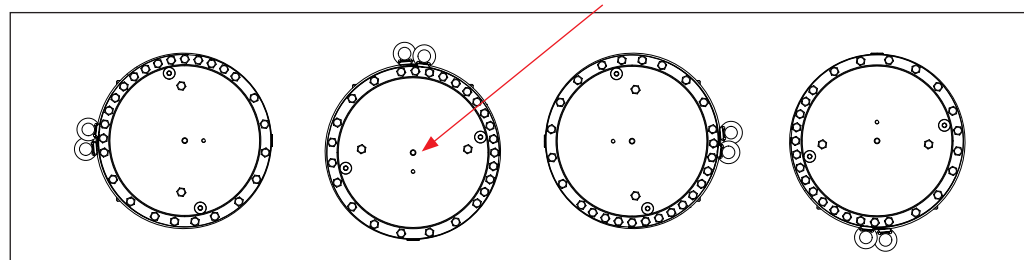

The valve outlet must not be connected directly to the pump suction line. It must be connected directly to the drain.

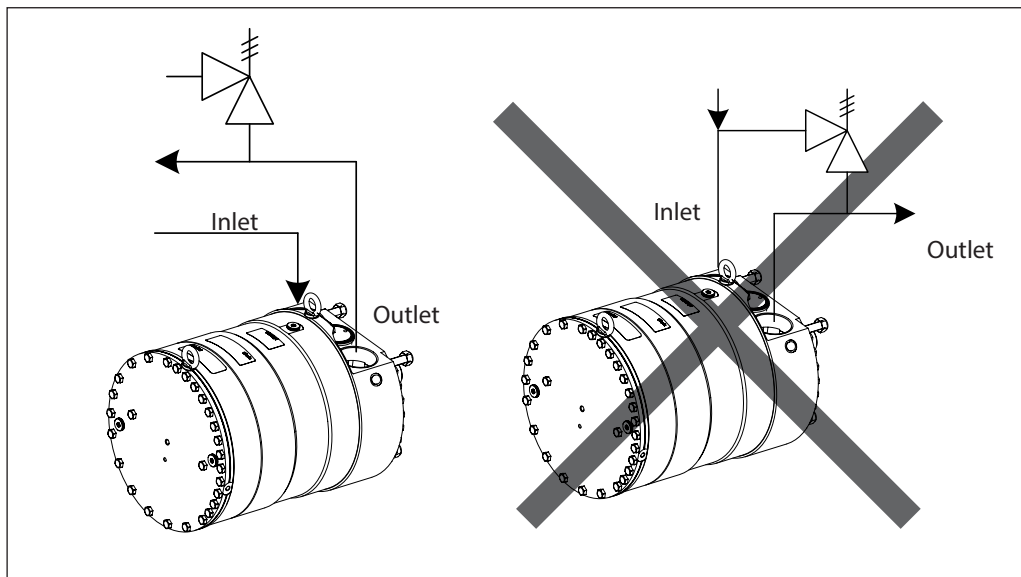

3.6 Connections

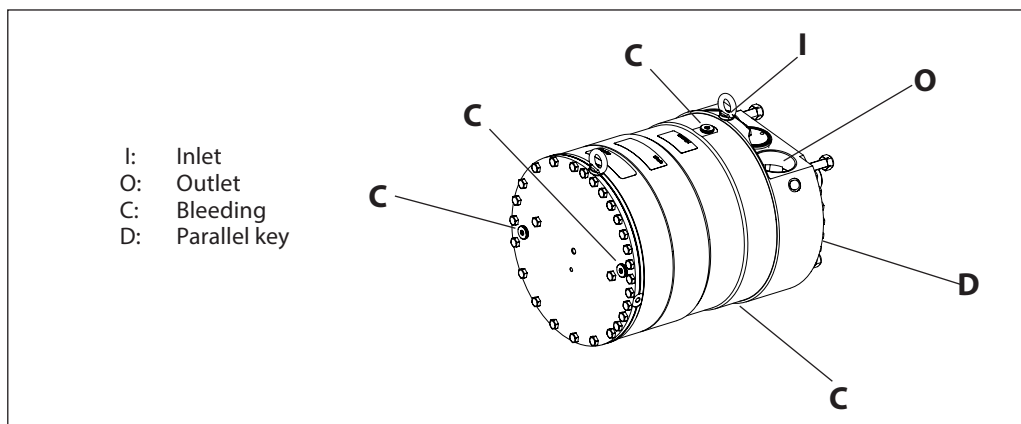

Description		APP 21 - 38 with ceramics	
E	Parallel key, DIN 6885	mm	12 × 8 × 70
		in	0.47 × 0.31 × 2.76
F	Bleeding	G ¼", Hexagon AF = 6 mm	
I	Inlet port	M60 x 1.5; depth 24 mm	
O	Outlet port	M60 x 1.5; depth 24 mm	
Mounting flange		ISO 3019-2 180B4TW	

Accessories	Type	Code no.	
3" inlet hose kit	3" Victaulic	180Z0144	2.00 m [79"]
2" outlet hose kit APP 21-38	2½" Victaulic	180Z0263	1.78 m [70"]
		180Z0280	1.00 m [39.4"]
3" inlet connector APP 21-38	3" Victaulic	180B3208	
Non-return valve (outlet) Super Duplex APP 21-38	2½" Victaulic (OD 73 mm)	180H0055	

For more details on the accessories, please contact Danfoss High Pressure Pumps. Possible extension see next page.

4. Initial start-up

1. Flush inlet line before connecting the pump, to remove possible impurities from pipes, hoses etc.
2. Connect pump inlet to inlet line and flush the pump for 5 min. by means of the internal flushing valve, to remove possible impurities from pipes, hoses etc.
3. Loosen top bleeding plug "C" (see item 3.5) using an allen key (only plugs with internal hexagan sockets). Retighten the plug, when water appears from the bleeding plug.
4. Make sure that the direction of rotation of the electric motor corresponds to the direction of rotation of the pump (see label on pump).
5. Now the pump is ready for start-up.

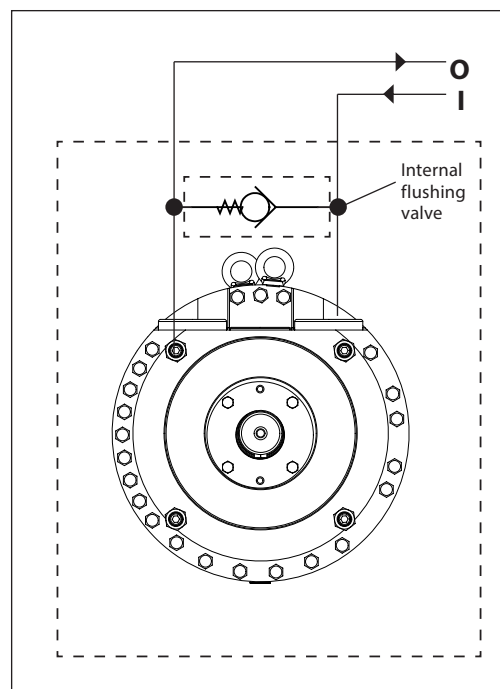

**WARNING**

**Make sure that the direction of rotation of the electric motor corresponds to the direction of rotation of the pump (see label on pump). Otherwise the pump will be damaged if a check valve is placed between pump and feed pump.**

5. Operation

5.1 Temperature

Fluid temperature: Min. +2°C to max. +50°C (Min. +35.6°F to max. +122°F)
Ambient temperature: Min. +2°C to max. +50°C (Min. +35.6°F to max. +122°F)

In case of lower operating temperatures, please contact Danfoss High Pressure Pumps.

The chart below illustrates the corrosive resistance of different types of stainless steel related to NaCl concentration and temperature.

The APP water pump is made of Duplex and Super Duplex.

If the water pump is operated above the Super Duplex line, always flush water pump with fresh water at operation stop in order to minimize the risk of crevice corrosion.

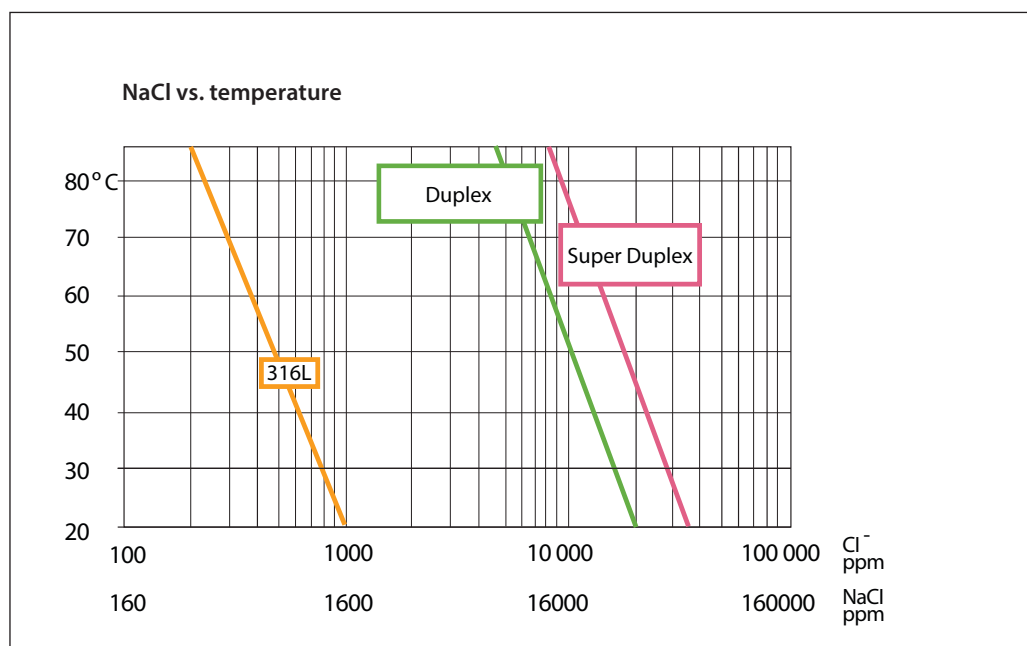

### 5.2 Pressure

The inlet pressure for APP 30 - 38 must be min. 2 barg (29 psig) and max. 5 barg (72.5 psig). At lower pressures the pump will cavitate, resulting in damage of the pump.

Max. inlet pressure peak (e.g. in case the pump stops momentarily) up to 10 barg (145 psig) are acceptable.

Max. pressure on the pump's outlet line should be limited at 83 barg (1200 psig) continuously.

Note: The pump unit should include a pressure gauge on the high-pressure side.

### 5.3 Dry running

When running, the pump must always be connected to the water supply in order to avoid damage if it should run dry.

### 5.4 Disconnection

If the inlet line is disconnected from the water supply, the pump will be emptied of water through the disconnected inlet line.

When starting up again, follow the bleeding procedure described under section 4: Initial start up.

### 5.5 Storage

Storage temperature:  
Min. -40°C to max. +70°C  
(Min. -40°F to max. +158°F)

When preparing the pump for long-term storage or for temperatures below the freezing point, flush the pump with an anti-freeze medium type monopropylene glycol to prevent internal corrosion or frost in the pump.

For further information on anti-freeze media, please contact Danfoss High Pressure Pumps.

#### Recommended procedure:

1. Disconnect the water supply to the pump.
2. Through the lower bleeding plug, empty the pump housing of water and close it again.
3. Connect the pump to a tank containing anti-freeze additive. Connect a hose to the inlet port of the pump and via another hose return the flow from the outlet port to the tank with antifreeze additives.
4. Quickly start and stop the pump. **Make sure that the pump does not run dry.** The pump is now protected against internal corrosion and frost.

#### Storage:

Storage of pump that have been in operation: For shorter periods of storage flush the pump with permeate rotating the pump for 10 sec., empty permeate and store.

For long term storage (more than 2 months) Danfoss recommends servicing the product and clean any biological growth of the surface. Store the pump dry without water inside.

## 6. Service

### 6.1 Warranty

Danfoss APP pumps are designed for long operation, low maintenance and reduced lifecycle costs.

Provided that the pump has been running according to the Danfoss specifications, Danfoss recommends 16.000 hours service interval, but as the guarantee is 8000 Hours service free operation or max. 18 month from date of production it is recommended to perform an inspection before the end of the warranty period to ensure that any potential issues are identified and can be resolved promptly through the warranty claims process

If Danfoss recommendations concerning system-design are not followed, it will strongly influence the life of the APP pumps.

### 6.2 Maintenance

After 16,000 hours of operation, **it is strongly recommended** to inspect the pump and change any worn parts, e.g. pistons and shaft seal. This is done in order to prevent a potential breakdown of the pump.

If the parts are not replaced, more frequent inspection is recommended according to our guidelines.

#### Standstill:

The APP pumps are made of Duplex/Super Duplex materials with excellent corrosion properties. **It is however, always recommended to flush the pump with fresh water when the system is shut down.**

When stopping the pump for more than 1 day flush the pump with permeate by rotating the pump for 10 sec. Flushing through the flushing valve of the pump without rotating the pump is not enough for cleaning the inside of the pump. The pump can be flushed with biocide like the membranes. The biocide must be compatible with the materials used in our pump (materials can be found in the parts list in the Operating guide.

### 6.3 Repair

In case of irregular function of the APP, please contact Danfoss High Pressure Pumps sales organisation.

## Danfoss A/S

High Pressure Pumps • danfoss.com • +45 7488 2222 • highpressurepumps@danfoss.com

All information, including, but not limited to information on selection of product, its application or use, product design, weight, dimensions, capacity or any other technical data in product manuals, catalogues descriptions, advertisements, etc. and whether made available in writing, orally, electronically, online or via download, shall be considered informative, and is only binding if and to the extent, explicit reference is made in a quotation or order confirmation. Danfoss cannot accept any responsibility for possible errors in catalogues, brochures, videos and other material. Danfoss reserves the right to alter its products without notice. This also applies to products ordered but not delivered provided that such alterations can be made without changes to form, fit or function of the product.

All trademarks in this material are property of Danfoss A/S or Danfoss group companies. Danfoss and the Danfoss logo are trademarks of Danfoss A/S. All rights reserved.