



iC7 Series Propulsion and Machinery

iC7-Marine



Contents

1	Introduction to App Guide	7
1.1	Version History	7
1.2	Purpose of this Application Guide	7
1.3	Additional Resources	7
1.4	Safety Symbols	8
2	Application Software Overview	9
2.1	Propulsion and Machinery Application Software Overview	9
2.1.1	General Features	9
2.1.2	Motor Control Features	11
2.1.3	Protection Features	12
2.1.4	Security Features	13
2.1.5	Functional Safety	13
2.1.6	Logic Feature	13
2.1.7	Master Follower	13
2.2	Fieldbus Control Profile Descriptions	13
2.2.1	iC Generic Profile	14
2.2.2	iC Speed Profile	16
2.2.3	PROFIdrive® Application Class 1 Profile	18
2.2.4	CiA-402 Velocity Mode Profile	21
3	User Interfaces and How to Configure	27
3.1	Overview of User Interfaces	27
3.2	Control Panel	27
3.2.1	iC7 Control Panel Options	27
3.2.2	Control Panel Elements	28
3.2.3	Control Panel Basic Configurations	29
3.2.4	Control Panel Shortcuts	35
3.3	MyDrive® Insight	36
3.3.1	Getting Started with MyDrive® Insight	36
3.3.2	Accessing Parameters and Understanding Parameter Screens in MyDrive® Insight	38
3.3.3	PC Control to Operate the Drive Using MyDrive® Insight	41
3.3.4	Datalogger	42

3.3.5	Backup and Restore	46
4	Application Software Structure and Overview	51
4.1	Parameter Groups, Related Content, and Settings.....	51
5	Configuration Examples	53
5.1	Introduction and Prerequisites	53
5.2	Basic Setup of the Drive	53
5.3	Configuring Motor and Motor Control	54
5.4	Configuring Speed Control.....	56
5.5	Configuring Torque Control	58
5.6	Configuring Power Control.....	61
6	Parameter Lists	63
6.1	How to read parameter lists	63
6.1.1	Understanding Data Types.....	63
6.2	Monitoring	64
6.2.1	Basic Monitoring	64
6.2.2	Control Mode and Reference Monitoring	64
6.2.3	Limit Monitoring	65
6.2.4	Control Place Monitoring.....	65
6.2.5	Speed Control Monitoring	65
6.2.6	Torque Control Monitoring.....	66
6.2.7	Power Control Monitoring	66
6.2.8	Motor Control Monitoring	66
6.2.9	Drive Control Monitoring.....	67
6.2.10	Protection Monitoring	67
6.2.11	Mechanical Brake Control Monitoring.....	68
6.2.12	Custom Status Word Monitoring	68
6.2.13	Power Unit Monitoring	68
6.2.14	Rectifier Monitoring.....	68
6.2.15	Advanced Harmonic Filter Monitoring.....	68
6.2.16	Fieldbus Process Data Monitoring	69
6.2.17	Functional Safety Monitoring	69
6.2.18	Date & Time Monitoring	70

6.2.19	Logic Monitoring	70
6.2.20	Master Follower Monitoring	70
6.2.21	I/O And Relay Status	70
6.2.22	Encoder/Resolver Status	70
6.2.23	Temperature Measurement Status	71
6.3	Parameters	71
6.3.1	Basic Parameters	71
6.3.2	Control Mode and References	71
6.3.3	Limits	76
6.3.4	Ramps	79
6.3.5	Digital and Analog Inputs	81
6.3.6	Digital and Analog Outputs	83
6.3.7	Start and Stop Settings	86
6.3.8	Control Places	87
6.3.9	Motor Control	89
6.3.10	Speed Control	93
6.3.11	Drive Control	94
6.3.12	Protections and Responses	95
6.3.13	Mechanical Brake Control	101
6.3.14	Motor Breaker Control	102
6.3.15	Output Filter	102
6.3.16	Inching	102
6.3.17	Advanced Harmonic Filter	103
6.3.18	Master Follower	103
6.3.19	Logic Settings	104
6.4	Maintenance & Service	104
6.4.1	Software Information	104
6.4.2	Events	104
6.4.3	Operational Counters	105
6.4.4	I/O Testing	105
6.4.5	Backup & Restore	106
6.4.6	Expert Tools	106

6.5	Functional Safety.....	106
6.5.1	Basic Settings	106
6.5.2	STO	107
6.5.3	SS1	107
6.6	Device Settings.....	107
6.6.1	Time & Units.....	107
6.6.2	Control Panel.....	107
6.6.3	Custom Status Word	108
6.7	Option Board Settings	108
6.7.1	I/O And Relay	108
6.7.2	Encoder/Resolver	111
6.7.3	Temperature Measurement	112
6.8	Connectivity	114
6.8.1	Integrated Communication	114
6.8.2	RS485 Communication OC7F3	116
7	Parameter Descriptions	117
7.1	How to Read Parameter Descriptions.....	117
7.2	Monitoring	117
7.2.1	Basic Monitoring	117
7.2.2	Control Mode and Reference Monitoring	123
7.2.3	Limit Monitoring	124
7.2.4	Control Place Monitoring.....	124
7.2.5	Speed Control Monitoring	125
7.2.6	Torque Control Monitoring.....	126
7.2.7	Power Control Monitoring	127
7.2.8	Motor Control Monitoring	127
7.2.9	Drive Control Monitoring.....	130
7.2.10	Protection Monitoring	130
7.2.11	Mechanical Brake Control Monitoring.....	131
7.2.12	Custom Status Word Monitoring	131
7.2.13	Power Unit Monitoring	131
7.2.14	Rectifier Monitoring.....	132

7.2.15	Advanced Harmonic Filter Monitoring.....	133
7.2.16	Fieldbus Process Data Monitoring	133
7.2.17	Functional Safety Monitoring	135
7.2.18	Date & Time Monitoring	135
7.2.19	Logic Monitoring	135
7.2.20	Master Follower Monitoring.....	136
7.2.21	I/O And Relay Status	136
7.2.22	Encoder/Resolver Status.....	136
7.2.23	Temperature Measurement Status	136
7.3	Parameters.....	137
7.3.1	Basic Parameters.....	137
7.3.2	Control Mode and References	141
7.3.3	Limits.....	171
7.3.4	Ramps.....	194
7.3.5	Digital and Analog Inputs	199
7.3.6	Digital and Analog Outputs	205
7.3.7	Start and Stop Settings.....	213
7.3.8	Control Places	224
7.3.9	Motor Control	239
7.3.10	Speed Control.....	249
7.3.11	Drive Control	255
7.3.12	Protections and Responses	261
7.3.13	Mechanical Brake Control.....	290
7.3.14	Motor Breaker Control.....	295
7.3.15	Output Filter.....	301
7.3.16	Inching.....	302
7.3.17	Advanced Harmonic Filter.....	305
7.3.18	Master Follower	306
7.3.19	Logic Settings	308
7.4	Maintenance & Service	309
7.4.1	Software Information.....	309
7.4.2	Events.....	309

7.4.3	Operational Counters.....	312
7.4.4	I/O Testing.....	313
7.4.5	Backup & Restore.....	315
7.4.6	Expert Tools.....	315
7.5	Functional Safety.....	316
7.5.1	Basic Settings	317
7.5.2	STO	318
7.5.3	SS1	319
7.6	Device Settings.....	319
7.6.1	Time & Units.....	319
7.6.2	Control Panel.....	321
7.6.3	Custom Status Word	323
7.7	Option Board Settings.....	327
7.7.1	I/O And Relay	327
7.7.2	Encoder/Resolver	333
7.7.3	Temperature Measurement	339
7.8	Connectivity	345
7.8.1	Integrated Communication	345
7.8.2	RS-485 Communication OC7F3	349
8	Troubleshooting.....	351
8.1	Viewing and Resetting Events.....	351
8.2	How to read the event summary table.....	351
8.3	Events Summary for Propulsion and Machinery	352

1 Introduction to App Guide

1.1 Version History

Version	Remarks	Software Version
AB426216167632, version 0801	Updated for General Release 4.	Application software version 5.3.0 Firmware version 5.36.2
AB426216167632, version 0701	Updated for General Release 3.	Application software version 5.2.2 Firmware version 5.28.2
AB426216167632, version 0601	General Release 2 patch update.	Application software version 5.1.4 Firmware version 5.17.7
AB426216167632, version 0501	Updated for General Release 2.	Application software version 5.1.1 Firmware version 5.17.0
AB426216167632, version 0401	General Release 1 patch update.	Application software version 5.0.3 Firmware version 5.6.11
AB426216167632, version 0301	Updated for General Release 1.	Application software version 5.0.0 Firmware version 5.6.6
AB426216167632, version 0201	Migration from Tech Pub Studio to Ixiasoft editor program.	Application software version 2.2.4. Firmware version 3.4.3
AB426216167632, version 0101	Updated for Controlled Release.	Application software version 2.2.4. Firmware version 3.4.3

1.2 Purpose of this Application Guide

This application guide provides information on operating the Propulsion and Machinery application of the iC7 Series. The application guide provides an overview of parameters and value ranges for operating the drive. In addition to drive parameters, information on the various user interfaces to configure drive parameters, configuration examples with recommended parameter settings, and troubleshooting steps are included in the application guide.

Intended Audience

The intended audience of the application guide is trained personnel, automation engineers, and configurators with experience in operating with parameters and with basic knowledge of Danfoss AC drives.

1.3 Additional Resources

Additional resources are available with related information.

The design guide provides information about the capability and functionality to design drive systems with the iC7 series.

The operating guide provides detailed specification, requirements, and installation instructions of the iC7 series drives.

Protocol specific fieldbus Operating Guides provide details on how to configure and use a specific fieldbus protocol with iC7 series drives.

The control panel user guide provides detailed specifications and operations to use the various control panel portfolios of the iC7 series.

1.4 Safety Symbols

DANGER

Indicates a hazardous situation which, if not avoided, will result in death or serious injury.

WARNING

Indicates a hazardous situation which, if not avoided, could result in death or serious injury.

CAUTION

Indicates a hazardous situation which, if not avoided, could result in minor or moderate injury.

NOTICE

Indicates information considered important, but not hazard-related (for example, messages relating to property damage).

2 Application Software Overview

2.1 Propulsion and Machinery Application Software Overview

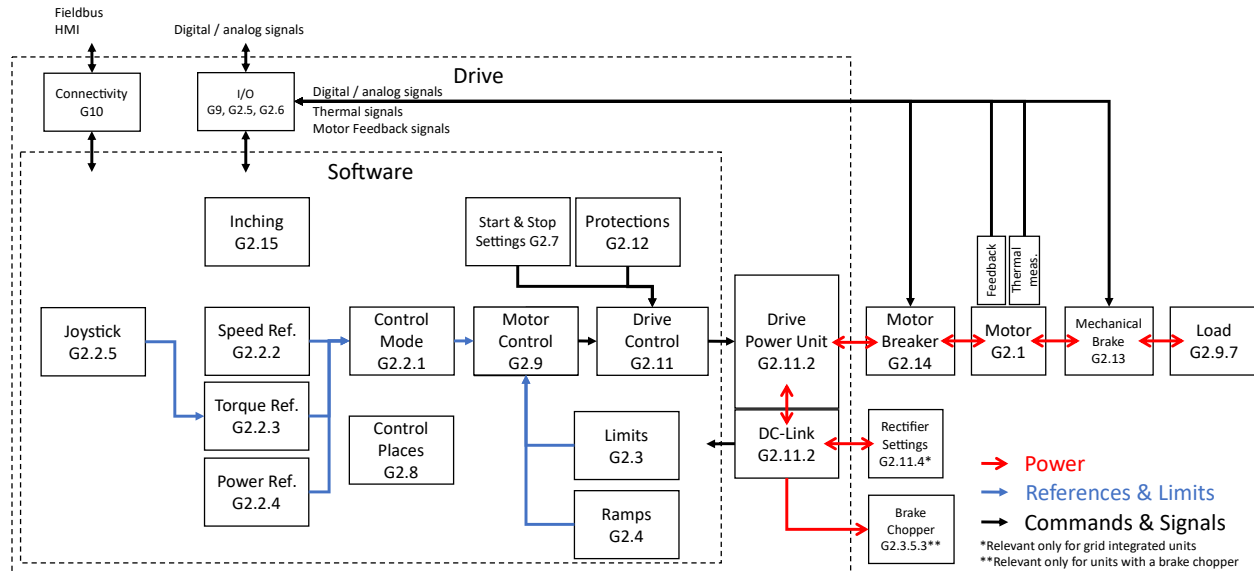

Figure 1: Overview of P&M application software.

The Propulsion and Machinery (P&M) application software is controlled through interfaces such as digital and analog I/O, fieldbus, drive control panel, and MyDrive® Insight (**G2.5**, **G2.6**, **G9**, **G10**). These interfaces influence the software through commands and feedback signals that affect various parts of the software. Likewise, the software can use these same interfaces for sending out commands and status information.

The different control interfaces form control places (**G2.8**), which can work either separately or in parallel. They provide, for instance, starting and stopping commands, various references, and limits for the drive. These commands, references, and limits travel through the software and finally form modulation commands (**G2.11**) for the power unit (**G2.11.2**), which in turn powers the motor.

The different control modes (Speed, Torque, and Power) are selected with the Control Mode group (**G2.2.1**), after which additional motor control details (**G2.9**) can be further configured. Control of the motor is also influenced by other software components such as protections (**G2.12**), start and stop settings (**G2.7**), limits (**G2.3**), and Ramps (**G2.4**).

External devices such as thermal probes, encoders, or a mechanical brake (**G2.13**) can also be configured to influence motor and drive control. If the devices can provide any kind of feedback or receive commands, they can be transmitted through the different I/O interfaces (**G9**, **G2.5**, **G2.6**).

2.1.1 General Features

The application software provides a wide range of built-in features for drive security, drive services, and protection for the drive, gear, and motor.

Control Modes

Three different control modes are supported: speed, torque, and power. These modes define whether the main control variable is the motor speed, torque, or power, and whether a speed or torque-based control loop is used to control the drive. Modes can be set per each control place and changed with a preset function via digital inputs or fieldbus signals.

Control Places

Five different control places are offered for determining how basic drive commands and references are interfaced. These control places are: MyDrive® Insight, Local Control (control panel), Fieldbus Control, I/O Control, and Advanced Control. The active control place can be selected with a parameter or using different overrides. Each control place has a set of control commands, and references.

Reference Handling

References can be controlled via multiple source interfaces such as: analog inputs, digital inputs with a pulse mode or as a digital potentiometer, fieldbus process data, presets, and control panel or MyDrive® Insight. Most reference sources can be combined and scaled.

Ramps

Two individual speed ramp presets can be defined and selected with digital inputs or fieldbus signals. Both the accelerating and decelerating parts, and smoothing curvatures can be configured individually for both ramps.

Also, both the torque and power control modes feature reference and limit ramps that have ramp-rates configurable via parameters or fieldbus signals.

Limit Control

The application features several different limits which can be controlled: speed limit, torque limit, power limit, current limit, and DC-link over and undervoltage limits. Most of these limits are controllable through parameters, analog inputs, and fieldbus signals.

Quick Stop

In some situations, such as emergencies, it may be required to stop the motor quicker than usual. For this purpose, the drive supports a specific quick stop function. This sort of stop can also be associated with a configurable event.

Speed Bypass

Specific motor speeds can be bypassed with this function. It helps minimize and avoid mechanical resonance of the machine, limiting vibration and noise of the system.

Load Drooping

The load droop function ensures that multiple motors, each controlled by a drive and connected to a mechanical common shaft, share the load in a balanced manner. The function is typically used in cranes, winches, or larger conveyor systems controlled by 2 or more motors. This feature is also configurable with a linear removal function and a master-follower-type assistance function designed specifically for winch applications.

Mechanical Brake Control

In applications like cranes, lifts, and hoists a mechanical brake is used to keep the load at standstill, when the motor is not controlled by the drive. The mechanical brake control feature ensures a smooth transition between the mechanical brake and the motor holding the load, by controlling the activation and deactivation of the mechanical brake.

Interlocking

Interlocking can be used to block the drive from starting if external systems do not allow it. This feature can be used to integrate externally controlled devices, such as motor switches, with the drive. There are two types of interlocks, Start & Run Interlocks.

Motor Breaker Control

The motor breaker control feature makes it possible to open, close, and monitor a breaker installed between the drive and a motor. The breaker can be either automatically controlled by the drive, or manually controlled through the drive, while monitoring the state of the breaker. Both one-wire and two-wire control and feedback signals are supported.

2.1.2 Motor Control Features

2.1.2.1 Motor Types

The application supports standard asynchronous induction motors and synchronous permanent magnet motors.

2.1.2.2 Load Characteristics

Both constant and variable torque load characteristics are supported to match the actual application needs.

- Constant torque: Load characteristic used in machinery where torque is needed across the full speed range. Typical application examples are conveyors, extruders, decanters, compressors, and winches.
- Variable torque: Typical load characteristic of fans and centrifugal pumps, where the load is proportional to the square of the speed.

2.1.2.3 Motor Control Principles

Different control principles can be selected to adjust the control of the motor, and to match it with the needs of the application.

- U/f control for simple open-loop operation.
- VVC+ (Voltage Vector Control) in both open and closed loop, for the general-purpose application needs.
- FVC+ (Flux Vector Control) in both open and closed loop, for demanding application needs.

2.1.2.4 Automatic Motor Adaptation

Automatic Motor Adaptation (AMA) provides optimization of motor parameters for improved shaft performance. Based on motor nameplate data and measurements of the motor at standstill, key motor parameters are being recalculated, and used to fine-tune the motor control algorithm. AMA also allows automatic detection of the motor type.

2.1.2.5 Braking of load

For controlled load braking performed by the drive, various functions can be used. The specific function is selected based on the application and the needs for how fast it must be stopped.

Resistor Braking

In applications which require fast or continuous braking, a drive fitted with a brake chopper is typically used. Excess energy, generated by the motor during braking, is dissipated in a brake resistor connected to the drive's DC link. Braking performance depends on the specific drive type, rating, and the selected brake resistor.

Overvoltage Control

If braking time is not critical or the load is varying, the Over Voltage Control feature is used to control braking of the motor. The drive extends the ramp down time when it is not possible to brake within the defined ramp down period. The feature must not be used in hoisting applications, high inertia systems, or applications where continuous braking is required. For such applications this feature can be disabled.

DC Brake

When braking at low speed, the braking of the motor can be improved by using the DC brake feature. The software offers configurable DC-braking for induction motor control. It injects a predefined DC current.

AC Brake

In applications with non-cyclic operation of the motor, AC braking can be used to shorten the braking time. Excess energy is dissipated by increasing losses in the motor during braking. Performance is motor type dependent and offers best performance on induction motors.

2.1.3 Protection Features

2.1.3.1 Drive Protection Features

The drive is monitored and protected during operation. Inbuilt temperature sensors measure the actual temperature and provide relevant information to protect the drive. If the temperature exceeds its nominal temperature conditions, derating of operational parameters is applied. If the temperature is outside the allowed operating range, the drive stops operation.

Motor current is continuously monitored on all three phases. If there is a short circuit between two phases or a fault to ground, the drive detects the short circuit and immediately turns off. If the output current exceeds its nominal values during operation for longer periods than allowed, the overload capability is reduced until the conditions are restored.

DC-link voltage of the drive is monitored. If it exceeds critical levels, a warning is issued and if the situation is not resolved, the drive stops operation.

2.1.3.2 Motor Protection Features

The drive provides various features to protect the motor and the application. The output current measurement provides information to protect the motor. Overcurrent, short circuits, ground faults, and lost motor phase connections can be detected, and relevant protections initiated. Monitoring speed, current and torque limits provides an extra protection for the motor and the application. Under extreme load conditions, it also provides motor stall protection.

2.1.3.3 Automatic Derating

Automatic derating of the drive allows continued operation even if the nominal operation conditions are exceeded. Typical affecting factors are temperature, high DC-link voltage, high motor load, or operation close to 0 Hz. Derating is typically applied as a reduction in switching frequency or a change in the switching pattern, resulting in lower thermal losses.

2.1.4 Security Features

The application software provides the following cybersecurity features:

- Signed and encrypted firmware.
- Secure firmware updates.
- User account and permission management.
- License verification
- Secure protocol for all communication interfaces
- Protection while remotely accessing the drive
- Prevent code execution via interfaces
- Firewall to protect the network from unauthorized access. Disable unused ports, interfaces, and service.

2.1.5 Functional Safety

A Safe Torque Off (STO) function with dual input is available as standard in the drive. An additional Safe Torque Off feedback signal indicates the status of the drive. More functional safety features are available as optional selections. The set of features covers a wide range of functional safety functions that can operate in both sensorless and closed-loop setup. A safe fieldbus is also supported as an option.

2.1.6 Logic Feature

Logic is a versatile feature that allows the customization and control of the operation of the drive without the need for a separate programming tool or language. By utilizing Logic, the operation of the drive can be customized using a limited number of programmable function blocks and a limited number of states. Logic in MyDrive® Insight extends the features of the drive and provides increased flexibility. Logic enables applying conditional controls, implementing fault detection and diagnostics, creating sequencing, modes, states, and interlocking logic. Refer to the *MyDrive® Insight Logic Feature Application Guide* for more comprehensive information about the feature.

2.1.7 Master Follower

The master follower will be a feature that allows defining one drive as the master and the others as followers in multidrive applications. The followers can be set to follow the commands (start, stop, and so on) and references (speed, torque, power) of the master. However, this feature is still under development and the parameters of group **2.18** must not be touched.

NOTICE

The Master Follower feature is still under development. Do not touch the parameters of group **2.18**.

2.2 Fieldbus Control Profile Descriptions

The following chapters describe the behavior of the different fieldbus profiles available in the Propulsion and Machinery application. A profile describes a specific way to interpret the fieldbus

Control and Status Words, and possibly follow a state machine. Use parameter **No. 1301 Fieldbus Profile** to select different profiles. Use parameters **No. 1335** and **No. 1307** to monitor the incoming fieldbus Control Word and Status Word values.

2.2.1 iC Generic Profile

The following describes the behavior of the iC Generic profile, which is the default profile of this application software. It is a simple profile suitable for controlling a Propulsion drive in any Control Mode. All commands are interpreted as is, without any state machine logic.

NOTICE

The availability of the iC Generic Profile can depend on the used fieldbus protocol. Refer to the protocol specific documentation and possible device description files to see whether this profile is supported or not.

2.2.1.1 Control Word Description

The following table describes the function of each bit in the fieldbus control word, when using iC Generic Profile.

Bit	Value	Significance	Comments
0	0	Ramp Stop	A running drive stops with a ramp. The drive cannot be started.
	1	No Ramp Stop	The ramp stop request is inactive. The drive can be started.
1	0	Coast Stop	A running drive coasts to a stop. The drive cannot be started.
	1	No Coast Stop	The coast request is inactive. The drive can be started.
2	0	Quick Stop	Drive stops with the Quick Stop function.
	1	No Quick Stop	The Quick Stop request is inactive. The drive can be started.
3	0	No Start	The drive stops operating with the method determined by the No. 4717 Missing Start parameter.
	1	Start	The drive starts to operate on the rising edge of this signal.
4-6	0	No significance	
	1	No significance	
7	0	Event Reset Inactive	The rising edge of this signal will reset events (warnings, faults, and so on), which do not have active triggering conditions. After a fault the drive will go to a Switching On Inhibited state, which must be acknowledged with bit 0.
	1	Event Reset Active	
8	0	Reference Reverse Off	The speed reference remains normal.
	1	Reference Reverse On	The speed reference is reversed. Note: the reference can also be reversed with a negative setpoint. Double negatives result in a forward reference.
9	0	No significance	
	1	No significance	
10	0	Data Invalid	Ignores the current Process Data. Uses the previously processed data when the Data valid bit was previously true.
	1	Data Valid (Control by PLC)	Reads the current Process Data. Note: For most of the control word's commands to be acknowledged by the drive, fieldbus must also be the commanding control place. See options in group G2.8.1 .
11	0	Watchdog Low	With continuous toggling between 0 and 1 this bit can be used as a sign-of-life between the drive and the fieldbus master. The value of this bit is also passed through the fieldbus status word as is.
	1	Watchdog High	

Bit	Value	Significance	Comments
12	0	Fieldbus Digital Input 1 Inactive	Select the value CTW B12 for any Input parameter to utilize this signal for the activation of a desired function.
	1	Fieldbus Digital Input 1 Active	
13	0	Fieldbus Digital Input 2 Inactive	Select the value CTW B13 for any Input parameter to utilize this signal for the activation of a desired function.
	1	Fieldbus Digital Input 2 Active	
14	0	Fieldbus Digital Input 3 Inactive	Select the value CTW B14 for any Input parameter to utilize this signal for the activation of a desired function.
	1	Fieldbus Digital Input 3 Active	
15	0	Fieldbus Digital Input 4 Inactive	Select the value CTW B15 for any Input parameter to utilize this signal for the activation of a desired function.
	1	Fieldbus Digital Input 4 Active	

2.2.1.2 Status Word Description

The following table describes the function of each bit in the fieldbus status word, when using iC Generic Profile.

Bit	Value	Significance	Comments
0	0	Not Ready To Switch On	The drive is not ready to receive a start command because at least one of the following conditions is true: Fault Active, Ramp Stop Active, Coast Stop Active, or Quick Stop Active.
	1	Ready To Switch On	The drive is ready to accept a start command.
1	0	Power Unit Not Ready	The drive cannot run because the power unit ready conditions are not met. Check No. 6207 for any unmet conditions.
	1	Power Unit Ready	All power unit ready conditions are met.
2	0	Drive Stopped	The drive is not running.
	1	Drive Running	The drive is running.
3	0	Faults Inactive	All drive faults are inactive.
	1	Fault Active	One or more drive faults are active. Note: switching on is inhibited.
4	0	No significance	
	1	No significance	
5	0	Quick Stop Not Active	The quick stop command is inactive. Note: a new start command is required.
	1	Quick Stop Active	The quick stop command is active. Note: This command can also be given from another control source than fieldbus.
6	0	No significance	
	1	No significance	
7	0	Warnings Inactive	All drive warnings are inactive.
	1	Warning Active	One or more drive warnings are active
8	0	No significance	

Bit	Value	Significance	Comments
	1	No significance	
9	0	Fieldbus Control Inactive	Fieldbus is not the commanding control place.
	1	Fieldbus Control Active	Fieldbus is the commanding control place.
10	0	No significance	
	1	No significance	
11	0	Run Disabled	The digital input signal No. 103 is inactive and thus modulation is disabled.
	1	Run Enabled	The digital input signal No. 103 is active and thus modulation is enabled.
12 -	0	No significance	
	1	No significance	
14	0	No significance	
	1	No significance	
15	0	Watchdog Feedback Low	The watchdog signal that the drive has received is low.
	1	Watchdog Feedback High	The watchdog signal that the drive has received is High.

2.2.2 iC Speed Profile

The following describes the behavior of the iC Speed profile, which is an all-purpose speed control profile common between all iC7 motor applications. This profile does not follow a state machine. All commands are directly interpreted as such.

2.2.2.1 Control Word Description

The following table describes the function of each bit in the fieldbus control word, when using iC Speed Profile.

Bit	Value	Significance	Comments
0	0	Speed Preset Reference Selector 1	Use these two bits to select between Speed Presets: 00 = Preset Reference 1 01 = Preset Reference 2 10 = Preset Reference 3 11 = Preset Reference 4
	1		
1	0	Speed Preset Reference Selector 2	
	1		
2	0	No significance	
	1		
3	0	Coast Stop	Drive coasts to a stop.
	1	No Coast Stop	The coast request is inactive. The drive can be started.
4	0	Quick Stop	Drive stops with the Quick stop function.
	1	No Quick Stop	The Quick Stop request is inactive. The drive can be started.
5	0	Freeze Speed Reference	The speed reference (input of the ramp generator) is frozen to its latest value.
	1	Unfreeze Speed Reference	The speed reference can be changed freely.
6	0	No Start	The drive stops operating with the method determined by the No. 4717 Missing Start parameter.
	1	Start	The drive starts to operate on the rising edge of this signal.
7	0	Event Reset Inactive	The rising edge of this signal resets events (warnings, faults, and so on),

Bit	Value	Significance	Comments
	1	Event Reset Active	which do not have active triggering conditions.
8	0	Inching 1 Off	The speed reference can be set freely. The drive may stop depending on the inching settings and whether start is inactive.
	1	Inching 1 On	The drive may ramp to the Inching 1 preset reference according to the Inching feature's settings in group 2.15 .
9	0	Speed Ramp 1 Active	Configure ramp 1 in G2.4.1.2 .
	1	Speed Ramp 2 Active	Configure ramp 2 in G2.4.1.3 .
10	0	Data Invalid	Ignores the current Process Data. Uses the previously processed data when the Data valid bit was previously true.
	1	Data Valid (Control by PLC)	Reads the current Process Data. Note: For most of the control word's commands to be acknowledged by the drive, fieldbus must also be the commanding control place. See options in group 2.8.1 .
11	0	No significance	
	1	No significance	
12	0	Fieldbus Digital Input 1 Inactive	Select the value CTW B12 for any Input parameter to utilize this signal for the activation of a desired function.
	1	Fieldbus Digital Input 1 Active	
13	0	Fieldbus Digital Input 2 Inactive	Select the value CTW B13 for any Input parameter to utilize this signal for the activation of a desired function.
	1	Fieldbus Digital Input 2 Active	
14	0	Fieldbus Digital Input 3 Inactive	Select the value CTW B14 for any Input parameter to utilize this signal for the activation of a desired function.
	1	Fieldbus Digital Input 3 Active	
15	0	Fieldbus Digital Input 4 Inactive	Select the value CTW B15 for any Input parameter to utilize this signal for the activation of a desired function.
	1	Fieldbus Digital Input 4 Active	

2.2.2.2 Status Word Description

The following table describes the function of each bit in the fieldbus status word, when using iC Speed Profile.

Bit	Value	Significance	Comments
0	0	Control not ready	The device controls are not ready and do not react to process data.
	1	Control ready	The device controls are ready and react to process data.
1	0	Drive not ready	The drive is not ready to operate.
	1	Drive ready	The drive is ready for operation.
2	0	Coast active	There is an active coast stop command and the drive is in a coast stop state.
	1	Coast inactive	There are no active coast signals. The drive can be started.
3	0	Faults inactive	There are no active faults.
	1	Faults active	There is at least one active fault. The drive cannot be started before the

Bit	Value	Significance	Comments
			fault condition is cleared and the fault is reset.
4	0	No significance	
-	1		
6			
7	0	Warnings inactive	There are no active warnings.
	1	Warnings active	There is at least one active warning. The source of the warning must be investigated and mitigated.
8	0	Speed not at reference	The motor speed differs from the given speed reference. Could be due to ramping, for example.
	1	Speed at reference	The motor speed matches the given speed reference.
9	0	Fieldbus control inactive	None of the drive's basic command functions are affected by fieldbus commands.
	1	Fieldbus control active	Fieldbus is the active control place, or configured as part of the Advanced Control Place.
10	0	Limiter inactive	All limiters (regulators) are inactive.
	1	Limiter active	One or more limiter (regulator) is actively limiting the drive current, torque and so on. See No. 1715 for further details.
11	0	Drive stopped	The drive is not modulating (operating).
	1	Drive running	The drive is modulating (operating).
12	0	No significance	
-	1		
15			

2.2.3 PROFdrive® Application Class 1 Profile

The Propulsion and Machinery application features the Standard telegram 1 of PROFdrive® Application Class 1 as defined in the PROFdrive® standard. This telegram is available through the associated fieldbus profile. This profile follows a state machine. A specific sequence of commands is required to move from one state to another.

When this profile is selected, the scaling of the main (speed) reference and actual value is automatically set according to the N2 scaling format as described in the PROFdrive® standard. After selecting this profile, use parameters **No. 6310–6313** to change the scaling if desired.

NOTICE

PROFdrive® AC 1 profile is available to be used regardless of the used fieldbus protocol. However, it is the recommended option when using the PROFINET® protocol.

NOTICE

PROFINET® and PROFdrive® are registered trademarks of the PROFIBUS Nutzerorganisation e.V. (PNO).

2.2.3.1 Control Word Description

The following table describes the function of each bit in the fieldbus control word, when using PROFdrive® Application Class 1 profile.

Bit	Value	Significance	Comments
0	0	Off	Drive cannot operate.

Application Guide

Bit	Value	Significance	Comments
			A running drive is stopped with a ramp to zero speed. A resettable Switching On Inhibited state is reset.
	1	On	Drive is ready to operate.
1	0	Coast Stop	Drive coasts to a stop.
	1	No Coast Stop	The coast request is inactive. The drive can be started.
2	0	Quick Stop	Drive stops with the Quick Stop function.
	1	No Quick Stop	The Quick Stop request is inactive. The drive can be set ON again.
3	0	No Start	The drive stops operating and coast stop.
	1	Start	The drive starts to operate on the rising edge of this signal.
4	0	Disable Ramp Generator	The output of the speed ramp generator is forced to zero.
	1	Enable Ramp Generator	The output of the speed ramp can operate according to the speed reference.
5	0	Freeze Speed Reference	The speed reference (input of the ramp generator) is frozen to its latest value.
	1	Unfreeze Speed Reference	The speed reference can be changed freely.
6	0	Disable Reference	The speed reference (ramp generator input) is forced to zero.
	1	Enable Reference	The speed reference can be changed freely.
7	0	Event Reset Inactive	The rising edge of this signal will reset events (warnings, faults, and so on), which do not have active triggering conditions. After a fault, the drive goes to a Switching On Inhibited state, which must be acknowledged with bit 0.
	1	Event Reset Active	
8	0	Inching 1 Off	The speed reference can be set freely. The drive may stop depending on the inching-settings and whether start is inactive.
	1	Inching 1 On	The drive may ramp to the Inching 1 preset reference according to the Inching feature's settings in group G2.15 .
9	0	Inching 2 Off	The speed reference can be set freely. The drive may stop depending on the inching-settings and whether start is inactive.
	1	Inching 2 On	The drive may ramp to the Inching 2 preset speed reference according to the Inching feature's settings in group G2.15 .
10	0	Deactivate Fieldbus Control	Ignores the current Process Data. Uses the previously processed data when this bit was previously true.
	1	Activate Fieldbus Control	Control via this interface is acknowledged and process data is read. Note: For most of the control word's commands to be acknowledged by the drive, fieldbus must also be the commanding control place. See options in group G2.8.1 .
11	0	No significance	
	1		
12	0	Fieldbus Digital Input 1 Inactive	Select the value CTW B12 for any Input parameter to utilize this signal for the activation of a desired function.
	1	Fieldbus Digital Input 1 Active	
13	0	Fieldbus Digital Input 2 Inactive	Select the value CTW B13 for any Input parameter to utilize this signal for the activation of a desired function.

Bit	Value	Significance	Comments
	1	Fieldbus Digital Input 2 Active	
14	0	Fieldbus Digital Input 3 Inactive	Select the value CTW B14 for any Input parameter to utilize this signal for the activation of a desired function.
	1	Fieldbus Digital Input 3 Active	
15	0	Fieldbus Digital Input 4 Inactive	Select the value CTW B15 for any Input parameter to utilize this signal for the activation of a desired function.
	1	Fieldbus Digital Input 4 Active	

2.2.3.2 Status Word Description

The following table describes the function of each bit in the fieldbus status word, when using PROFIdrive® Application Class 1 profile.

Bit	Value	Significance	Comments
0	0	Not Ready To Switch On	
	1	Ready To Switch On	Motor control is ready, no active faults and switching on (control word bit 0) is allowed.
1	0	Not Ready To Be Started	The drive cannot be set running with a start command.
	1	Ready To Be Started	Control is switched on and a start command can be given.
2	0	Drive Stopped	The drive is not running.
	1	Drive Running	The drive is running.
3	0	Faults Inactive	All drive faults are inactive.
	1	Fault Active	One or more drive faults are active. Note: switching on is inhibited.
4	0	Coast Stop Active	The coast stop command is active.
	1	Coast Stop Not Active	The coast stop command is inactive.
5	0	Quick Stop Active	The quick stop command is active. Note: Switching on is inhibited. Note: The command can be given from fieldbus or IO.
	1	Quick Stop Not Active	The quick stop command is inactive. Note: a new start command is required.
6	0	Switching On Allowed	Nothing is inhibiting the drive from being switched on (control word bit 0 can be activated).
	1	Switching On Inhibited	Switching on is inhibited due to faults or quick stop. After faults have been acknowledged or the quick stop command removed, the Off-command must be given to reset this state.
7	0	Warnings Inactive	All drive warnings are inactive.
	1	Warning Active	One or more drive warnings are active
8	0	Speed Error Out of Tolerance Range	The actual speed differs from the speed reference more than 1% of motor nominal speed.
	1	Speed Error Within Tolerance Range	The actual speed differs from the speed reference less than 1% of motor nominal speed.
9	0	Fieldbus Control Inactive	None of the drive's basic command functions are affected by fieldbus commands.
	1	Fieldbus Control Active	Fieldbus is the active control place or configured as part of the

Bit	Value	Significance	Comments
			Advanced Control Place.
10	0	Speed Not Reached	The actual speed is below the comparison value set in limit supervision 1 feature (No. 5253).
	1	Speed Reached	The actual speed is above the comparison value set in limit supervision 1 feature (No. 5253).
11	0	No significance	
	1	No significance	
15			

2.2.3.3 The Profile States

The following figure presents the various states and transitions when using this profile. More information about using PROFINET® is available in the associated PROFINET® guide.

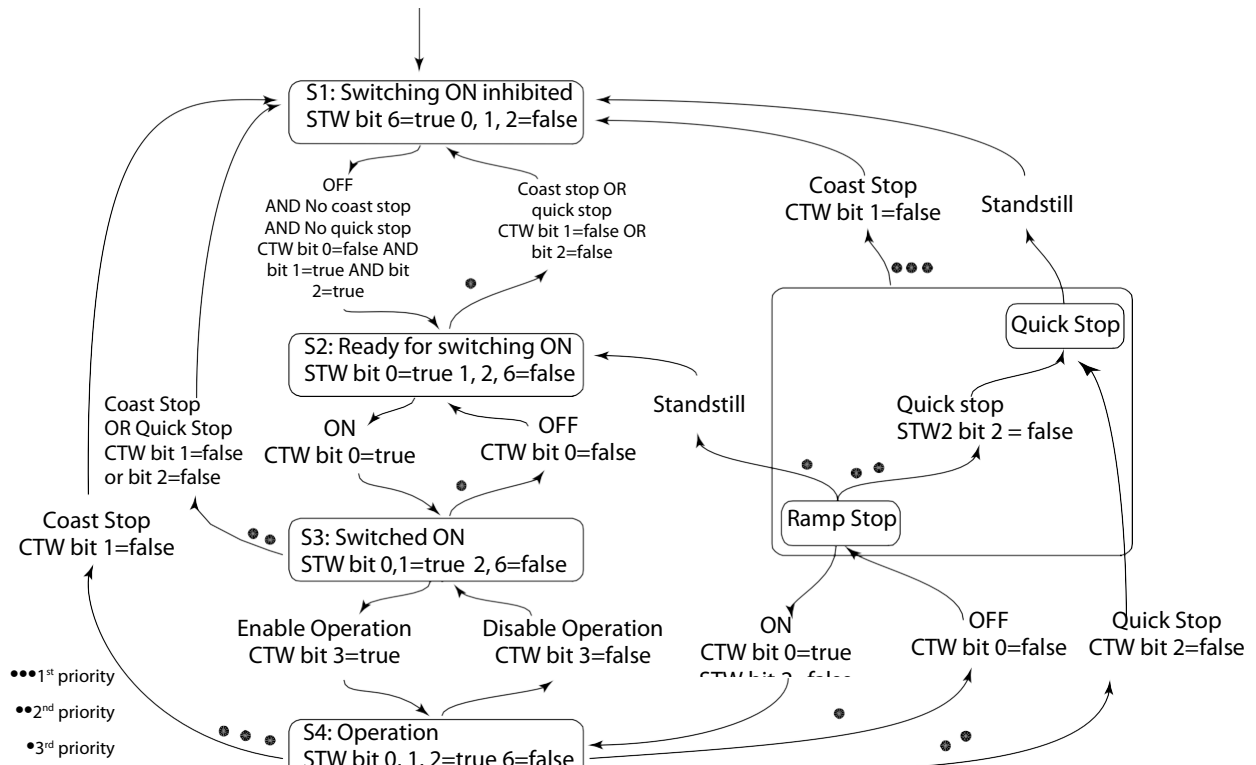

Figure 2: PROFdrive® profile state machine.

2.2.4 CiA-402 Velocity Mode Profile

The EtherCAT® CiA-402 velocity mode is implemented according to the CiA 402 standard and state machine diagram.

When this profile is selected, the drive uses the FB PCD Speed Reference (**No. 1345**) as the input signal. After selecting this profile, the parameters **No. 6310 and 6311** are used to limit the fieldbus speed reference.

NOTICE

CiA-402 Velocity Mode profile is available to be used regardless of the used fieldbus protocol. However, it is the recommended option when using the EtherCAT® protocol.

NOTICE

EtherCAT® is a registered trademark of EtherCAT Technology Group (ETG).

2.2.4.1 Control Word Description

The following table describes the function of each bit in the fieldbus control word, when using CiA-402 Velocity Mode profile.

Bit	Value	Significance	Comments
0	0	Switch Off	Drive cannot operate. A running drive is stopped with a ramp to zero speed.
	1	Switch On	Drive is ready to operate (start running).
1	0	Voltage Disable (Coast Stop)	Voltage is disabled. A running drive coasts to a stop.
	1	Voltage Enable (No Coast Stop)	Voltage is enabled. The drive can be switched on.
2	0	Quick Stop	Drive stops with the Quick Stop function.
	1	No Quick Stop	The Quick Stop request is inactive. The drive can be switched on.
3	0	Operation Disable (No Start)	The drive stops operating and stops with ramp.
	1	Operation Enable (Start)	The drive starts running on the rising edge of this signal.
4	0	Disable Ramp Generator	The output of the speed ramp generator is forced to zero.
	1	Enable Ramp Generator	The output of the speed ramp can operate according to the speed reference.
5	0	Freeze Speed Reference	The speed reference (input of the ramp generator) is frozen to its latest value.
	1	Unfreeze Speed Reference	The speed reference can be changed freely.
6	0	Disable Reference	The speed reference (ramp generator input) is forced to zero.
	1	Enable Reference	The speed reference can be changed freely.
7	0	Event Reset Inactive	The rising edge of this signal will reset events (warnings, faults, and so on), which do not have active triggering conditions.
	1	Event Reset Active	
8	0	No Ramp to Zero (No Halt)	Drive is ready to operate. Note! Operation identical to bit 6
	1	Ramp to Zero (Halt)	A running drive is ramped to zero speed. Note! Operation identical to bit 6
9	0	No significance	
	1		
10	0	Deactivate Fieldbus Control	Ignores the current Process Data. Uses the previously processed data when this bit was previously true.
	1	Activate Fieldbus Control	Control via this interface is acknowledged and process data is read. Note: For most of the control word's commands to be acknowledged by the drive, fieldbus must also be the commanding control place. See options in group G2.8.1 .

Bit	Value	Significance	Comments
11	0	No significance	
	1		
12	0	Fieldbus Digital Input 1 Inactive	Select the value CTW B12 for any Input parameter to utilize this signal for the activation of a desired function.
	1	Fieldbus Digital Input 1 Active	
13	0	Fieldbus Digital Input 2 Inactive	Select the value CTW B13 for any Input parameter to utilize this signal for the activation of a desired function.
	1	Fieldbus Digital Input 2 Active	
14	0	Fieldbus Digital Input 3 Inactive	Select the value CTW B14 for any Input parameter to utilize this signal for the activation of a desired function.
	1	Fieldbus Digital Input 3 Active	
15	0	Fieldbus Digital Input 4 Inactive	Select the value CTW B15 for any Input parameter to utilize this signal for the activation of a desired function.
	1	Fieldbus Digital Input 4 Active	

2.2.4.2 Status Word Description

The following table describes the function of each bit in the fieldbus status word, when using CiA-402 Velocity Mode profile.

Bit	Value	Significance	Comments
0	0	Not Ready To Switch On	
	1	Ready To Switch On	Switching on is allowed (control word bits 1 and 2 are true).
1	0	Not Switched On	The drive cannot be set running with a start command.
	1	Switched On	Control is switched on and a start command can be given (control word bits 0, 1 and 2 are true and no faults).
2	0	Operation Disabled	The drive is not operating (running).
	1	Operation Enabled	The drive is operating (running).
3	0	Faults Inactive	All drive faults are inactive.
	1	Fault Active	One or more drive faults are active. Note: Drive is not ready to switch on.
4	0	Voltage Disabled	Motor Control not ready. Motor Control Status Word (No. 1714) bit 0 = false.
	1	Voltage Enabled	Motor Control ready. Motor Control Status Word (No. 1714) bit 0 = true.
5	0	Quick Stop Active	The quick stop command is active.
	1	Quick Stop Not Active	The quick stop command is inactive.
6	0	Switching On Allowed	Nothing is inhibiting the drive from being switched on.
	1	Switching On Inhibited	Switching on is inhibited due to fault or quick stop.
7	0	Warnings Inactive	All drive warnings are inactive.
	1	Warning Active	One or more drive warnings are active
8	0	No significance	
	1	No significance	
9	0	Fieldbus Control Inactive	None of the drive's basic command functions are affected by fieldbus

Bit	Value	Significance	Comments
			commands.
	1	Fieldbus Control Active	Fieldbus is the active control place or configured as part of the Advanced Control Place.
10	0	Target (Speed) Not Reached	The actual speed differs from the speed reference by a given tolerance.
	1	Target (Speed) Reached	The actual speed matches the speed reference within a given tolerance.
11	0	Limiter inactive	All limiters (regulators) are inactive.
	1	Limiter active	One or more limiter (regulator) is actively limiting the drive current, torque and so on. See No. 1715 for further details.
12	0	No significance	
-	1	No significance	
15			

2.2.4.3 The Profile States

The CiA-402 Velocity Mode profile uses a state machine. The state machine and the transitions are described in Figure 3. For more information please refer to the EtherCAT® operating guide

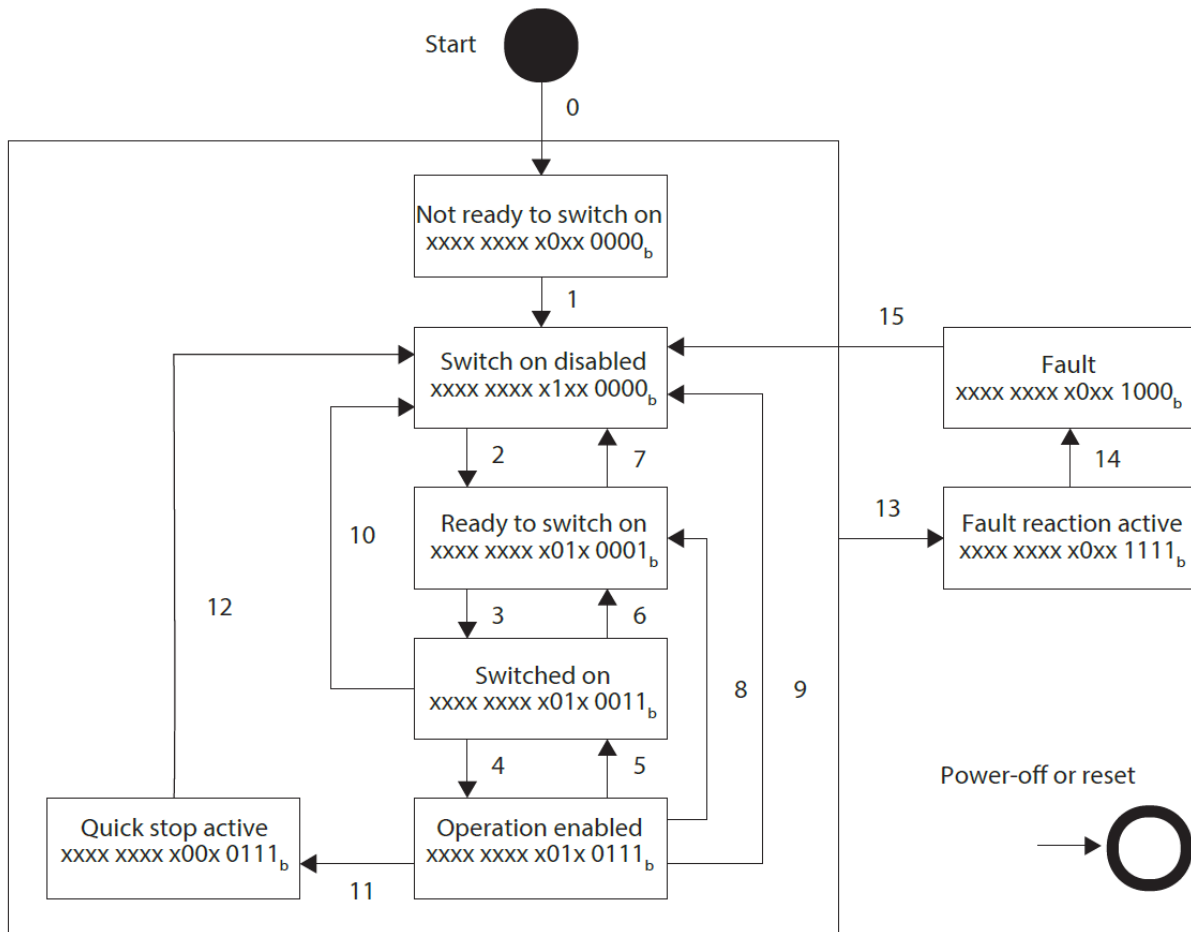

Figure 3: General State Diagram for CiA-402 Velocity Mode.

Application Guide

Command	Control Word Bits					Transitions
	Bit 7	Bit 3	Bit 2	Bit 1	Bit 0	
Shutdown	Automatic transition after drive status is ready.	None	Start Interlock			
2, 6	Shutdown command	None	Drive Off			
3	Shutdown command	None	Drive Ready			
4	Enable operation command	None	Running Disabled Reference 0.0 rpm			
5	Disable operation command	Drive function ramp stop	Stopping			
7	Disable voltage or quick stop command	None	Quick Stop/Drive Off			
8	Shutdown command	Ramp stop	Stopping			
9, 12	Disable voltage command	Coast stop	Start Interlock			
10	Disable voltage command	None	Start Interlock			
11	Quick stop command	Quick stop	Quick Stop			
13	Fault signal	Go to fault state	Fault! Start Blocked			
14	Automatic transition	None	-			
15	Fault reset command	Reset currently active fault. The fault trigger must be solved before the fault can be reset.	-			

Transition	Event(s)	Actions(s)	Drive State
0	Automatic transition after power-on or reset	Self-initialization is performed	-
1	Automatic transition after drive status is ready.	None	Start Interlock
2, 6	Shutdown command	None	Drive Off
3	Shutdown command	None	Drive Ready
4	Enable operation command	None	Running Disabled Reference 0.0 rpm
5	Disable operation command	Drive function ramp stop	Stopping
7	Disable voltage or quick stop	None	Quick Stop/Drive Off

Application Guide

Transition	Event(s)	Actions(s)	Drive State
	command		
8	Shutdown command	Ramp stop	Stopping
9, 12	Disable voltage command	Coast stop	Start Interlock
10	Disable voltage command	None	Start Interlock
11	Quick stop command	Quick stop	Quick Stop
13	Fault signal	Go to fault state	Fault! Start Blocked
14	Automatic transition	None	-
15	Fault reset command	Reset currently active fault. The fault trigger must be solved before the fault can be reset.	-

3 User Interfaces and How to Configure

3.1 Overview of User Interfaces

To interact with a Danfoss iC7 Series drive, use either the control panel as a simple and direct interface, or the software tool MyDrive® Insight for more advanced interaction with the drive. The control panel can be mounted directly on the drive, or close to the drive by using a control panel mounting kit.

With MyDrive® Insight the drive can be accessed from a remote place, if the infrastructure is in place and the network provides the required access rights.

3.2 Control Panel

The chapter provides an overview about the different control panel options, the related elements, important features and functionalities, and quick guidance on how to use the control panel.

3.2.1 iC7 Control Panel Options

The iC7 series offers a broad range of interfaces which suit different connectivity requirements to support wireless regulations.

The iC7 Series offers the following 2 different control panel options. Refer to the relevant Design Guide for information on which control panels are available to your product.

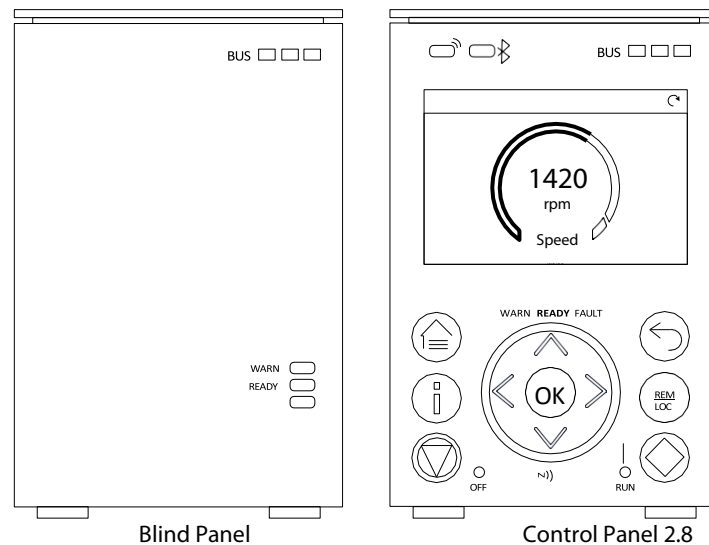

Figure 4: Control Panel options.

- **Blind Panel OPX00:** This panel shows the basic status of the drive and fieldbus indicators. The panel is typically used when only limited interaction with the drive is required after installation and commissioning, or when the drives are controlled by fieldbus.
- **Control Panel 2.8 OPX20:** This panel is the standard user interface, and used when frequent interaction with the drive is required. The panel enables easy setup of the drive via parameters, monitoring the drive status, and also shows event notifications.

Control Panel 2.8 OPX20 has the following features:

- 2.8" monochromatic user interface with a display resolution of 240 x 160 pixels.
- Visual LEDs to illustrate drive status and fieldbus communication.

- Halo indicator with 3 colors to illustrate drive status at a glance.
- A display which can be customized to show required or essential information.
- Buttons to control the drive locally, including a toggle button to easily switch between local and remote control.
- Parameter widgets which support alphanumeric and special characters, integers, floating points, date time formats, selection lists, and commands to configure application data.
- Help texts to support the operating.

3.2.2 Control Panel Elements

The control panel provides an interface for configuring and controlling the drive easily. The section describes the elements for all control panel options.

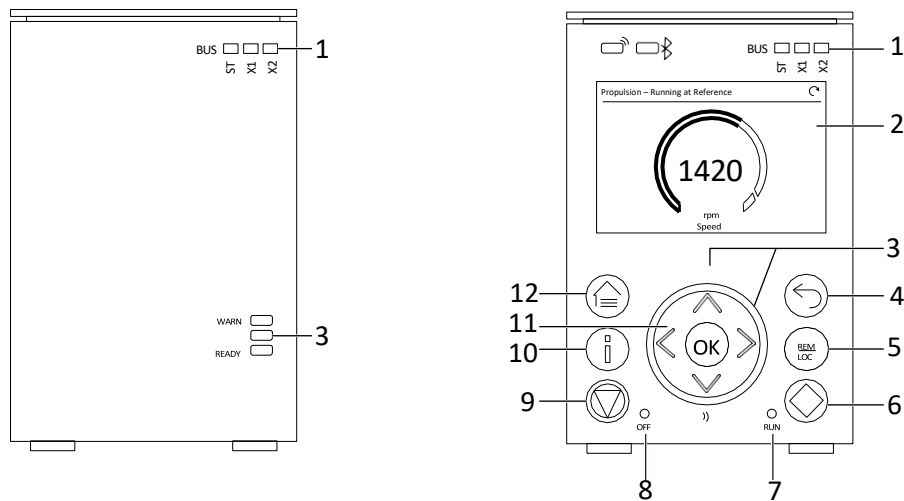

Figure 5: Panel elements.

Legend	Name of Element	Description
1	Fieldbus Indicators	<p>The LEDs indicate the status of the communication interface X1 and X2.</p> <ul style="list-style-type: none"> • [ST] <ul style="list-style-type: none"> ○ Green blinking LED indicates that the communication interfaces are in normal operating state. ○ Red blinking LED indicates that an error has occurred and communication is not possible. • [X1] <ul style="list-style-type: none"> ○ Green blinking LED indicates data exchange on communication interface X1. ○ Red blinking LED indicates an error during data exchange on communication interface X1. • [X2] <ul style="list-style-type: none"> ○ Green blinking LED indicates data exchange on communication interface X2. ○ Red blinking LED indicates an error during data exchange on communication interface X2.
2	Display	Enables access to content and settings. The display provides detailed information about the status of the drive.

Legend	Name of Element	Description
3	Drive Status Indicators	<p>The LEDs indicate the status of the drive.</p> <ul style="list-style-type: none"> • [WARN] <ul style="list-style-type: none"> ○ When this text is lit in yellow, it indicates a warning-level event. • [READY] <ul style="list-style-type: none"> ○ When this text is lit in white, it indicates that the drive is ready for operation. ○ When this text is blinking white (1 Hz), it indicates that the drive is powered on but is not ready. • [FAULT] <ul style="list-style-type: none"> ○ When this text is lit in red, it indicates a fault. <p>The status of the drive is also indicated by the Halo, which has the same color indicators as the drive status texts on the control panel.</p>
4	Back button	Navigates to the previously viewed screen or a menu level above the current menu.
5	REM/LOC	Toggles the drive between remote and local operation.
6	Run button	Starts the operation of the drive.
7	RUN LED	<p>The indicator has the following states:</p> <ul style="list-style-type: none"> • On: Start command is applied and the drive is modulating. • Off: The drive has stopped and the start command is not applied.
8	OFF LED	<p>The indicator has the following states:</p> <ul style="list-style-type: none"> • Steadily on: The indicator is in this state because of either of the following two reasons: <ul style="list-style-type: none"> ○ The drive is not modulating and is coasted. ○ The stop signal is applied, output is active, and the drive is ramping down until coast or restart. Ramp times, protections, and stopping functions prolong this state. • Flashes for 3 seconds: Indicates that the start command is initiated, but the drive is not able to start. • Off: The drive is in operation, a start signal is applied, and the output is active. This also includes ramping, running on reference, and AMA. <p>Note: When a fault has occurred in the drive, the LED is on though the start command is available. If there is a fault event, and the start command is disabled and reinitiated again, the Off LED blinks.</p>
10	Info button	Provides more detailed information about an event that has occurred in the drive. Pressing Info also shows a context sensitive help for parameters.
11	Arrow buttons	<ul style="list-style-type: none"> • Arrow buttons: Used to navigate within the different screens and menus. • [OK]: Primarily used to confirm selections and data in the control panel display.
12	Home/Menu button	Toggles between Home screen and the current parameter menu, to allow quick access to key status information during parameter setup.

3.2.3 Control Panel Basic Configurations

The basic configurations of the control panel include:

- A readout of the status of the motor and the drive, including warnings and faults.
- Navigable menus, where the parameter settings of the drive can be viewed and changed.

3.2.3.1 Starting the Drive and Control Panel Display

While the drive is powering up until it is ready to operate, the control panel display shows the following:

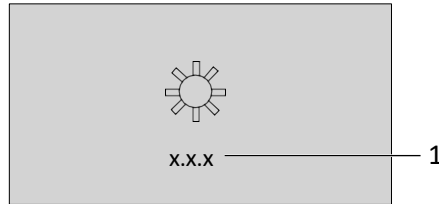

Figure 6: Control Panel display on startup.

Legend	Description
1	Panel software number

NOTICE

When the drive is started, it takes 25–30 s for the drive to be in ready state and for the control panel display to change to the Home screen (default).

3.2.3.2 Understanding Readout Screens

When the drive is in ready state, the control panel display shows the Home screen. By default, the Home screen is shown as follows, however the Home screen can be customized.

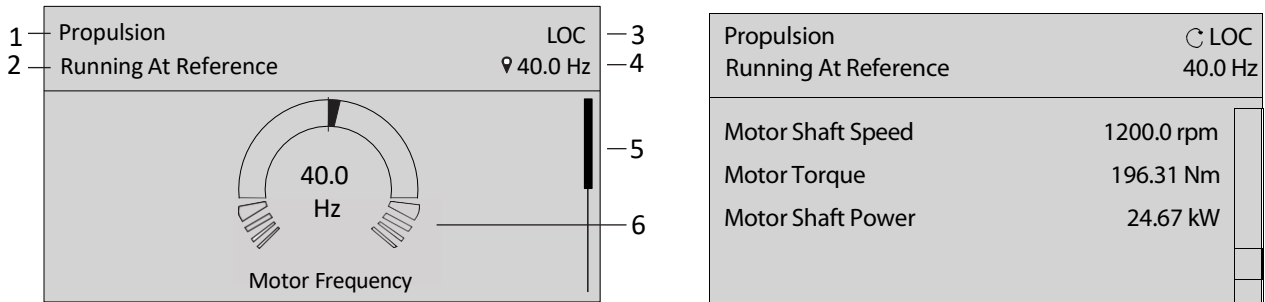

Figure 7: Home screen (Donut View vs. Line view).

Legend	Description
1	The name of the application software
2	The status of the drive (check the following table)
3	The current control of the drive. REM indicates remote control and LOC indicates local control. The arrow shows the direction of the motor.
4	The setpoint of the selected operation mode. The local setpoint can only be changed when the drive is in local control.
5	The scroll bar. The scroll bar indicates whether the screen is in the upper Readout Screen 1 or lower Readout Screen 2 position, when in the menu structure or parameters
6	The readout value as a donut infographic view. It is possible to show only a single readout in a donut view. When more than 1 readout is configured, the screen changes to a line view. A minimum of 2 and a maximum of 5 readouts are shown in the line view.

The status line of the control panel shows the status of the drive. The status line texts are dynamically generated, based on the configuration of the system. The following are some examples of basic operation:

Drive Status	Description
Drive Ready	The drive is powered and ready to start.
Running at Reference	The drive is running at the selected reference.
Running at Standstill	The drive is running with 0 reference.
Stopping	The drive is running towards stop.
Stopped	The drive is stopped due to an active stop command.
Coasted	The drive is coasting due to an active coast command.
Quick Stop	The drive is stopped due to an active quick stop command.
Start Interlock	The drive is stopped with an active start command. To restart, the start command must be removed and given again.
Start Inhibited	The drive is in a state that is preventing start. All start commands are ignored.
Safe Torque Off (STO)	The drive is coasting due to an active STO command.
Inching	The drive is inching or jogging.
Running/Stopping/Inching with: <ul style="list-style-type: none"> • Power Limit • Undervoltage Limit • Overvoltage Limit • Torque Limit • Current Limit • Speed Limit 	The drive is running, stopping, or inching, and has exceeded the limit that is shown. For example, <i>Running - Power Limit</i> . Some possible limits are listed in the cell on the left. See also the preceding image.
AMA Ready	Advanced Motor Adaptation is activated and is waiting for the start command.
AMA in Progress	Advanced Motor Adaptation is running, measuring motor data.
AMA Finished	Advanced Motor Adaptation is finished. To restart the drive, remove and then reapply the start command.

Press the down arrow on the control panel when in Readout Screen 1, and the control panel screen navigates to Readout Screen 2. As a factory default setting, the control panel shows 3 readout values, as shown in the preceding image.

3.2.3.3 Changing the Content of the Readout Screens

This chapter outlines an example procedure for changing or customizing the content of Readout Screen 1. The same procedure is applicable for Readout Screen 2.

1. To start the screen content editing mode, press [OK] for a minimum of 5 seconds. The screen changes as shown in the following image.

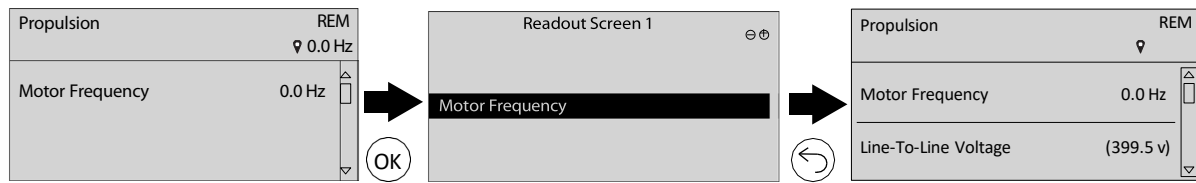

Figure 8: Typical Readout Screen.

- Remove an existing readout by pressing the up-arrow button on the control panel and navigating to the Remove readout button on the UI and pressing it.

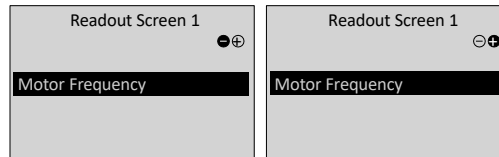

Figure 9: Add and remove readout buttons.

NOTICE

When the remove readout button is pressed, the last readout on the list is removed.

- Add a readout to the screen by navigating to the Add readout button on the UI and pressing it. To move between the Add readout and Remove readout buttons, press the left or right arrow buttons on the control panel.
- After pressing the Add readout button, select the readout to be added.

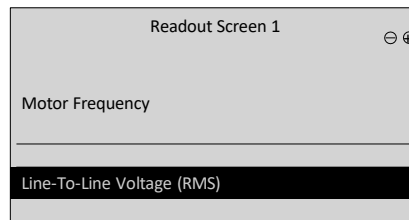

Figure 10: Updating the readout screen.

- Add more readouts by pressing the Add readout button and selecting a readout.
- After selecting the readouts to be added or removed from the list, press [OK].
- To exit the screen content editing mode, press the [Home] or [Back] button.

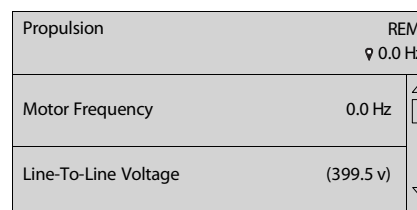

Figure 11: Updated readout screen.

NOTICE

The readout screens can also be adjusted using parameter group **5.2 Control Panel**. For more information, see Device Settings (Menu Index 5).

3.2.3.4 Adjusting Display Backlight and Contrast

When in Readout Screen 1 or Readout Screen 2, it is possible to adjust the backlight intensity and contrast of the display.

To adjust the display backlight and contrast settings, press the [Info] button and any of the arrow buttons of the control panel. The settings are shown on the screen:

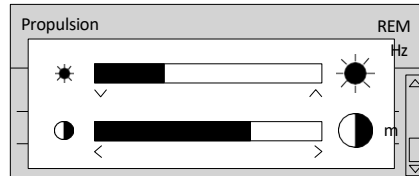

Figure 12: Intensity change of backlight and contrast.

- To change the intensity of the backlight, keep pressing the [Info] button along with either the up or down arrow buttons of the control panel.
- To change the contrast, keep pressing the [Info] button along with either the left or right arrow buttons of the control panel.

3.2.3.5 Parameter Group Screen and Overall Navigation

Pressing the [Home/Menu] button toggles between the readout screens and the parameter group screen. The content of the parameter group screen can vary depending on the current level of the parameter group. A typical parameter group screen is shown in the following image.

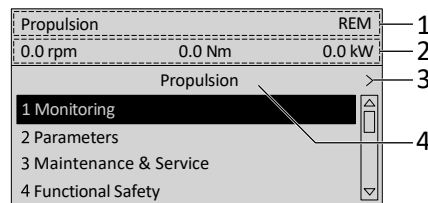

Figure 13: Parameter group screen.

Legend	Description
1	Name and control state of the drive.
2	The menu readout header. It shows the following signals from left to right: Motor Shaft Speed (rpm), Motor Torque (Nm) and Motor Power (kW).
3	Previous and Next arrow icons. Press the icons to navigate 1 level above or below in the parameter group structure. When the Previous or Next arrow is not shown, it indicates that the view is at the top or bottom of the menu structure, respectively.
4	Name of the application software that is active in the drive.

Basic navigation techniques

To navigate through and within the different parameter groups, use the navigation buttons of the control panel.

- To navigate to different parameter groups, press the up or down arrows of the control panel.
- To navigate to parameter subgroups or parameters within a parameter group, press the left or right arrows of the control panel.

- To navigate to a higher level in the parameter/parameter group screens press the Back button, and to navigate to a lower level press the OK button.

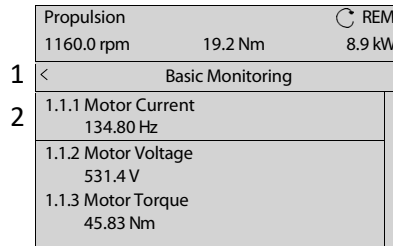

Figure 14: Parameter navigation.

Legend	Description
1	Previous button when in a parameter group.
2	When parameters are defined as readout only, the current value is shown below the parameter name. A black outline around the parameter without any highlighting indicates that the value of the parameter cannot be changed.

3.2.3.6 Changing the Selections of a Parameter

When a parameter has selections, the parameter index and name are highlighted in black. The example parameter in this procedure is **P2.1.1 Motor Type**.

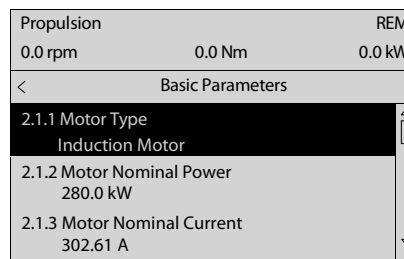

Figure 15: Changing selection in a Parameter.

- To view the selections of the parameter, press the right arrow button or [OK] on the control panel. The selections available for the parameter are shown on the screen.

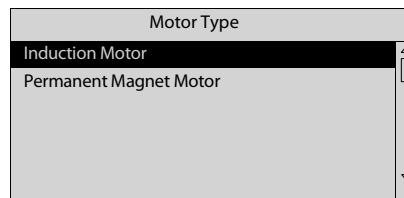

Figure 16: Selections for a Parameter.

- To browse through the selections, press the up or down arrow buttons.
- To select a selection, press [OK].

3.2.3.7 Changing a Parameter Value

The example parameter in this procedure is **P2.1.2 Motor Nominal Power**.

1. Go to parameter **2.1.2 Motor Nominal Power** and press [OK].
2. To go to the values before or after the decimals, use the left and right arrow buttons. A black highlight on the digit indicates the location where the cursor is active.
3. To increase or decrease the value, press the up and down arrow buttons.
4. Confirm the changes by pressing [OK].

The following illustration shows the process of changing the value of a parameter.

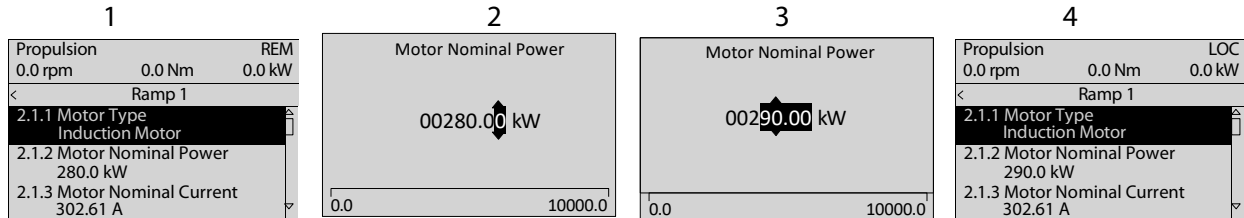

Figure 17: Changing the value of a parameter.

3.2.3.8 Locking the Control Panel Display

To avoid unintended interaction via the control panel, the control panel display can be locked.

To lock the control panel, press the [Back] button for 3 s. After 3 s, the following screen is shown.

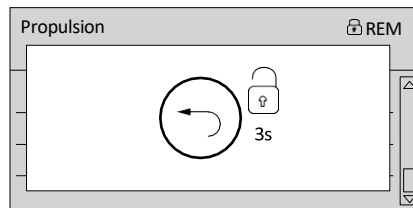

Figure 18: Control Panel lock screen.

When the control panel is locked, pressing the control panel buttons has no effect.

To unlock the control panel, press the [Back] button for 3 s.

3.2.4 Control Panel Shortcuts

The following table lists shortcuts in navigating in the control panel.

Action	Precondition	Buttons	Activation Time
Fast scroll	When in a menu or list of selections	Up and down arrows	1 s to activate
Factory reset		Home + Back + down arrow	3 s to activate
Keypad lock		Back	3 s to activate or deactivate
Reference set point editing	Home screen is active and LOC mode is active	[OK]	Single press
Editing Home screen readouts	Home screen active	[OK]	5 s to activate
Editing the Menu Readout header	Any menu is active	[OK]	5 s to activate
Show active events	Home screen is active	Info	Single press
Adjusting screen contrast and	Home screen is active	Info + arrows	Continuous simultaneous

Action	Precondition	Buttons	Activation Time
brightness			press

3.3 MyDrive® Insight

MyDrive® Insight is a platform-independent software tool that supports the commissioning, engineering, and monitoring of the iC7 series. Some of the key features include:

- Fast and easy configuration and commissioning.
- Monitor the drives as part of daily operations or any others.
- Collect data and information for troubleshooting, maintenance, and service.
- Discovery and access to multiple drives in a network.
- Intuitive user interface.
- Notifications and visualizations on real-time information and events about the drive.
- PC control to perform operations such as starting or stopping the drive, set references, set direction, reset, and coast of the drive.
- Perform updates on single or multiple drives.
- Backup and restore of parameter settings.
- Data logging and analyzing for troubleshooting.

NOTICE

The section is documented for MyDrive® Insight version 2.8.0 or above. Make sure to uninstall lower versions of MyDrive® Insight from the workstation to utilize the latest MyDrive® Insight functions.

NOTICE

The section MyDrive® Insight in the application guide covers basic information such as getting started with MyDrive® Insight, accessing and viewing or changing the parameters, and PC control to operate the drive using MyDrive® Insight. For further information on the different MyDrive® screens, integrated help within MyDrive® Insight will be available in future releases.

3.3.1 Getting Started with MyDrive® Insight

As a prerequisite, ensure that MyDrive® Insight is installed on the device (PC or laptop). MyDrive® Insight can be downloaded and installed from MyDrive® Suite, available here:

<https://suite.mydrive.danfoss.com/>.

Procedure:

1. To establish a point-to-point connection between the drive and the device, use the communication interface X0 and the RJ45 Ethernet port on the device by using a standard Ethernet cable.

If the device does not have an RJ45 Ethernet port or it is already in use, then a conventional adapter from USB-C to RJ45 can be used. To connect several drives at the same time, use an Ethernet switch between the PC and the control unit.

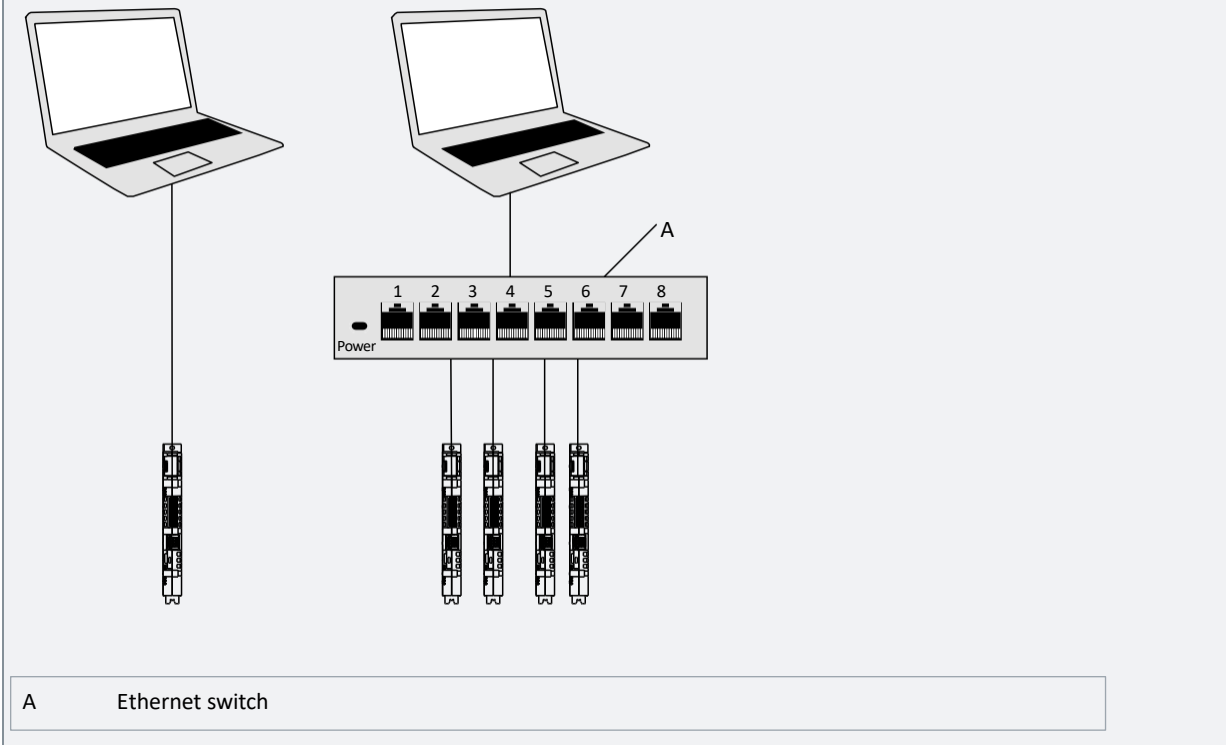

Figure 19: Connection to the PC.

- When the drive is powered up and in Ready state, open MyDrive® Insight on the device and the drive is recognized.

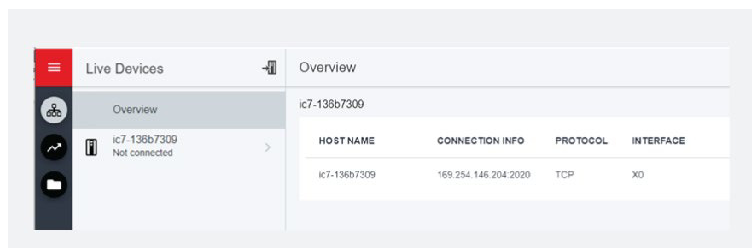

Figure 20: Confirm connection.

- Once the connection is established, the drive is marked with a connection symbol (green color) in MyDrive® Insight, as shown.

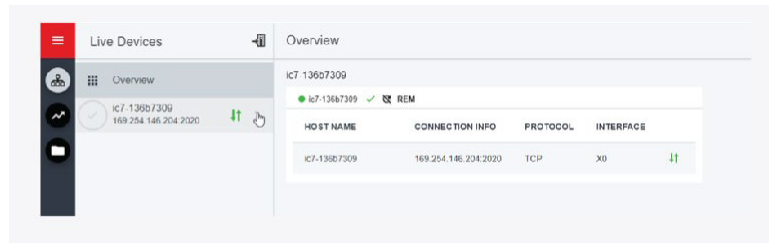

Figure 21: Establish connection.

- To establish or confirm the connection, click the arrow button.
- Select the required interaction for the drive. In this example, the Device Info screen is shown.

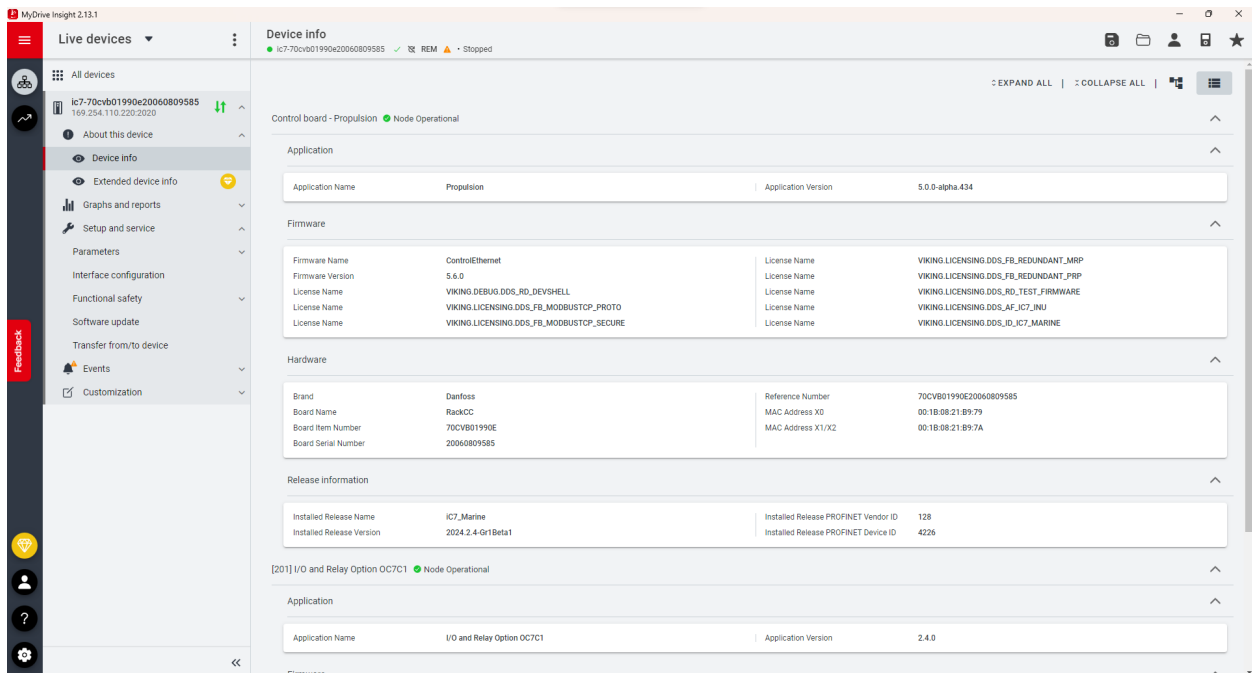

Figure 22: Device info.

NOTICE

The application guide covers basic information such as accessing parameters and using the PC control in MyDrive® Insight.

3.3.2 Accessing Parameters and Understanding Parameter Screens in MyDrive® Insight

Viewing and Changing Parameters

- To access the parameters of the connected drive, click Setup and Service.
- Click Parameters → Live, as shown.

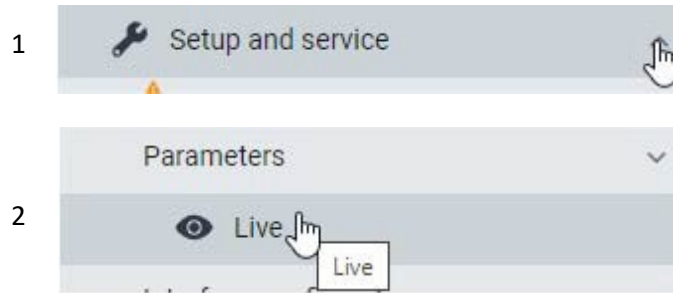

Figure 23: Setup and Service.

Parameter Screen Overview

The following is an overview of the Parameters (Live) screen in MyDrive® Insight.

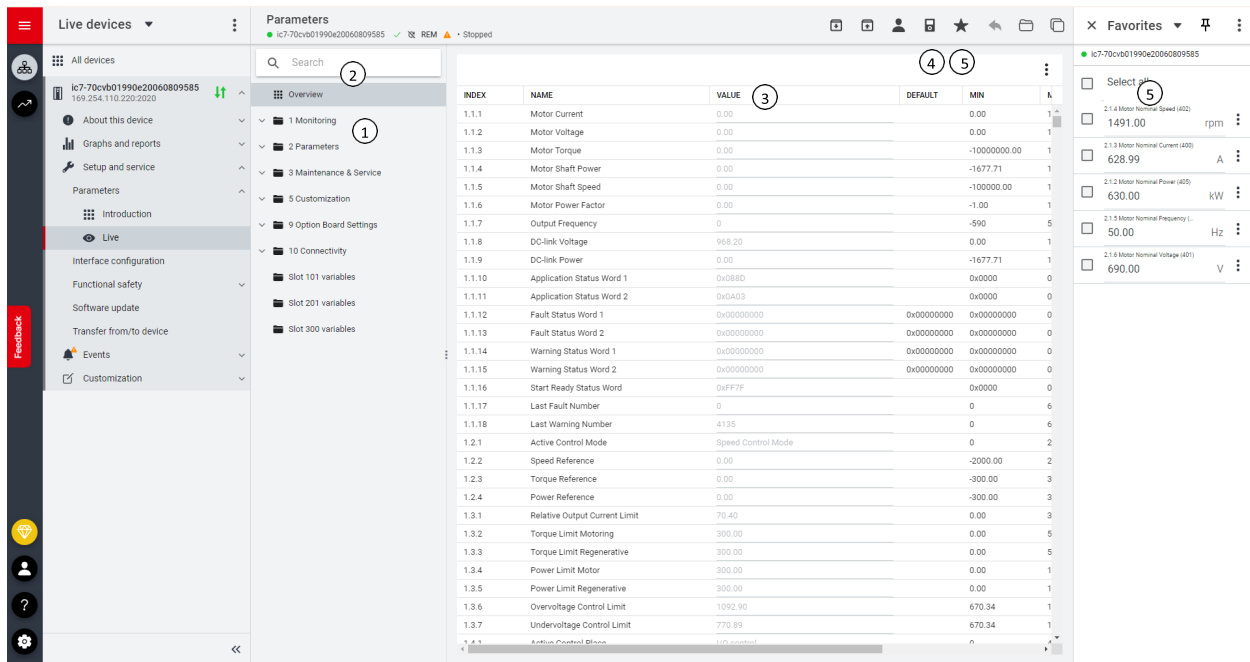

Figure 24: Parameter in the Live view.

Legend	Name	Description
1	Parameter group	Navigate through the different parameter groups in the drive.
2	Search field	Use the search function to find a specific parameter.
3	Value field	View and change a parameter value or selection. All the parameters for the drive are shown on the Live screen.
4	PC Control button	Switch to PC control to start or stop the drive using MyDrive® Insight.
5	Favorites	Select a parameter as a favorite by clicking the star in its row.

Navigate through different parameter groups

In the following picture, parameter group **2.3.2 Output Current Limit** is shown as an example.

INDEX	NAME	VALUE	DEFAULT	MIN	MAX	UNIT	NUMB...			
2.3.2.1	Output Current Limit	150.00	150.00	0.00	200.00	%	3190	?	☆	⋮
2.3.2.2	Current Limiter Kp	100.00	100.00	0.00	500.00	%	3193	?	☆	⋮
2.3.2.3	Current Limiter Ti	100.00	100.00	0.00	500.00	%	3194	?	☆	⋮
2.3.2.4	Current Limit Scaling Select	No Scaling	No Scaling	0	3		3191	?	☆	⋮
2.3.2.5	Current Limit Scaling Input	None	None	0	29999		3199	?	☆	⋮
2.3.2.6	Current Limit Failure Response	No response	No response	False	True		5169	?	☆	⋮
2.3.2.7	Current Limit Failure Preset	100.00	100.00	0.00	200.00	%	5170	?	☆	⋮

Figure 25: Parameter group.

1. Click the parameter group (1) from the Live pane.
2. Click the parameter subgroup (2).
3. Repeat step 2, until the right level of parameter subgroup (3) is reached to find the specific parameters (4).

NOTICE

When in a specific parameter subgroup, only parameters relevant to the parameter subgroup can be accessed.

Searching for a specific parameter

In the Search field, type the search term. The search returns all parameters that have the search term in the name, index, or number. The search applies to the selected parameter group. To search within all groups, select the "Overview" group first. In the following example, all parameters with the search term (1) "DC-link" in the name are listed in the search results (2).

INDEX	NAME	VALUE	DEFAULT	MIN	MAX	UNIT	NUMB...			
1.1.8	DC-link Voltage	968.03		0.00	1700.00	V	9044	?	☆	⋮
1.1.9	DC-link Power	0.00		-1677...	1677.71	kW	5117	?	☆	⋮
2.1.7	DC-link Nominal Voltage	975.81	0.00	0.00	1100.00	V	2834	?	☆	⋮
2.3.5.4.2	DC-link Voltage Droop Gain	0.00	0.00	0.00	10.00	%	2912	?	☆	⋮
2.3.5.4.3	DC-link Voltage Droop. Tc	0.050	0.050	0.000	1.000	s	5095	?	☆	⋮
2.6.3.1	Drive DC-link Voltage Output	None	None	0	29999		2311	?	☆	⋮
2.11.2.4	DC-link Voltage Measurement ...	0.00	0.00	-1.00	1.00	%	6535	?	☆	⋮
2.11.2.5	DC-link Voltage Measurement ...	0.00	0.00	-5.00	5.00	V	6534	?	☆	⋮

Figure 26: Parameter search.

Viewing and Changing Parameter Settings

When in a specific parameter group, or search results list, all parameters related to the parameter group or search are shown. Depending on the access type of the parameter, there is a possibility to view the parameter setting or change the current selection or value of the parameter.

In the following picture, parameters as the search result of the term “Motor” are shown as an example.

INDEX	NAME	VALUE	DEFAULT	MIN	MAX	UNIT	NUMBER	Help	Favorites
1.8.1	Motor Torque	0.00		-10000000.00	10000000.00	Nm	9009	?	☆
1.8.1.11	Relative Motor Torque	0.00		-300.00	300.00	%	1708	?	☆
1.8.1.12	Motor Shaft Power	0.00		-1677.71	1677.71	kW	9008	?	☆
1.8.1.13	Relative Motor Shaft Power	0.00		-300.00	300.00	%	1707	?	☆
1.8.1.14	Motor Electrical Power	0.00		-1677.71	1677.71	kW	9043	?	☆
1.8.1.15	Motor Thermal Load (ETR)	0.00		0.00	100.00	%	2951	?	☆
1.8.2.1	Motor Control Status Word	0x0001		0x0000	0xFFFF		1714	?	☆
1.8.2.2	Motor Control Ready Status Word	0xFFFF		0x0000	0xFFFF		1716	?	☆
1.8.2.3	Motor Regulator Status Word	0x0000		0x0000	0xFFFF		1715	?	☆
1.16.8	FB PCD Motor Torque Limit	0.00	0.00	0.00	300.00	%	3157	?	☆
1.16.10	FB PCD Motor Power Limit	0.00	0.00	0.00	300.00	%	3175	?	☆
1.16.19	FB PCD Master Motor Torque	0.00	0.00	-1000.00	1000.00	%	4506	?	☆
2.1.1	Motor Type	Induction Motor	Induction Motor	0	65535		407	?	☆
2.1.2	Motor Nominal Power	630.00	630.00	5.59	1677.71	kW	405	?	★
2.1.3	Motor Nominal Current	628.99	628.99	6.15	1845.00	A	400	?	★
2.1.4	Motor Nominal Speed	1491.00	1491.00	0.00	100000.00	rpm	402	?	★

Figure 27: Parameter overview.

Legend	Name	Description
1	Index	Based on the parameter group structure, the index defines the location of the parameter. The index is not used as a unique identifier of a parameter.
2	Name	Name of the parameter.
3	Status parameters	Provides the status or value of a parameter. The parameter value is shown in a light gray color and cannot be changed.
4	Selection parameters	To see all selections available for the parameter, click the value in the Value field.
5	Range parameters	The parameter value can be modified based on the ranges defined (maximum and minimum values).
6	Value	The current value of the parameter.
7	Default	The factory setting (default value) of the parameter.
8	Min and Max	When applicable, the minimum and maximum values of the parameter are shown in the Min and Max fields.
9	Unit	When applicable, the unit of the parameter is shown in the Unit field.
10	Number	The unique identifier for each parameter. The identifier is independent and decoupled from the parameter index values.
11	Help	Click the “?” button to see a description about the parameter. For more detailed descriptions, see 7 Parameter Descriptions.
12	Favorites (star)	Clicking the Favorites icon adds the parameter to Favorites.

3.3.3 PC Control to Operate the Drive Using MyDrive® Insight

To operate the drive using PC control, click the Control Panel button in MyDrive® Insight. The following illustration shows the different screens to operate the drive via MyDrive® Insight.

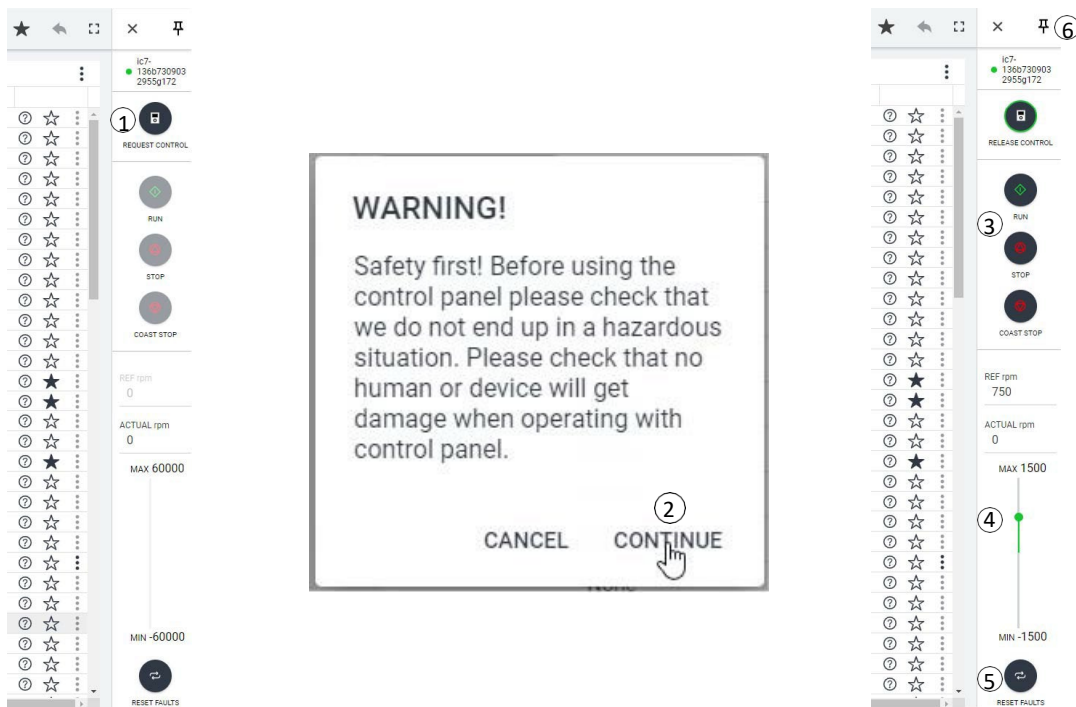

Figure 28: Operating the drive with MyDrive® Insight.

To access PC Control in MyDrive® Insight and operate the drive, perform the following:

1. Click REQUEST CONTROL button (1).
2. Click Continue (2) to confirm secure operational conditions while controlling the drive using MyDrive® Insight.
3. Use the START, STOP, STOP COAST buttons (3) to perform a drive operation. Use the slider (4) to increase or decrease the reference (speed, torque, or power).
4. To reset a drive in case of a fault, click RESET FAULTS (5).
5. For ease of access, click the Pin button (6) to make the control panel be constantly visible on the screen.

3.3.4 Datalogger

The datalogger in MyDrive® Insight enables the monitoring of signals and related information for the selected signals. To access the Datalogger feature, select the drive (1), then go to Graphs and Reports (2) → Datalogger (3).

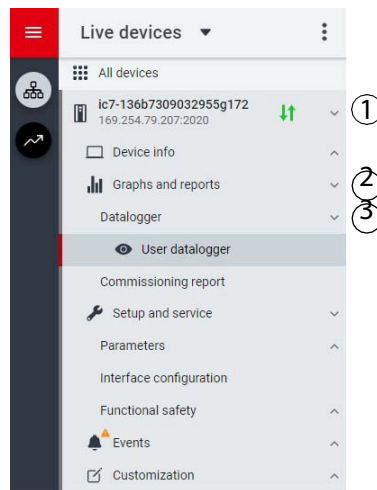

Figure 29: Navigation to the Datalogger.

The following image shows the Datalogger main controls.

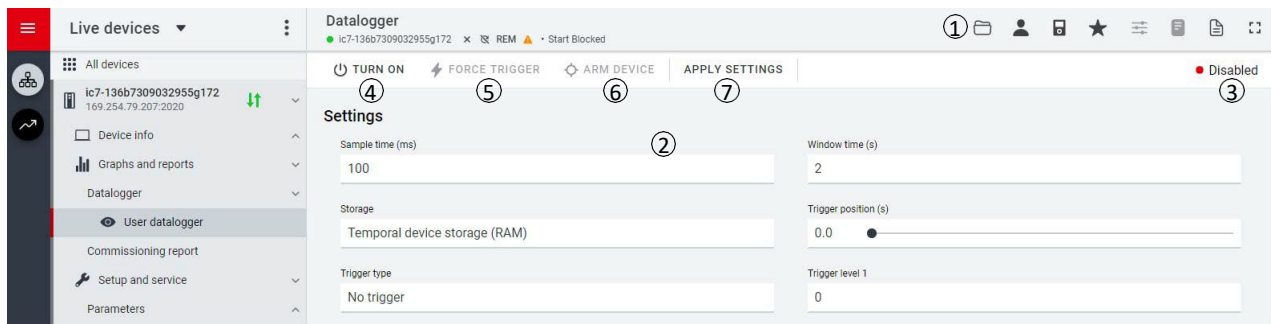

Figure 30: Datalogger screen.

Legend	Description
1	Opens the window to select available Datalogger files for viewing.
2	Shows the list of Datalogger settings.
3	Shows the Datalogger status.
4	Enables or disables Datalogger. When disabled, all Datalogger configuration settings are inactive. When enabled, Datalogger is active and operates based on the configuration settings.
5	Activates the force trigger. The 0 – 1 transition (rising edge) triggers Datalogger manually. This function is typically used with automatic triggers.
6	Arms Datalogger. The 0 – 1 transition (rising edge) readies Datalogger for triggering.
7	Applies any changed settings.

3.3.4.1 Configuring Datalogger

To configure the datalogger, the following are the 2 main steps:

- Configure the signals to be recorded using the datalogger.
- Configure the datalogger settings.

Procedure:

1. Open Datalogger.

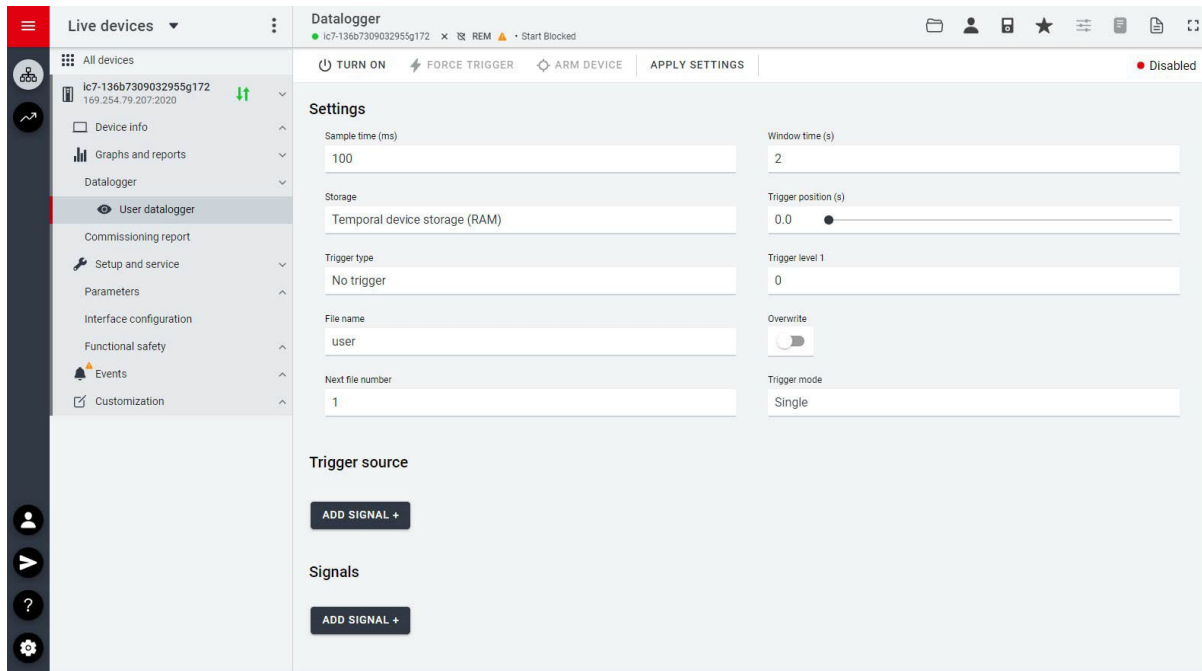
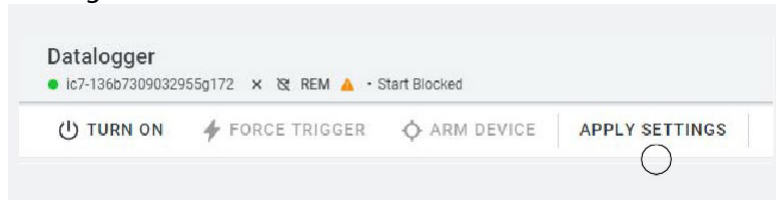

Figure 31: Datalogger settings.

Field name	Field Description
Sample time (ms)	Enter a sample time in ms. The actual sample time is dependent on the switching frequency. Fast sample rate settings result in data changing slowly in the resulting log.
Window time (s)	Defines the size of the capture window. Enter the window time in seconds. High sample rates and large capture times that result in large capture files may be rejected when the configuration is applied.
Storage	Select the location to which datalogger files are stored. Available selections are: <ul style="list-style-type: none"> • RAM: Settings are stored to the RAM of the drive. • Flash: Settings are stored to the flash of the drive. • SD card: Data is stored on the (optional) microSD card. The microSD cards supported are: SD, SDHC, or SDXC which must be formatted for the FAT32 file system. SDHC is the recommended type, as they are delivered preformatted to FAT32.

Field name	Field Description
Trigger position (s)	Adjust the slider to position the trigger. Setting the trigger position to 0 indicates the datalogger recording starts at the time of the trigger. Setting a negative value indicates that the datalogger recording starts after the trigger has occurred. Setting a positive value indicates that the datalogger recording starts before the trigger has occurred.
Trigger type	<p>Following are the trigger types:</p> <ul style="list-style-type: none"> • No trigger (manual trigger only) • Equal triggers when the value of the trigger source variable is equal to trigger level 1. • Not equal triggers when the value of the trigger source variable is not equal to trigger level 1. • Greater than triggers when the value of the trigger source variable is greater than trigger level 1. • Greater than or equal to triggers when the value of the trigger source variable is greater than or equal to trigger level 1. • Less than triggers when the value of the trigger source variable is less than trigger level 1. • Less than or equal to triggers when the value of the trigger source variable is less than or equal to trigger level 1. • Rising edge triggers when the value of the trigger source variable rises above trigger level 1. If the trigger source is already above trigger level 1, the trigger must first drop below the trigger level. • Falling edge triggers when the value of the trigger source variable falls below trigger level 1. If the trigger source is already below trigger level 1, the trigger must first rise above the trigger level.
Trigger level 1	Defines the trigger level associated with the defined trigger type. This level is used for all single-level trigger types. The entry in the field defines the lower trigger level for window trigger types, such as bounds and out of bounds.
File name	Name of the file for datalogger recording.
Overwrite	<p>Click the toggle button to turn the overwrite function on or off.</p> <ul style="list-style-type: none"> • On: Overwrite is enabled. A file number is not appended to the data log file. The datalogger overwrites a previous datalog file. • Off: Overwrite is disabled. A file number is appended to the log file. For each datalog, the datalog file is incremented and the previous datalog file is not overwritten.
Next file number	The number entered in this field is appended to the initial datalog file. Entry in the field is useful when data-logs are previously available in the drive. The number is auto-incremented with each datalog recording when the entry in Next file number is enabled.
Trigger mode	<p>Select 1 of the following trigger modes.</p> <ul style="list-style-type: none"> • Single trigger mode: After a datalog recording, the datalogger must be rearmed before another trigger is allowed. • Auto trigger mode: After a datalog recording, the datalogger automatically rearms and starts to accept triggers.
Trigger source	Click the Add signal button under the Trigger source heading. A Trigger source field appears. Click on the Trigger source field to select the signal source which is used for triggering the datalogger recording. The trigger source list opens in a new window:
Signals	<p>Click the Add signal button under the Signals heading. A Signal field appears. Click on the Signal field to select the signals that are logged. The signal list opens in a new window.</p> <p>Add more signals as necessary by clicking the <i>Add signal</i> button again.</p>

2. Click Apply Settings.



After the signal selection and the datalogger settings, the datalogger is ready to record the logs. To view a recorded datalog file, click the icon shown in the following figure.

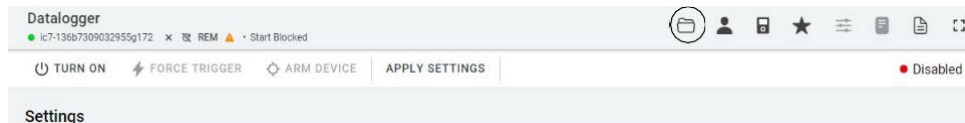

Figure 32: Datalogger view icon.

3.3.5 Backup and Restore

With the Backup feature in MyDrive® Insight the parameter settings of the drive can be stored into a new or existing project file, RAM, or Flash memory of the drive, or to an optional microSD card.

To utilize the microSD card as a storage device, the microSD card must be inserted in the slot on the interface module located behind the control panel, as shown in the following image.

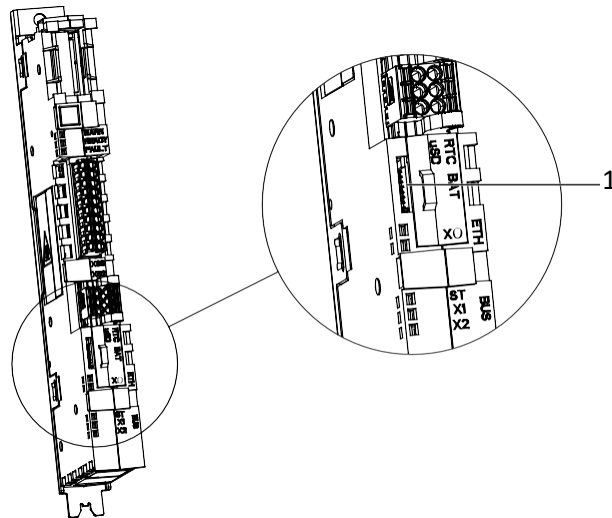

Figure 33: MicroSD card slot.

Legend	Description
1	MicroSD card slot

Following are the types of microSD card supported by the interface module, which must be formatted for the file system FAT32.

- Secure Digital (SD) card
- Secure Digital High Capacity (SDHC)
- Secure Digital Extended Capacity (SDXC)

NOTICE

It is recommended to use SDHC cards as they are preformatted to FAT32.

3.3.5.1 Backing up the Drive

Procedure

1. To back up the drive, select a drive, go to Setup & Services → Parameters → Live.
2. Click the icon as shown in the figure.

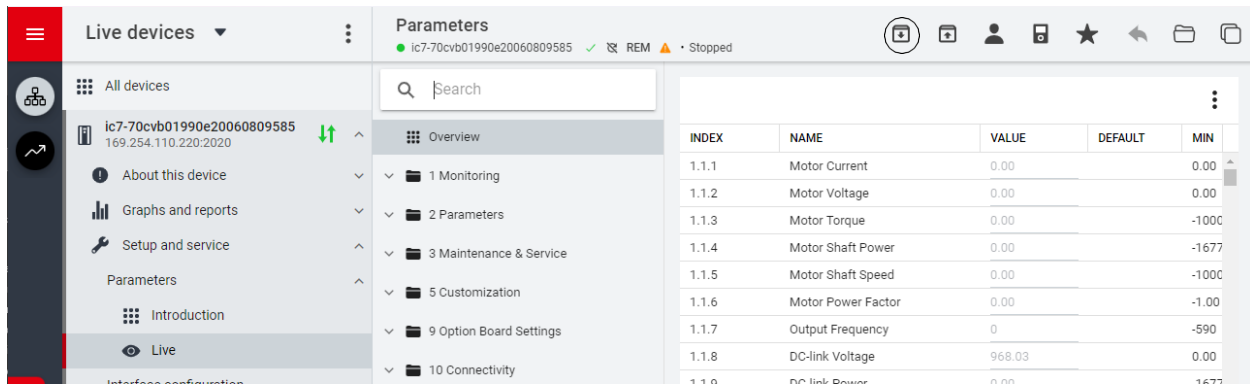

Figure 34: Backup icon.

- This opens a screen to select the backup destination. The destinations to back up are:
 - **Project:** The user can back up an existing project or a new project.
 - **Device file system:** The user can back up to 1 of the available memory devices of the drive.

3. Click Next.
4. If Project was selected, give the backup file a name and description.
If Device file system was selected, select where to save the backup. The selections are flash, RAM, or an (optional) microSD card. It is possible to specify a name for the backup file as well.
5. Click Backup to begin backup.

- Once backup is completed, a notification screen about it appears. If a project file was created, the backup is shown in the device menu under Parameters.

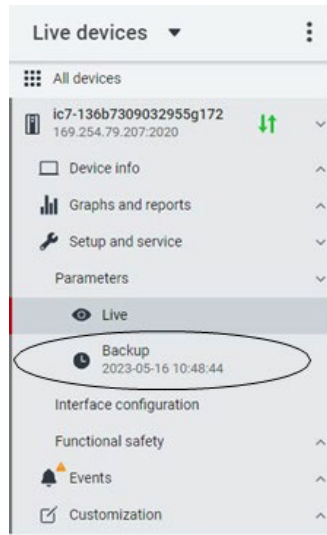

Figure 35: Backup file.

3.3.5.2 Restoring the data into the Drive

Procedure

1. To restore data to the drive, select a drive, go to Setup & Service → Parameters → Live.
2. Click the icon as shown in the image below.

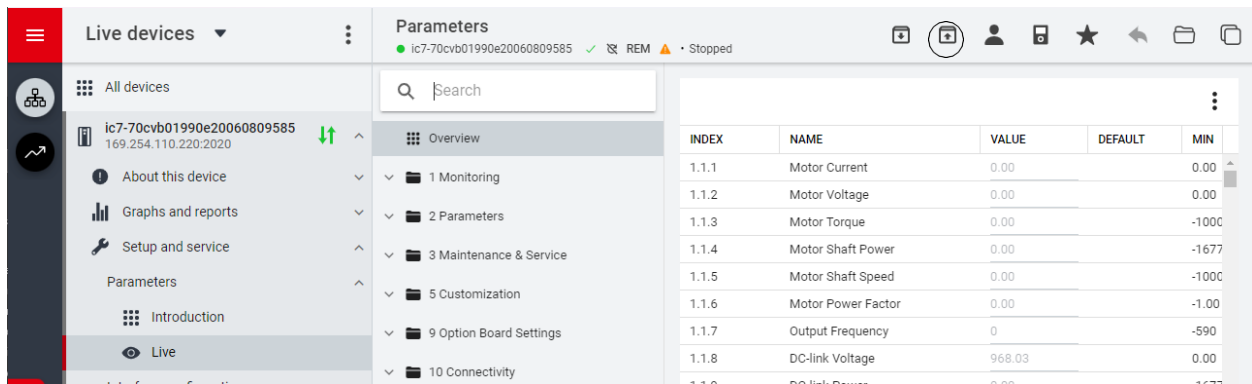

Figure 36: Restore data icon.

3. Select the source of the data which must be restored to the drive.

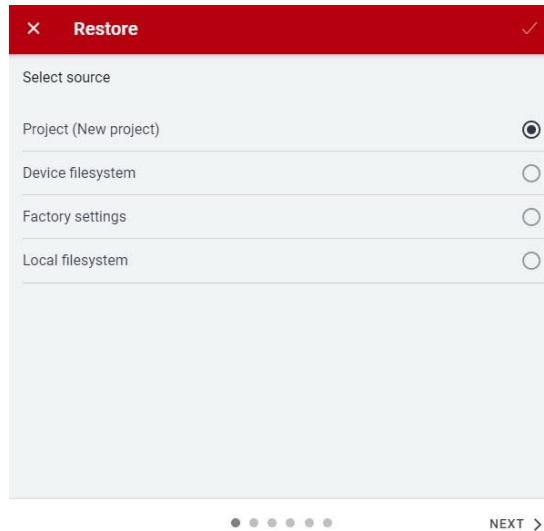

Figure 37: Source of data to be restored.

4. Click Next to select the backup source device and view the available backup files.
5. If Project is the restore source, select the correct backup to restore. Click Next.

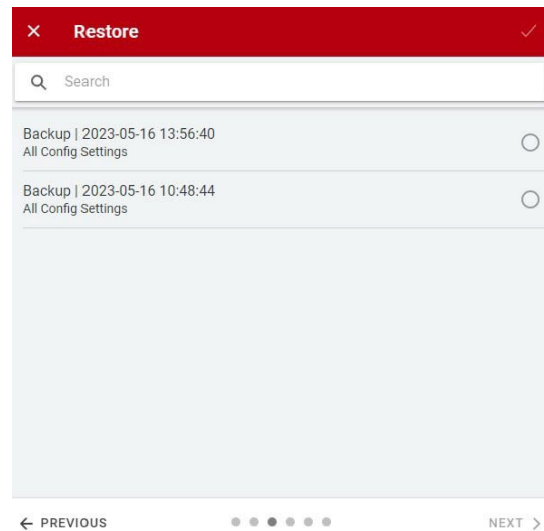

Figure 38: Backup file selection.

6. Select the files for restoring data into the drive, as shown in the figure below, and click Next.

NOTICE

It is possible to exclude Ethernet port settings when restoring data.

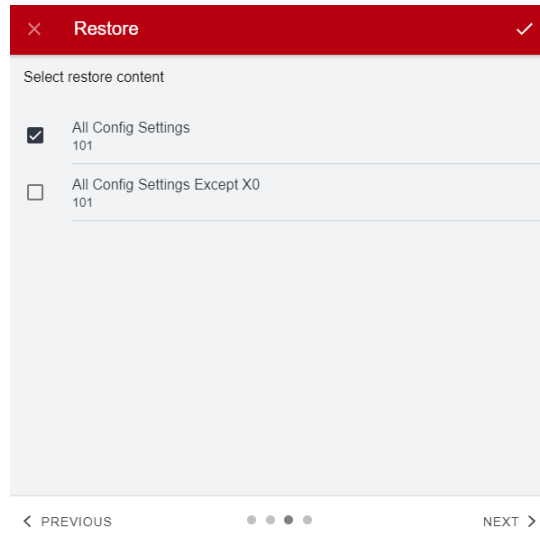

Figure 39: Restore content selection.

7. The system asks for confirmation for the restore action. Click Restore.

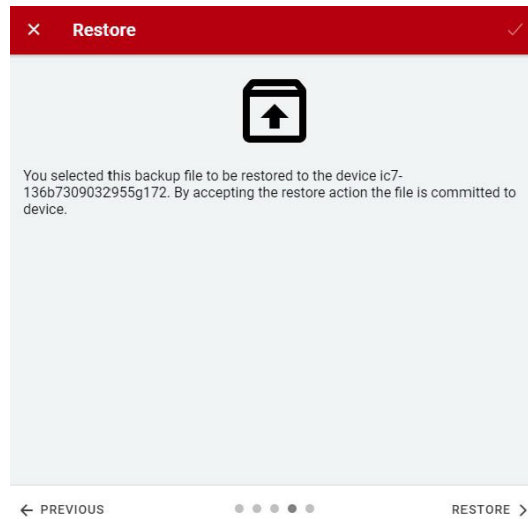

Figure 40: Restore confirmation.

On successful restore of data, a message is showed.

4 Application Software Structure and Overview

4.1 Parameter Groups, Related Content, and Settings

The detailed structure and hierarchy within the parameter groups can vary, depending on the purpose of the parameter group and the total number of parameters. However, the design principle of the structure is to keep the overall sequence while commissioning or setting up the drive, within a logical structure.

- All readouts for monitoring the drive and the application behavior are in group 1 Monitoring.
- Most of the drive configuration, application-specific parameters, and the configuration of external control signals are accessed via parameter group 2 Parameters.
- Features and functions such as Maintenance & Service, Functional Safety, and Device Settings are in parameter groups 3, 4, and 5.
- The hardware setup for I/O interface, Options, and communication interfaces is done in parameter groups 9 and 10.
- The visibility of some parameters and parameter groups depends on the drive hardware in use.
- The following table provides information about the parameter groups.

Index	Parameter group name	Description
1	Monitoring	Contains readout values for monitoring drive and application functions.
2	Parameters	Contains parameters for configuring most of the drive's functions.
3	Maintenance & Service	Contains parameters exclusively related to software information, events, counters, backup & restore, and expert tools.
4	Functional Safety	Contains parameters for configuring Safe Torque Off, as well as other safety features. <i>This menu appears only if applicable to the system.</i>
5	Device Settings	Contains parameters to customize and adapt the behavior of the drive and user interface design.
9	Option Board Settings	Contains hardware-related parameters to configure option board related settings.
10	Connectivity	Parameters to configure the inbuilt and optional communication of the drive system.

Application Guide

Parameter Group 1 st level	Parameter Group 2 nd level	Parameter Group 1 st level	Parameter Group 2 nd level	Parameter Group 1 st level	Parameter Group 2 nd level
1. Monitoring	1.1 Basic Monitoring	2. Parameters	2.1 Basic Parameters	3. Maintenance & Service	3.1 Software Information
	1.2 Control Mode and Reference Monitoring		2.2 Control Mode and References		3.2 Events
	1.3 Limit Monitoring		2.3 Limits		3.3. Operation Counters
	1.4 Control Place Monitoring		2.4 Ramps		3.4. I/O Testing
	1.5 Speed Control Monitoring		2.5 Digital and Analog Inputs		3.5 Backup and Restore
	1.6 Torque Control Monitoring		2.6 Digital and Analog Outputs		3.6 Expert Tools
	1.7 Power Control Monitoring		2.7 Start and Stop Settings	4 Functional Safety	4.1 Basic Settings
	1.8 Motor Control Monitoring		2.8 Control Places		4.2 STO
	1.9 Drive Control Monitoring		2.9 Motor Control		4.3 SS1
	1.10 Protection Monitoring		2.10 Speed Control	5 Device Settings	5.1 Time & Units
	1.11 Mechanical Brake Monitoring		2.11 Drive Control		5.2 Control Panel
	1.12 Custom Status Word Monitoring		2.12 Protections and Responses		5.3 Custom Status Word
	1.13 Power Unit Monitoring		2.13 Mechanical Brake Control	9. Option Board Settings	*System Specific Menu Content
	1.14 Rectifier Monitoring		2.14 Motor Breaker Control	10. Connectivity	Integrated Communication
	1.15 Advanced Harmonic Filter Monitoring		2.15 Output Filter		
	1.16 Fieldbus Process Data Monitoring		2.16 Inching		
	1.17 Functional Safety Monitoring		2.17 Advanced Harmonic Filter		
	1.18 Date & Time Monitoring				
	* System specific option board monitoring				

5 Configuration Examples

5.1 Introduction and Prerequisites

This section covers the basic configuration steps of a Propulsion and Machinery drive. The specific application may require more steps such as protection settings. Use the following topics as reference during the drive configuration/commissioning process:

- For control panel related configurations, see 3.2.3 Control Panel Basic Configurations.
- For information on using MyDrive® Insight, see 3.3.1 Getting Started with MyDrive® Insight.
- For detailed information about the parameters, see 6 Parameter Lists and 7 Parameter Descriptions.

Prerequisite:

NOTICE
Ensure that the drive is mounted safely as described in the relevant Operating Guide.

NOTICE
Selection lists with inputs and/or outputs consist of the name of the hardware option and the numbers of the terminals. For example, terminal number 13 of the Basic I/O is named Basic I/O T13 in the selection list.

5.2 Basic Setup of the Drive

The basic setup of the drive consists of the following configuration steps.

1. Configuring the power unit settings.
2. Setting the control mode.
3. Configuring the control place and its command inputs.
4. Configuring readouts in the control panel.

The steps described in detail are as follows.

1. Configure the power unit settings using the following parameters.

Parameter Index	Parameter Name	Example Setting	Parameter Number
2.1.10	Unit Voltage Class	High Voltage Range	2832
2.1.11	Overload Mode	Automatic	2833

Note: The recommended voltage values for the selections depend on the drive type, size, and other such considerations. For example, for T7 units (525–690 V AC):

- Low Voltage Range: 525–550 V
- Medium Voltage Range: 550–600 V
- High Voltage Range: 600–690 V
- Wide Voltage Range: 525–690 V

2. Configure the control mode using the following parameters.

Parameter Index	Parameter Name	Example Setting	Parameter Number
2.2.1.1.3	I/O Ctrl Mode	Speed Control Mode	3463
2.10.1.1.5	Speed Control Loop Type	Same as Flux Control Feedback	4038
2.9.5.10	Flux Control Feedback	Open loop	2502

- Configure the control place settings using the following parameters.

Parameter Index	Parameter Name	Example Setting	Parameter Number
2.8.1.1	Control Place Selection	I/O Control	114
2.8.3.1	I/O Start Forward Input	I/O and Relay T13 Digital Input	200
2.8.3.4	I/O Coast Inverse Input	I/O and Relay T16 Digital Input	201
2.2.2.1.1	I/O Speed Reference	[Analog Input Reference 1, None]	1913

- Configure the readouts in the control panel. See 3.2.3.3 Changing the Content of the Readout Screens.

5.3 Configuring Motor and Motor Control

The required configuration steps depend on the motor type selected in parameter **Motor Type (No. 407)**.

NOTICE

The parameters specified in the motor configuration cannot be adjusted when the motor is running.

Following are the steps.

- Configure basic motor data.
- Perform Advanced Motor Adaptation (AMA).
- Configure the advanced motor data if AMA is not performed.
- Configure motor control.

Following are the steps in detail.

- Configure basic motor data.

Parameter Index	Parameter Name	Example Setting	Parameter Number
2.1.1	Motor Type	Async. Induction Motor or Permanent Magnet Motor	407
2.1.2	Motor Nominal Power	As on the motor product label.	405
2.1.3	Motor Nominal Current	As on the motor product label.	400
2.1.4	Motor Nominal Speed	As on the motor product label.	402
2.1.5	Motor Nominal Frequency	As on the motor product label.	403
2.1.6	Motor Nominal Voltage	As on the motor product label.	401
2.9.3.1	Back EMF	Only for Permanent Magnet Motors. As on motor data sheet, as specified at 1000 RPM.	415

NOTICE

Changing the product label data causes a reset of the advanced motor data to defaults and a loss of AMA results.

2. Perform AMA. To perform the data measurement (in standstill), use the following parameter.

The advanced motor data which are needed for optimal motor control performance, and which are described in step 3 can be entered manually or measured and calculated based on AMA.

Parameter Index	Parameter Name	Example Setting	Parameter Number
2.1.8	AMA Mode	Motor Data	420

NOTICE

AMA requires an active start signal for execution. After AMA is performed, the setting of AMA Mode automatically switches to Off, and a notification must be confirmed. A new start signal is required for starting the motor. This is to avoid an unintended start caused by the active start signal.

WARNING

UNINTENDED START

When the drive is connected to AC mains, DC supply, or load sharing, the motor can start at any time, causing risk of death, serious injury, and equipment or property damage. The motor can start by activation of an external switch, a fieldbus command, an input from the Control Panel, via remote operation using MyDrive® Insight software, or after a cleared fault condition.

- Make sure the drive is not running before programming parameters.
- Disconnect the drive from the mains whenever personal safety considerations make it necessary to avoid an unintended motor start.
- Check that the drive, motor, and any driven equipment are in operational readiness.

3. Configure the advanced motor data if AMA is not performed. Setting these parameters is recommended for optimal motor control performance.

Induction motors:

Parameter Index	Parameter Name	Example Setting	Parameter Number
2.9.2.1	Stator Resistance Rs	Result of AMA or as on motor data sheet.	408
2.9.2.2	Rotor Resistance Rr	Result of AMA or as on motor data sheet.	409
2.9.2.3	Iron Loss Resistance Rfe	Result of AMA or as on motor data sheet.	413
2.9.2.4	Stator Leakage Reactance Xls	Result of AMA or as on motor data sheet.	440
2.9.2.5	Rotor Leakage Resistance Xlr	Result of AMA or as on motor data sheet.	441
2.9.2.6	Magnetizing Reactance Xm	Result of AMA or as on motor data sheet.	442

Permanent magnet motors:

Parameter Index	Parameter Name	Example Setting	Parameter Number
2.9.3.2	Stator Resistance Rs	Result of AMA or as on motor product label.	408
2.9.3.3	d-axis Inductance Ld	Result of AMA or as on motor product label.	417
2.9.3.4	d-axis Inductance LdSat	Result of AMA or as on motor product label.	418
2.9.3.5	Ld Current Point	Result of AMA or as on motor product label.	426
2.9.3.6	q-axis Inductance Lq	Result of AMA or as on motor product label.	427
2.9.3.7	q-axis Inductance LqSat	Result of AMA or as on motor product label.	422
2.9.3.8	Lq Current Point	Result of AMA or as on motor product label.	424

4. Configure Motor Control

Parameter Index	Parameter Name	Example Setting	Parameter Number
2.1.11	Motor Control Principle	FVC+ Control	2503
<p>Note: For the motor control principles VVC+ and U/f, the following applies:</p> <ul style="list-style-type: none"> • Configure compensations for slip and different application conditions in parameter group 2.9.6 • Enable and configure Automatic Energy Optimization (AEO) in parameter group 2.9.7.2 Torque & AEO. <p>For U/f, define the voltage and frequency points in parameter group 2.9.4 U/f Settings as required for the application.</p>			

5.4 Configuring Speed Control

This section describes the basic configuration for speed control in open loop. For advanced features such as enabling load drooping, see further details from related feature description chapters in 6 Parameter Lists and 7 Parameter Descriptions.

The following procedure describes the additional steps to control the speed according to the following wiring diagram.

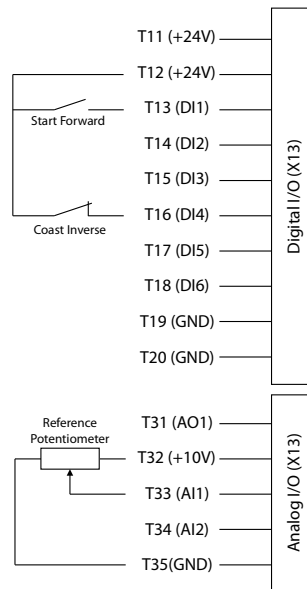

Figure 41: Wiring Diagram Example - Speed Control with I/O and Relay.

To configure speed control, perform the following:

1. Perform the steps in 5.2 Basic Setup of the Drive.
2. Perform the steps in 5.3 Configuring Motor and Motor Control.
3. Configure speed limit settings using the following parameters.

Parameter Index	Parameter Name	Example Setting	Parameter Number
2.3.1.1	Positive Speed Limit	50 Hz	1729
2.3.1.2	Negative Speed Limit	-50 Hz	1728
2.3.1.3	Minimum Speed	0 Hz	1722

4. Configure the ramp using the following parameters.

Parameter Index	Parameter Name	Example Setting	Parameter Number
2.4.1.1.1	Ramp Selection Input	None (Ramp 1)	1130
2.4.1.2.1	Ramp 1 Accel. Time	5 s	1101
2.3.1.2.2	Ramp 1 Decel. Time	5 s	1105

5. Configure the reference and input settings according to the selected reference type, using the following parameters.

Reference Settings:

Parameter Index	Parameter Name	Example Setting	Parameter Number
2.2.2.1.12	Speed Reference 1 Input	I/O and Relay T33 Analog Input	501
2.2.2.1.13	Speed Reference 1 Maximum	50 Hz	1724
2.2.2.1.14	Speed Reference 1 Minimum	0 Hz	1725

I/O And Relay Settings

Parameter Index	Parameter Name	Example Setting	Parameter Number
9.5.2.1	T33 Terminal Mode	Analog Input	2020
9.5.2.2	T33 Terminal Type	Voltage	2273
9.5.2.3	T33 Minimum Value	0 V	2272
9.5.2.4	T33 Maximum Value	10 V	2271

- Configure the settings for Inertia Estimation of the speed controller.

NOTICE

For achieving optimal motor control performance, perform an Inertia Estimation or, if the inertia is known, enter the inertia manually with parameter System Inertia (No. 667). Besides the settings already described earlier, adjust the following parameter.

Parameter Index	Parameter Name	Example Setting	Parameter Number
2.9.7.1.1	Inertia Estimation Mode	Without Load Profile	668

NOTICE

The recommended setting for parameter *Inertia Estimation Mode* (No. 668) depends on the torque characteristic configured in parameter *Torque Characteristic* (No. 2809). Select Without Load Profile for a constant torque load and With Profile for a variable torque load.

- To start the tuning process, apply a start signal to terminal 13 of I/O and Relay

5.5 Configuring Torque Control

While the drive is in torque control, the motor speed is not controlled. Therefore, motor speed can reach speed limits when the load application or upper system are not within the speed limits. For this reason, it is important to set the speed limits as described in 5.4 Configuring Speed Control. Since speed ramps can also be used as a limiting factor, check the ramp settings in step 6 of 5.4 Configuring Speed Control. Torque control is only available with the motor control principle FVC+.

The procedure is described in this chapter according to the following wiring diagram. The same wiring diagram is used in 5.4 Configuring Speed Control.

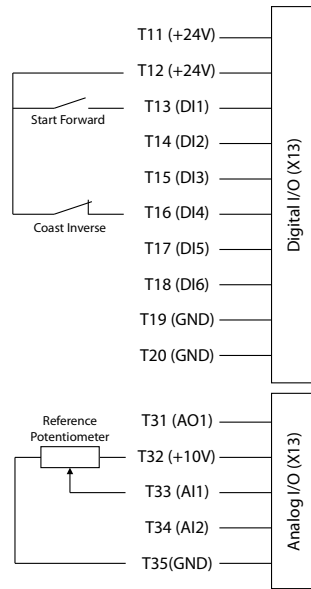

Figure 42: Wiring Diagram Example - Torque Control with I/O and Relay

To configure torque control, perform the following:

1. Perform the steps in 5.2 Basic Setup of the Drive.
2. Perform the steps in 5.3 Configuring Motor and Motor Control.
3. Configure the control mode for torque control using the following parameter.

Parameter index	Parameter name	Example setting	Parameter number
2.2.1.1.3	I/O Ctrl Mode	Torque Control Mode	3463

4. Configure the torque limit settings using the following parameters.

Parameter Index	Parameter Name	Example setting	Parameter Number
2.3.3.1	Positive Torque Limit	150%	1810
2.3.3.2	Negative Torque Limit	-150%	1811
2.3.3.3	Motor Torque Limit	100%	3156
2.3.3.9	Regenerative Torque Limit	100%	3160
2.3.1.10	Speed Limit Mode Torque Ctrl.	Pos./Neg. Frequency Limit	2332

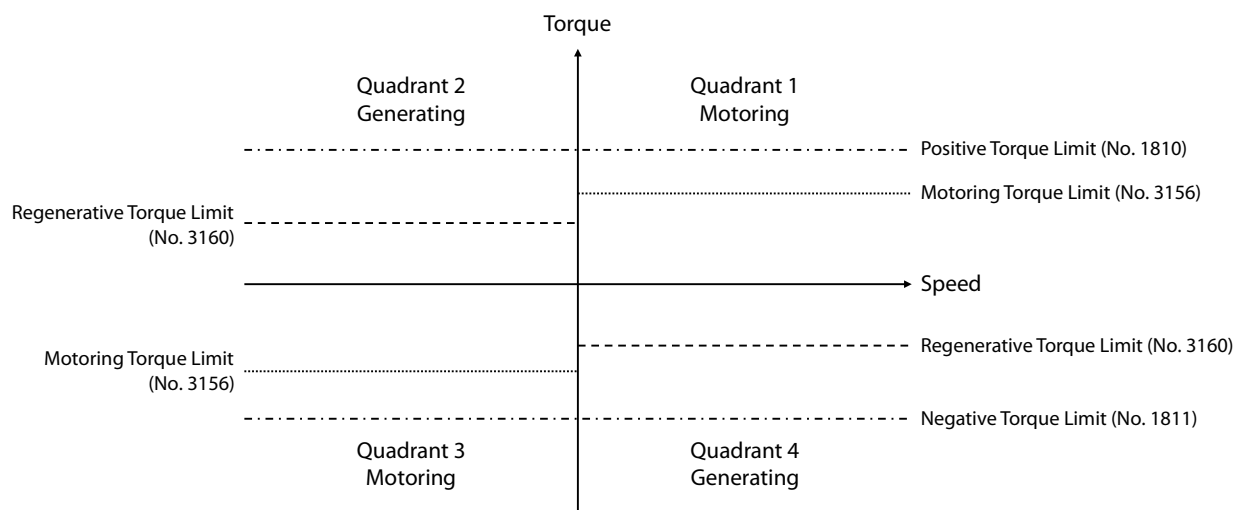

Figure 43: Torque limits in the Speed-Torque domain.

5. Configure reference settings and terminals used for the reference signal.

Reference Settings

Index	Parameter Name	Example setting	Parameter Number
2.2.3.1	I/O Torque Reference Source	Reference 1 Input	1927
2.2.3.9	Torque Reference 1 Input	I/O and Relay T33 Analog Input	4534
2.2.3.10	Torque Reference 1 Maximum	100%	4530
2.2.3.11	Torque Reference 1 Minimum	0%	4531
2.4.2.1	Torque Reference Increase Rate	5 %/s	2350
2.4.2.2	Torque Reference Decrease Rate	5 %/s	2351
2.4.2.3	Torque Reference Ramp Rate Source	Parameter	2352

I/O And Relay Settings

Parameter Index	Parameter Name	Example Setting	Parameter number
9.5.2.1	T33 Terminal Mode	Analog Input	2020
9.5.2.2	T33 Terminal Type	Voltage	2273
9.5.2.3	T33 Minimum Value	0V	2272
9.5.2.4	T33 Maximum Value	10 V	2271

5.6 Configuring Power Control

Similarly, to torque control, while the drive is in power control, the motor speed is not directly controlled. Take the same precautions as mentioned in 5.5 Configuring Torque Control. Power control is also available only with the FVC+ motor control principle.

The following procedure describes the additional steps to control the power according to the following wiring diagram.

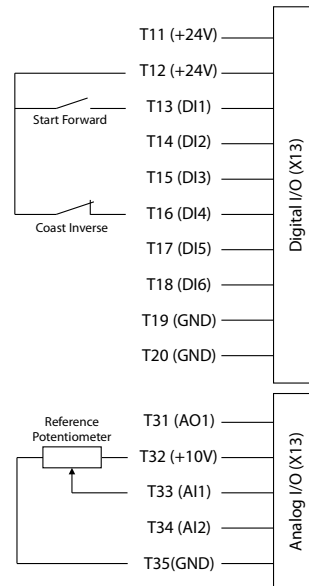

Figure 44: Wiring Diagram Example - Power Control with I/O and Relay

To configure power control, perform the following:

1. Configure the power limit settings using the following parameters.

Parameter Index	Parameter Name	Example Setting	Parameter Number
2.3.4.2	Motor Power Limit	100%	3167
2.3.4.9	Regenerative Power Limit	100%	3166

2. Configure reference settings and terminals used for the reference signal.

Reference Settings:

Parameter Index	Parameter Name	Example Setting	Parameter Number
2.2.4.1	I/O Power Reference	Reference 1 Input	1930
2.2.4.8	Power Reference 1 Input	I/O and Relay T33 Analog Input	4573
2.2.4.9	Power Reference Min.	0%	8027
2.2.4.10	Power Reference Max.	100%	4571

I/O And Relay Settings:

Parameter Index	Parameter Name	Example Setting	Parameter Number
9.5.2.1	T33 Terminal Mode	Analog Input	2020
9.5.2.2	T33 Terminal Type	Voltage	2273
9.5.2.3	T33 Minimum Value	0 V	2272
9.5.2.4	T33 Maximum Value	10 V	2271

3. Configure control mode to power control using the following parameter.

Parameter Index	Parameter Name	Example Setting	Parameter Number
2.2.1.1.3	I/O Ctrl Mode	Power Control Mode	3463

6 Parameter Lists

6.1 How to read parameter lists

The following chapters contain tables presenting the basic attributes of each parameter available in the application software. Each chapter represents a single subgroup within the menu structure.

The tables have the following format:

Index	Name	Num	Min	Max	Default	Unit	Reso	Handling Type	Data Type
1.2.3.4.5	Parameter Name	1234	-10.0 ^[1]	10.0 ^[1]	0.0	Hz	0.01	Config	REAL
6.7.8	Array Parameter Name	5678	0	5	[1,2]		1	Config	UINT

[1]: Value depends on the power unit specification.

- Index: shows the location of the parameter within the menu structure.
- Name: shows the parameter name.
- Num: shows the parameter number.
- Min: shows the minimum value that the parameter can have. For arrays, the single given value applies to all array elements.
- Max: shows the maximum value that the parameter can have. For arrays, the single given value applies to all array elements.
- Default: shows the value that the parameter has with factory default settings. For arrays, each element value is shown comma-separated within square brackets.
- Unit: shows the unit symbol of the parameter. Nothing is shown if the parameter is unitless.
- Reso: shows the resolution or display/edit precision of the parameter.
- Handling Type: shows whether the drive handles the parameter as a constantly changing *process* value or an infrequently changed *config(uration)* value. Use this field as a guide for evaluating how often to write to parameters when creating custom fieldbus configurations.
- Data type: shows the IEC 61131 elementary data type of the parameter.
- Possible references within any field will note of special conditions that are explained after the table.

6.1.1 Understanding Data Types

The following is an overview of the data types used in the iC7 application software. They are IEC 61131 elementary data types.

Data type	Description	Size (Bits)	Range
BOOL	Boolean	1	0...1
INT	Integer	16	-32,768...32,767
DINT	Double Integer	32	-2,147,483,648 up to 2,147,483,647
USINT	Unsigned short integer	8	0 up to 255
UINT	Unsigned integer	16	0 up to 65,535
UDINT	Unsigned double integer	32	0 up to 4,294,967,295
REAL	Real numbers	32	-3.402823466 E+38 (approximately 7 digits) up to -1.175494351E-38 (approximately 7 digits) and

Data type	Description	Size (Bits)	Range
			+1.175494351 E-38 (approximately 7 digits) up to +3.402823466 E+38 (approximately 7 digits)
WORD	Bit string of length 16	16	0...65,535 (16#00...16#FFFF)
STRING	Sequence of characters	N/A	1 Byte per character
ULINT	Unsigned long integer	64	0–18446744073709551615
DATE_AND_TIME	Date and time information	64	N/A

6.2 Monitoring

6.2.1 Basic Monitoring

Index	Name	Num	Min	Max	Default	Unit	Reso	Handling Type	Data Type
1.1.1	Motor Current	9000	0.0	3.4e+38	0.0	A	0.01	Process	REAL
1.1.2	Motor Voltage	9005	0.0	3.4e+38	0.0	V	0.01	Process	REAL
1.1.3	Motor Torque	9009	-1e+07	1e+07	0.0	Nm	0.01	Process	REAL
1.1.4	Motor Shaft Power	9008	-3.4e+38	3.4e+38	0.0	kW	0.01	Process	REAL
1.1.5	Motor Shaft Speed	9010	-1e+05	1e+05	0.0	RPM	0.01	Process	REAL
1.1.6	Motor Power Factor	4618	-1.0	1.0	0.0		0.01	Process	REAL
1.1.7	Output Frequency	9015	-3.4e+38	3.4e+38	0.0	Hz	1	Process	REAL
1.1.8	DC-link Voltage	9044	0.0	3.4e+38	0.0	V	0.01	Process	REAL
1.1.9	DC-link Power	5117	-3.4e+38	3.4e+38	0.0	kW	0.01	Process	REAL
1.1.10	Application Status Word 1	6201	0x0	0xffff	0x0		1	Process	WORD
1.1.11	Application Status Word 2	6202	0x0	0xffff	0x0		1	Process	WORD
1.1.12	Fault Status Word 1	6203	0x0	0xffffffff	0x0		1	Process	DWORD
1.1.13	Fault Status Word 2	6204	0x0	0xffffffff	0x0		1	Process	DWORD
1.1.14	Warning Status Word 1	6205	0x0	0xffffffff	0x0		1	Process	DWORD
1.1.15	Warning Status Word 2	6206	0x0	0xffffffff	0x0		1	Process	DWORD
1.1.16	Start Ready Status Word	6207	0x0	0xffff	0x0		1	Process	WORD
1.1.17	Last Fault Number	1610	0	65535	0		1	Process	UINT
1.1.18	Last Warning Number	1609	0	65535	0		1	Process	UINT

6.2.2 Control Mode and Reference Monitoring

Index	Name	Num	Min	Max	Default	Unit	Reso	Handling Type	Data Type
1.2.1	Active Control Mode	3460	0	2	0		1	Process	UINT
1.2.2	Speed Reference	1718	-2000.0	2000.0	0.0	Hz	0.01	Process	REAL
1.2.3	Torque Reference	1821	-300.0	300.0	0.0	%	0.01	Process	REAL
1.2.4	Power Reference	1820	-300.0	300.0	0.0	%	0.01	Process	REAL

6.2.3 Limit Monitoring

Index	Name	Num	Min	Max	Default	Unit	Reso	Handling Type	Data Type
1.3.1	Relative Output Current Limit	2700	0.0	300.0	0.0	%	0.01	Process	REAL
1.3.2	Torque Limit Motoring	1812	0.0	500.0	300.0	%	0.01	Process	REAL
1.3.3	Torque Limit Regenerative	1813	0.0	500.0	300.0	%	0.01	Process	REAL
1.3.4	Power Limit Motor	1814	0.0	1000.0	300.0	%	0.01	Process	REAL
1.3.5	Power Limit Regenerative	1815	0.0	1000.0	300.0	%	0.01	Process	REAL
1.3.6	Overvoltage Control Limit	6544	-16.8e+6 ^[1]	16.8e+6 ^[1]	796.5 ^[1]	V	0.01	Process	REAL
1.3.7	Undervoltage Control Limit	6546	100.0 ^[1]	1300.0 ^[1]	100.0 ^[1]	V	0.01	Process	REAL
1.3.8	Brake Power	2933	0.0	3.4e+38	0.0	kW	1	Process	REAL
1.3.9	Average Brake Power	2934	0.0	3.4e+38	0.0	kW	1	Process	REAL

[1]: Value depends on the power unit specification.

6.2.4 Control Place Monitoring

Index	Name	Num	Min	Max	Default	Unit	Reso	Handling Type	Data Type
1.4.1	Active Control Place	113	0	4	0		1	Process	UINT
1.4.2	FB Forcing Requested	116	0	1	0		1	Process	BOOL
1.4.3	I/O Forcing Requested	117	0	1	0		1	Process	BOOL
1.4.4	Advanced Forcing Requested	118	0	1	0		1	Process	BOOL
1.4.5	Local Control Forcing Requested	124	0	1	0		1	Process	BOOL

6.2.5 Speed Control Monitoring

Index	Name	Num	Min	Max	Default	Unit	Reso	Handling Type	Data Type
1.5.1	Motor Shaft Speed	9010	-1e+05	1e+05	0.0	RPM	0.01	Process	REAL
1.5.2	Motor Electrical Speed	9011	-10000.0	10000.0	0.0	Hz	0.01	Process	REAL
1.5.3	Output Frequency	9015	-3.4e+38	3.4e+38	0.0	Hz	1	Process	REAL
1.5.4	Feedback Speed	9007	-10000.0	10000.0	0.0	RPM	0.01	Process	REAL
1.5.5	Feedback Electrical Angle	9016	0.0	360.0	0.0	°	0.1	Process	REAL
1.5.6	Speed Error	4023	-3.4e+38	3.4e+38	0.0	Hz	0.01	Process	REAL
1.5.7	Speed Reference	1718	-2000.0	2000.0	0.0	Hz	0.01	Process	REAL
1.5.8	Speed Reference Before Ramp	6049	-2000.0	2000.0	0.0	Hz	0.01	Process	REAL
1.5.9	Speed Reference After Ramp	6150	-3.4e+38	3.4e+38	0.0	Hz	0.01	Process	REAL
1.5.10	Final Speed Reference	6151	-3.4e+38	3.4e+38	0.0	Hz	0.01	Process	REAL
1.5.11	Feedback Electrical Speed	9012	-16.8e+6	16.8e+6	0.0	Hz	0.01	Process	REAL
1.5.12	Load Drooping Speed	674	0.0	2000.0	0.0	Hz	0.01	Process	REAL

6.2.6 Torque Control Monitoring

Index	Name	Num	Min	Max	Default	Unit	Reso	Handling Type	Data Type
1.6.1	Motor Torque	9009	-1e+07	1e+07	0.0	Nm	0.01	Process	REAL
1.6.2	Relative Motor Torque	1708	-300.0	300.0	0.0	%	0.01	Process	REAL
1.6.3	Torque Limit Motoring	1812	0.0	500.0	300.0	%	0.01	Process	REAL
1.6.4	Torque Limit Regenerative	1813	0.0	500.0	300.0	%	0.01	Process	REAL
1.6.5	Torque Reference	1821	-300.0	300.0	0.0	%	0.01	Process	REAL
1.6.6	Torque Ref. Ramp Out	6152	-300.0	300.0	0.0	%	0.01	Process	REAL
1.6.7	Torque Reference Final	6154	-300.0	300.0	0.0	%	0.01	Process	REAL

6.2.7 Power Control Monitoring

Index	Name	Num	Min	Max	Default	Unit	Reso	Handling Type	Data Type
1.7.1	Relative Motor Shaft Power	1707	-300.0	300.0	0.0	%	0.01	Process	REAL
1.7.2	Power Reference	1820	-300.0	300.0	0.0	%	0.01	Process	REAL
1.7.3	Power Ref. Ramp Out	4076	-300.0	300.0	0.0	%	0.01	Process	REAL
1.7.4	Power Limit Motor	1814	0.0	1000.0	300.0	%	0.01	Process	REAL
1.7.5	Power Limit Regenerative	1815	0.0	1000.0	300.0	%	0.01	Process	REAL

6.2.8 Motor Control Monitoring

6.2.8.1 Motor Status

Index	Name	Num	Min	Max	Default	Unit	Reso	Handling Type	Data Type
1.8.1.1	Motor Current	9000	0.0	3.4e+38	0.0	A	0.01	Process	REAL
1.8.1.2	Relative Motor Current	9001	0.0	200.0	0.0	%	0.01	Process	REAL
1.8.1.3	U-phase RMS Current	9020	0.0	3.4e+38	0.0	A	0.01	Process	REAL
1.8.1.4	V-phase RMS Current	9021	0.0	3.4e+38	0.0	A	0.01	Process	REAL
1.8.1.5	W-phase RMS Current	9022	0.0	3.4e+38	0.0	A	0.01	Process	REAL
1.8.1.6	Motor Voltage	9005	0.0	3.4e+38	0.0	V	0.01	Process	REAL
1.8.1.7	U-V RMS voltage	9023	0.0	3.4e+38	0.0	V	0.01	Process	REAL
1.8.1.8	V-W RMS voltage	9024	0.0	3.4e+38	0.0	V	0.01	Process	REAL
1.8.1.9	W-U RMS voltage	9025	0.0	3.4e+38	0.0	V	0.01	Process	REAL
1.8.1.10	Motor Torque	9009	-1e+07	1e+07	0.0	Nm	0.01	Process	REAL
1.8.1.11	Relative Motor Torque	1708	-300.0	300.0	0.0	%	0.01	Process	REAL
1.8.1.12	Motor Shaft Power	9008	-3.4e+38	3.4e+38	0.0	kW	0.01	Process	REAL
1.8.1.13	Relative Motor Shaft Power	1707	-300.0	300.0	0.0	%	0.01	Process	REAL
1.8.1.14	Motor Electrical Power	9043	-3.4e+38	3.4e+38	0.0	kW	0.01	Process	REAL
1.8.1.15	Motor Thermal Load (ETR)	2951	0.0	100.0	0.0	%	0.01	Process	REAL
1.8.1.16	AMA Progress	429	0.0	100.0	0.0	%	1	Process	REAL

6.2.8.2 Motor Control Status

Index	Name	Num	Min	Max	Default	Unit	Reso	Handling Type	Data Type
1.8.2.1	Motor Control Status Word	1714	0x0	0xffff	0x0		1	Process	WORD
1.8.2.2	Motor Control Ready Status Word	1716	0x0	0xffff	0x0		1	Process	WORD
1.8.2.3	Motor Regulator Status Word	1715	0x0	0xffff	0x0		1	Process	WORD

6.2.8.3 Load Status

Index	Name	Num	Min	Max	Default	Unit	Reso	Handling Type	Data Type
1.8.3.1	Inertia Estimation Status	666	0	3	0		1	Process	UINT

6.2.9 Drive Control Monitoring

Index	Name	Num	Min	Max	Default	Unit	Reso	Handling Type	Data Type
1.9.1	Actual Switching Frequency	2923	0.0	16000.0	0.0	Hz	0.01	Process	REAL
1.9.2	Modulation Index	5101	0.0	2.0	0.0		0.01	Process	REAL
1.9.3	Control Unit Temperature	2952	-50.0	200.0	0.0	°C	0.01	Process	REAL

6.2.10 Protection Monitoring

6.2.10.1 Measured Temp. Protection Status

Index	Name	Num	Min	Max	Default	Unit	Reso	Handling Type	Data Type
1.10.1.1	Protection 1 Temp.	5200	-300.0	300.0	0.0	°C	0.01	Process	REAL
1.10.1.2	Protection 2 Temp.	5201	-300.0	300.0	0.0	°C	0.01	Process	REAL
1.10.1.3	Protection 3 Temp.	5202	-300.0	300.0	0.0	°C	0.01	Process	REAL
1.10.1.4	Protection 4 Temp.	5203	-300.0	300.0	0.0	°C	0.01	Process	REAL
1.10.1.5	Protection 5 Temp.	5204	-300.0	300.0	0.0	°C	0.01	Process	REAL
1.10.1.6	Protection 6 Temp.	5205	-300.0	300.0	0.0	°C	0.01	Process	REAL
1.10.1.7	Protection 7 Temp.	5273	-300.0	300.0	0.0	°C	0.01	Process	REAL
1.10.1.8	Protection 8 Temp.	5274	-300.0	300.0	0.0	°C	0.01	Process	REAL
1.10.1.9	Protection 9 Temp.	5275	-300.0	300.0	0.0	°C	0.01	Process	REAL
1.10.1.10	Protection 10 Temp.	5276	-300.0	300.0	0.0	°C	0.01	Process	REAL

6.2.11 Mechanical Brake Control Monitoring

Index	Name	Num	Min	Max	Default	Unit	Reso	Handling Type	Data Type
1.11.1	Mechanical Brake Status Word	3016	0x0	0xffff	0x0		1	Process	WORD
1.11.2	Mechanical Brake State	3017	0	32767	0		1	Process	INT
1.11.3	Brake Release Time Detected	3041	0.0	10000.0	0.0	s	0.01	Process	REAL

6.2.12 Custom Status Word Monitoring

Index	Name	Num	Min	Max	Default	Unit	Reso	Handling Type	Data Type
1.12.1	Custom Status Word	2410	0x0	0xffff	0x0		1	Process	WORD

6.2.13 Power Unit Monitoring

Index	Name	Num	Min	Max	Default	Unit	Reso	Handling Type	Data Type
1.13.1	Power Capacity	2836	0.0	100.0	100.0	%	1	Process	REAL
1.13.2	Unit Nominal Voltage	2830	0.0	3.4e+38	400.0	V	0.01	Config	REAL
1.13.3	Unit Nominal Current	2831	0.0	3.4e+38	23.0	A	0.01	Config	REAL
1.13.4	Heat Sink Temperature	2950	-50.0	200.0	0.0	°C	0.01	Process	REAL
1.13.5	Active Power Unit Mask	249	0x0	0xffffffff	0x0		1	Process	DWORD

6.2.14 Rectifier Monitoring

Index	Name	Num	Min	Max	Default	Unit	Reso	Handling Type	Data Type
1.14.1	Grid Frequency	9041	-3.4e+38	3.4e+38	0.0	Hz	0.01	Process	REAL
1.14.2	Line-To-Line Voltage (RMS)	9040	0.0	3.4e+38	0.0	V	0.01	Process	REAL
1.14.3	L1-L2 Line Voltage (RMS)	9048	0.0	3.4e+38	0.0	V	0.01	Process	REAL
1.14.4	L2-L3 Line Voltage (RMS)	9049	0.0	3.4e+38	0.0	V	0.01	Process	REAL
1.14.5	L3-L1 Line Voltage (RMS)	9050	0.0	3.4e+38	0.0	V	0.01	Process	REAL
1.14.6	Grid Voltage Imbalance	9047	0.0	100.0	0.0	%	0.01	Process	REAL
1.14.7	Total Harmonic Distortion (THDv)	9046	0.0	100.0	0.0	%	0.01	Process	REAL
1.14.8	Grid Active Power	9064	-3.4e+38	3.4e+38	0.0	kW	0.01	Process	REAL

6.2.15 Advanced Harmonic Filter Monitoring

Index	Name	Num	Min	Max	Default	Unit	Reso	Handling Type	Data Type
1.15.1	AHF Capacitor Connected	5410	0	1	0		1	Process	BOOL

6.2.16 Fieldbus Process Data Monitoring

Index	Name	Num	Min	Max	Default	Unit	Reso	Handling Type	Data Type
1.16.1	FB PCD Control Word	1335	0x0	0xffff	0x0		1	Process	WORD
1.16.2	FB PCD Main Reference Value	1339	-3.4e+38	3.4e+38	0.0		0.01	Process	REAL
1.16.3	FB PCD Status Word	1307	0x0	0xffff	0x0		1	Process	WORD
1.16.4	FB PCD Main Actual Value	1308	-3.4e+38	3.4e+38	0.0		0.01	Process	REAL
1.15.5	FB PCD Speed Reference	1345	-1000.0	100.0	0.0	Hz	0.01	Process	REAL
1.16.6	FB PCD Torque Reference	4543	-300.0	300.0	0.0	%	0.01	Process	REAL
1.16.7	FB PCD Power Reference	4575	-300.0	300.0	0.0	%	0.01	Process	REAL
1.16.8	FB PCD Current Limit	3192	0.0	200.0	0.0	%	0.01	Process	REAL
1.16.9	FB PCD Motor Torque Limit	3157	0.0	300.0	0.0	%	0.01	Process	REAL
1.16.10	FB PCD Regenerating Torque Limit	3161	0.0	300.0	0.0	%	0.01	Process	REAL
1.16.11	FB PCD Motor Power Limit	3175	0.0	300.0	0.0	%	0.01	Process	REAL
1.16.12	FB PCD Regenerating Power Limit	3176	0.0	300.0	0.0	%	0.01	Process	REAL
1.16.13	FB PCD Speed Ref. Adjust	4516	0.0	100.0	0.0	%	0.01	Process	REAL
1.16.14	FB PCD Overvoltage Limit	4512	0.0	320.0	0.0	%	0.01	Process	REAL
1.16.15	FB PCD Undervoltage Limit	4510	0.0	320.0	0.0	%	0.01	Process	REAL
1.16.16	FB PCD Power Limit Increase Rate	4529	0.0	10000.0	0.0	%/s	0.01	Process	REAL
1.16.17	FB PCD Power Ref. Increase Rate	4538	0.0	10000.0	0.0	%/s	0.01	Process	REAL
1.16.18	FB PCD Power Ref. Decrease Rate	4539	0.0	10000.0	0.0	%/s	0.01	Process	REAL
1.16.19	FB PCD Operation Control Word	4564	0	65535	0		1	Process	UDINT
1.16.20	FB PCD Master Motor Torque	4506	-1000.0	1000.0	0.0	%	0.01	Process	REAL
1.16.21	FB PCD Control Word 2	1347	0x0	0xffff	0x0		1	Process	WORD
1.16.22	FB PCD Status Word 2	1344	0x0	0xffff	0x0		1	Process	WORD
1.16.23	FB PCD Torque Ref. Increase Rate	2353	0.0	1000.0	0.0	%/s	0.01	Process	REAL
1.16.24	FB PCD Torque Ref. Decrease Rate	2354	0.0	1000.0	0.0	%/s	0.01	Process	REAL

6.2.17 Functional Safety Monitoring

Index	Name	Num	Min	Max	Default	Unit	Reso	Handling Type	Data Type
1.17.1	Functional Safety Status Word	4024	0x0	0xffff	0x0		1	Process	WORD

6.2.18 Date & Time Monitoring

Index	Name	Num	Min	Max	Default	Unit	Reso	Handling Type	Data Type
1.18.1	Date & Time	2799	01 Jan 1984 0:00.00	06 Sep 2163 0:00.00	-		1 s	Process	DATE_ AND_ TIME
1.18.2	Active NTP Server	6230	0.0.0.0	255.255.255.255	-		1	Process	STRING
1.18.3	Last Time Received (NTP)	6235	01 Jan 1984 0:00.00	06 Sep 2163 0:00.00	-		1	Process	DATE_ AND_ TIME

6.2.19 Logic Monitoring

Index	Name	Num	Min	Max	Default	Unit	Reso	Handling Type	Data Type
1.19.1	Logic Speed Reference	21110	-1000	1000	0	Hz	0.01	Process	REAL
1.19.2	Logic Torque Reference	21111	-300	300	0	%	0.01	Process	REAL
1.19.3	Logic Power Reference	21114	-300	300	0	%	0.01	Process	REAL
1.19.4	Logic State	21094	-	-	0		1	Process	UINT
1.19.5	Logic Time in Current State	21095	0	360000 00	0	s	1 s	Process	UINT
1.19.6	Logic Running Mode	21091	0	2	0	-	1	Config	UINT

6.2.20 Master Follower Monitoring

Index	Name	Num	Min	Max	Default	Unit	Reso	Handling Type	Data Type
1.20.1	Active Master Follower Mode	5606	0	3	0		1	Process	UINT

6.2.21 I/O And Relay Status

This group appears only if an I/O And Relay OC7C1 option is included in the drive. This menu appears as many times as there are these options in the system. Each menu and its parameters have the suffix of their option slot.

Refer to 6.7.1.1 I/O And Relay Status for the content of this menu.

6.2.22 Encoder/Resolver Status

This group appears only if an Encoder/Resolver OC7M0 option is included in the drive. This menu appears as many times as there are these options in the system. Each menu and its parameters have the suffix of their option slot.

Refer to 6.7.2.1 Encoder/Resolver Status for the content of this menu.

6.2.23 Temperature Measurement Status

This group appears only if a Temperature Measurement OC7T0 option is included in the drive. This menu appears as many times as there are these options in the system. Each menu and its parameters have the suffix of their option slot.

Refer to 6.7.3.1 Temperature Measurement Status for the content of this menu.

6.3 Parameters

6.3.1 Basic Parameters

Index	Name	Num	Min	Max	Default	Unit	Reso	Handling Type	Data Type
2.1.1	Motor Type	407	0	65535	0		1	Config	UINT
2.1.2	Motor Nominal Power	405	-3.4e+38	3.4e+38	5500.0 ^[1]	kW	0.01	Config	REAL
2.1.3	Motor Nominal Current	400	-3.4e+38	3.4e+38	11.5 ^[1]	A	0.01	Config	REAL
2.1.4	Motor Nominal Speed	402	0.0	1e+05	1450.0 ^[1]	RPM	0.01	Config	REAL
2.1.5	Motor Nominal Frequency	403	0.0	2000.0	50.0 ^[1]	Hz	0.01	Config	REAL
2.1.6	Motor Nominal Voltage	401	-3.4e+38	3.4e+38	400.0 ^[1]	V	0.01	Config	REAL
2.1.7	DC-link Nominal Voltage	2834	0.0	1500.0	0.0 ^[1]	V	0.01	Config	REAL
2.1.8	AMA Mode	420	0	4	0		1	Process	UINT
2.1.9	Motor Control Principle	2503	0	65535	0		1	Config	UINT
2.1.10	Unit Voltage Class	2832	1	4	1		1	Config	UINT
2.1.11	Overload Mode	2833	0	3	2		1	Config	UINT

[1] Value depends on the power unit specification.

6.3.2 Control Mode and References

6.3.2.1 Control Mode

6.3.2.1.1 Ctrl Mode Configuration

Index	Name	Num	Min	Max	Default	Unit	Reso	Handling Type	Data Type
2.2.1.1.1	HMI Control Mode	3461	0	3	0		1	Config	UINT
2.2.1.1.2	Fieldbus Control Mode	3462	0	3	0		1	Config	UINT
2.2.1.1.3	I/O Control Mode	3463	0	3	0		1	Config	UINT
2.2.1.1.4	Advanced Control Mode	3464	0	3	0		1	Config	UINT

6.3.2.1.2 Preset Ctrl Mode

Index	Name	Num	Min	Max	Default	Unit	Reso	Handling Type	Data Type
2.2.1.2.1	Control Mode Preset 1	3465	0	2	0		1	Config	UINT
2.2.1.2.2	Control Mode Preset 2	3466	0	2	0		1	Config	UINT
2.2.1.2.3	Control Mode Preset 3	3467	0	2	0		1	Config	UINT
2.2.1.2.4	Control Mode Preset 4	3468	0	2	0		1	Config	UINT
2.2.1.2.5	Control Mode Preset Input 1	3469	0	29999	0		1	Config	UINT
2.2.1.2.6	Control Mode Preset Input 2	3470	0	29999	0		1	Config	UINT

6.3.2.2 Speed Reference

6.3.2.2.1 Basic Settings

Index	Name	Num	Min	Max	Default	Unit	Reso	Handling Type	Data Type
2.2.2.1.1	I/O Speed Reference	1913	0	9	[3,0]		1	Config	UINT
2.2.2.1.2	I/O Speed Reference Logic	1910	0	8	0		1	Config	UINT
2.2.2.1.3	I/O Speed Reference Toggle Input	1940	0	29999	0		1	Config	UINT
2.2.2.1.4	Fieldbus Speed Reference	1914	0	9	[2,0]		1	Config	UINT
2.2.2.1.5	Fieldbus Speed Reference Logic	1911	0	8	0		1	Config	UINT
2.2.2.1.6	Fieldbus Speed Reference Toggle Input	1939	0	29999	0		1	Config	UINT
2.2.2.1.7	Adv. Speed Reference	1915	0	9	[0,0]		1	Config	UINT
2.2.2.1.8	Adv. Speed Reference Logic	1916	0	8	0		1	Config	UINT
2.2.2.1.9	Adv. Speed Reference Toggle Input	1941	0	29999	0		1	Config	UINT
2.2.2.1.10	Local Speed Ref. Source	1912	1	9	1		1	Config	UINT
2.2.2.1.11	Control Panel Speed Reference	6153	-1000.0	1000.0	0.0	Hz	0.01	Process	REAL
2.2.2.1.12	Speed Reference 1 Input	501	0	29999	10133		1	Config	UINT
2.2.2.1.13	Speed Reference 1 Max.	1724	-1000.0	1000.0	100.0	Hz	0.01	Config	REAL
2.2.2.1.14	Speed Reference 1 Min.	1725	-1000.0	1000.0	0.0	Hz	0.01	Config	REAL
2.2.2.1.15	Speed Ref. 1 Input Failure Response	4591	0	2	0		1	Config	UINT
2.2.2.1.16	Speed Reference 2 Input	502	0	29999	10134		1	Config	UINT
2.2.2.1.17	Speed Reference 2 Max.	1726	-1000.0	1000.0	100.0	Hz	0.01	Config	REAL
2.2.2.1.18	Speed Reference 2 Min.	1727	-1000.0	1000.0	0.0	Hz	0.01	Config	REAL
2.2.2.1.19	Speed Ref. 2 Input Failure Response	4592	0	2	0		1	Config	UINT
2.2.2.1.20	Fieldbus Speed Signal Max	6312	-32768	32767	10000		1	Config	INT
2.2.2.1.21	Fieldbus Speed Signal Min	6313	-32768	32767	-10000		1	Config	INT
2.2.2.1.22	Fieldbus Speed Scale Max	6310	-1000.0	1000.0	100.0	Hz	0.001	Config	REAL
2.2.2.1.23	Fieldbus Speed Scale Min	6311	-1000.0	1000.0	-100.0	Hz	0.001	Config	REAL
2.2.2.1.24	Speed Ref. Fieldbus Failure Response	4593	0	2	0		1	Config	UINT
2.2.2.1.25	Speed Ref. Failure Preset	4594	-320.0	320.0	0.0	Hz	0.01	Config	REAL
2.2.2.1.26	Speed Ref. Filter Tc	1719	0.0	1000.0	0.0	s	0.01	Config	REAL

6.3.2.2.2 Reference Freeze

Index	Name	Num	Min	Max	Default	Unit	Reso	Handling Type	Data Type
2.2.2.2.1	Freeze Input	1008	0	29999	0		1	Config	UINT
2.2.2.2.2	Freeze Up Input	1001	0	29999	0		1	Config	UINT

Index	Name	Num	Min	Max	Default	Unit	Reso	Handling Type	Data Type
2.2.2.2.3	Freeze Down Input	1002	0	29999	0		1	Config	UINT
2.2.2.2.4	Freeze Ramp Time	1003	0.0	1000.0	10.0	s	0.01	Config	REAL
2.2.2.2.5	Freeze Ramp Delay	1004	0	4.29e+9	4000	s	1	Config	UDINT
2.2.2.2.6	Freeze Step Delta	1005	0.0	10000.0	1.0	Hz	0.01	Config	REAL
2.2.2.2.7	Freeze Initialization	1006	0	1	0		1	Config	BOOL
2.2.2.2.8	Freeze Ramp/Step Mode	1007	0	2	0		1	Config	UINT

6.3.2.2.3 Speed Reference Presets

Index	Name	Num	Min	Max	Default	Unit	Reso	Handling Type	Data Type
2.2.2.3.1	Preset Speed Reference Selector	702	0	8	1		1	Config	UINT
2.2.2.3.2	Preset Speed 1	703	-1000.0	1000.0	97.0	Hz	0.01	Config	REAL
2.2.2.3.3	Preset Speed 2	704	-1000.0	1000.0	20.0	Hz	0.01	Config	REAL
2.2.2.3.4	Preset Speed 3	705	-1000.0	1000.0	30.0	Hz	0.01	Config	REAL
2.2.2.3.5	Preset Speed 4	706	-1000.0	1000.0	40.0	Hz	0.01	Config	REAL
2.2.2.3.6	Preset Speed 5	707	-1000.0	1000.0	50.0	Hz	0.01	Config	REAL
2.2.2.3.7	Preset Speed 6	708	-1000.0	1000.0	60.0	Hz	0.01	Config	REAL
2.2.2.3.8	Preset Speed 7	709	-1000.0	1000.0	70.0	Hz	0.01	Config	REAL
2.2.2.3.9	Preset Speed 8	710	-1000.0	1000.0	80.0	Hz	0.01	Config	REAL
2.2.2.3.10	Preset Speed Reference Bit 0 Input	711	0	29999	0		1	Config	UINT
2.2.2.3.11	Preset Speed Reference Bit 1 Input	712	0	29999	0		1	Config	UINT
2.2.2.3.12	Preset Speed Reference Bit 2 Input	713	0	29999	0		1	Config	UINT

6.3.2.2.4 Speed Reference Adjustment

Index	Name	Num	Min	Max	Default	Unit	Reso	Handling Type	Data Type
2.2.2.4.1	Adjustment Source Selection	4514	0	2	0		1	Config	UINT
2.2.2.4.2	Analog Adjustment Input	4515	0	29999	0		1	Config	UINT
2.2.2.4.3	Max. Speed Adjustment	4517	0.0	100.0	0.0	%	0.01	Config	REAL
2.2.2.4.4	Min. Speed Adjustment	4518	0.0	100.0	0.0	%	0.01	Config	REAL
2.2.2.4.5	Speed Step Adjustment	4519	-590.0	590.0	0.0	Hz	0.01	Config	REAL

6.3.2.2.5 Speed Bypass

Index	Name	Num	Min	Max	Default	Unit	Reso	Handling Type	Data Type
2.2.2.5.1	Band 1, Low Limit	4520	0.0	100.0	0.0	Hz	0.01	Config	REAL
2.2.2.5.2	Band 1, High Limit	4521	0.0	100.0	0.0	Hz	0.01	Config	REAL

Index	Name	Num	Min	Max	Default	Unit	Reso	Handling Type	Data Type
2.2.2.5.3	Band 2, Low Limit	4522	0.0	100.0	0.0	Hz	0.01	Config	REAL
2.2.2.5.4	Band 2, High Limit	4523	0.0	100.0	0.0	Hz	0.01	Config	REAL
2.2.2.5.5	Band 3, Low Limit	4524	0.0	100.0	0.0	Hz	0.01	Config	REAL
2.2.2.5.6	Band 3, High Limit	4525	0.0	100.0	0.0	Hz	0.01	Config	REAL
2.2.2.5.7	Band 4, Low Limit	4526	0.0	100.0	0.0	Hz	0.01	Config	REAL
2.2.2.5.8	Band 4, High Limit	4527	0.0	100.0	0.0	Hz	0.01	Config	REAL
2.2.2.5.9	Bypass Ramp Time	4528	0.0	10000.0	5.0	s	0.01	Config	REAL

6.3.2.3 Torque Reference

Index	Name	Num	Min	Max	Default	Unit	Reso	Handling Type	Data Type
2.2.3.1	I/O Torque Reference	1927	0	9	[3,0]		1	Config	UINT
2.2.3.2	I/O Torque Reference Logic	1917	0	7	0		1	Config	UINT
2.2.3.3	Fieldbus Torque Reference	1928	0	9	[2,0]		1	Config	UINT
2.2.3.4	Fieldbus Torque Reference Logic	1918	0	7	0		1	Config	UINT
2.2.3.5	Adv. Torque Reference	1929	0	9	[0,0]		1	Config	UINT
2.2.3.6	Adv. Torque Reference Logic	1919	0	7	0		1	Config	UINT
2.2.3.7	Local Torque Ref. Source	1925	1	9	1		1	Config	UINT
2.2.3.8	Local Torque Reference	6155	-300.0	300.0	0.0	%	0.01	Process	REAL
2.2.3.9	Torque Reference 1 Input	4534	0	29999	0		1	Config	UINT
2.2.3.10	Torque Reference 1 Max	4530	-300.0	300.0	100.0	%	0.01	Config	REAL
2.2.3.11	Torque Reference 1 Min	4531	-300.0	300.0	0.0	%	0.01	Config	REAL
2.2.3.12	Torque Reference 2 Input	1923	0	29999	0		1	Config	UINT
2.2.3.13	Torque Reference 2 Max	4532	-300.0	300.0	100.0	%	0.01	Config	REAL
2.2.3.14	Torque Reference 2 Min	4533	-300.0	300.0	0.0	%	0.01	Config	REAL
2.2.3.15	Torque Ref. 1 Input Failure Response	4595	0	2	0		1	Config	UINT
2.2.3.16	Torque Ref. 2 Input Failure Response	4596	0	2	0		1	Config	UINT
2.2.3.17	Torque Ref. Fieldbus Failure Response	4597	0	2	0		1	Config	UINT
2.2.3.18	Torque Ref. Failure Preset	4603	-300.0	300.0	0.0	%	1	Config	REAL
2.2.3.19	Torque Ref. Lowpass Filter Tc	2335	0.0	1000.0	0.0	ms	1	Config	REAL
2.2.3.20	Torque Reference Step	4542	-300.0	300.0	0.0	%	0.01	Process	REAL

6.3.2.4 Power Reference

Index	Name	Num	Min	Max	Default	Unit	Reso	Handling Type	Data Type
2.2.4.1	I/O Power Reference Source	1930	0	9	[3,0]		1	Config	UINT
2.2.4.2	I/O Power Reference Logic	1920	0	7	0		1	Config	UINT

Application Guide

Index	Name	Num	Min	Max	Default	Unit	Reso	Handling Type	Data Type
2.2.4.3	Fieldbus Power Reference Source	1931	0	9	[2,0]		1	Config	UINT
2.2.4.4	Fieldbus Power Reference Logic	1921	0	7	0		1	Config	UINT
2.2.4.5	Adv. Power Reference Source	1932	0	9	[0,0]		1	Config	UINT
2.2.4.6	Adv. Power Reference Logic	1922	0	7	0		1	Config	UINT
2.2.4.7	Local Power Reference Source	1926	1	9	1		1	Config	UINT
2.2.4.8	Power Reference 1 Input	4573	0	29999	0		1	Config	UINT
2.2.4.9	Power Reference 1 Max	4670	-300.0	300.0	100.0	%	1	Config	REAL
2.2.4.10	Power Reference 1 Min	4671	-300.0	300.0	0.0	%	1	Config	REAL
2.2.4.11	Power Reference 2 Input	1924	0	29999	0		1	Config	UINT
2.2.4.12	Power Reference 2 Max	4672	-300.0	300.0	100.0	%	1	Config	REAL
2.2.4.13	Power Reference 2 Min	4673	-300.0	300.0	0.0	%	1	Config	REAL
2.2.4.14	Power Ref. 1 Input Failure Response	4604	0	2	0		1	Config	UINT
2.2.4.15	Power Ref. 2 Input Failure Response	4605	0	2	0		1	Config	UINT
2.2.4.16	Power Ref. Fieldbus Failure Response	4606	0	2	0		1	Config	UINT
2.2.4.17	Power Ref. Failure Preset	4607	-300.0	300.0	0.0	%	0.01	Config	REAL
2.2.4.18	Control Panel Power Reference	4574	-300.0	300.0	0.0	%	0.01	Process	REAL

6.3.2.5 Joystick

Index	Name	Num	Min	Max	Default	Unit	Reso	Handling Type	Data Type
2.2.5.1	Joystick 1 Input	4500	0	29999	0		1	Config	UINT
2.2.5.2	Joystick 1 Max	4614	0.0	300.0	100.0	%	0.01	Config	REAL
2.2.5.3	Joystick 1 Min	4615	-300.0	0.0	-100.0	%	0.01	Config	REAL
2.2.5.4	Joystick 1 Deadband	4503	0.0	100.0	0.0	%	0.01	Config	REAL
2.2.5.5	Joystick 1 Sleep Window	4550	0.0	100.0	0.0	%	0.01	Config	REAL
2.2.5.6	Joystick 1 Sleep Delay	4552	0.0	320.0	0.0	s	0.01	Config	REAL
2.2.5.7	Joystick 1 Input Failure Response	4608	0	2	0		1	Config	UINT
2.2.5.8	Joystick 1 Failure Preset	4610	0.0	100.0	0.0	%	0.01	Config	REAL
2.2.5.9	Joystick 2 Input	4504	0	29999	0		1	Config	UINT
2.2.5.10	Joystick 2 Max	4616	0.0	300.0	100.0	%	0.01	Config	REAL
2.2.5.11	Joystick 2 Min	4617	-300.0	0.0	-100.0	%	0.01	Config	REAL
2.2.5.12	Joystick 2 Deadband	4507	0.0	100.0	0.0	%	0.01	Config	REAL
2.2.5.13	Joystick 2 Sleep Window	4551	0.0	100.0	0.0	%	0.01	Config	REAL
2.2.5.14	Joystick 2 Sleep Delay	4553	0.0	320.0	0.0	s	0.01	Config	REAL
2.2.5.15	Joystick 2 Input Failure	4609	0	2	0		1	Config	UINT

Index	Name	Num	Min	Max	Default	Unit	Reso	Handling Type	Data Type
	Response								
2.2.5.16	Joystick 2 Failure Preset	4611	0.0	100.0	0.0	%	0.01	Config	REAL

6.3.3 Limits

6.3.3.1 Speed Limits

Index	Name	Num	Min	Max	Default	Unit	Reso	Handling Type	Data Type
2.3.1.1	Positive Speed Limit	1729	0.0	3.4e+38	60.0	Hz	0.01	Config	REAL
2.3.1.2	Negative Speed Limit	1728	-3.4e+38	0.0	-60.0	Hz	0.01	Config	REAL
2.3.1.3	Minimum Speed Limit	1722	0.0	3.4e+38	0.0	Hz	0.01	Config	REAL
2.3.1.4	Positive Speed Ref. Limit 1	3210	0.0	1000.0	50.0	Hz	0.01	Config	REAL
2.3.1.5	Positive Speed Ref. Limit 2	3211	0.0	1000.0	35.0	Hz	0.01	Config	REAL
2.3.1.6	Positive Speed Ref. Limit Sel Input	3212	0	29999	0		1	Config	UINT
2.3.1.7	Negative Speed Ref. Limit 1	3213	-1000.0	0.0	-50.0	Hz	0.01	Config	REAL
2.3.1.8	Negative Speed Ref. Limit 2	3214	-1000.0	0.0	-35.0	Hz	0.01	Config	REAL
2.3.1.9	Negative Speed Ref. Limit Sel Input	3215	0	29999	0		1	Config	UINT
2.3.1.10	Speed Limit Mode Torque Control	2332	0	6	0		1	Config	UINT
2.3.1.11	Lower Window Limit	2333	0.0	10.0	0.0	Hz	0.01	Config	REAL
2.3.1.12	Upper Window Limit	2334	0.0	10.0	0.0	Hz	0.01	Config	REAL

6.3.3.2 Output Current Limit

Index	Name	Num	Min	Max	Default	Unit	Reso	Handling Type	Data Type
2.3.2.1	Motor Current Limit	3190	0.0	200.0	150.0	%	0.01	Config	REAL
2.3.2.2	Current Limiter Kp	3193	0.0	500.0	100.0	%	0.01	Config	REAL
2.3.2.3	Current Limiter Ti	3194	0.0	500.0	100.0	%	0.01	Config	REAL
2.3.2.4	Current Limit Scaling Select	3191	0	3	0		1	Config	UINT
2.3.2.5	Current Limit Scaling Input	3199	0	29999	0		1	Config	UINT
2.3.2.6	Current Limit Failure Response	5169	0	1	0		1	Config	BOOL
2.3.2.7	Current Limit Failure Preset	5170	0.0	200.0	100.0	%	0.01	Config	REAL

6.3.3.3 Torque Limits

Index	Name	Num	Min	Max	Default	Unit	Reso	Handling Type	Data Type
2.3.3.1	Positive Torque Limit	1810	0.0	500.0	300.0	%	0.01	Unspecified	REAL
2.3.3.2	Negative Torque Limit	1811	-500.0	0.0	-300.0	%	0.01	Unspecified	REAL
2.3.3.3	Motor Torque Limit	3156	0.0	300.0	300.0	%	0.01	Config	REAL

Index	Name	Num	Min	Max	Default	Unit	Reso	Handling Type	Data Type
2.3.3.4	Motor Torque Limit Scaling Sel.	3151	0	3	0		1	Config	UINT
2.3.3.5	Motor Torque Limit Scaling Input	3197	0	29999	0		1	Config	UINT
2.3.3.6	Motor Torque Limit Preset	3158	0.0	300.0	300.0	%	0.01	Config	REAL
2.3.3.7	Motor Torque Limit Preset Input	3150	0	29999	0		1	Config	UINT
2.3.3.8	Regenerative Torque Limit	3160	0.0	300.0	300.0	%	0.01	Config	REAL
2.3.3.9	Regenerative Torque Limit Scaling Sel.	3159	0	3	0		1	Config	UINT
2.3.3.10	Regenerative Torque Limit Scaling Input	3198	0	29999	0		1	Config	UINT
2.3.3.11	Regenerative Torque Limit Preset	3163	0.0	300.0	300.0	%	0.01	Config	REAL
2.3.3.12	Regenerative Torque Limit Preset Input	3162	0	29999	0		1	Config	UINT
2.3.3.13	Torque Follower Mode	3154	0	3	0		1	Config	UINT
2.3.3.14	Torque Follower Hysteresis	3152	0.0	300.0	10.0	%	0.01	Config	REAL
2.3.3.15	Motor Torque Limit Failure Response	5171	0	1	0		1	Config	BOOL
2.3.3.16	Motor Torque Limit Failure Preset	5172	0.0	300.0	300.0	%	0.01	Config	REAL
2.3.3.17	Regen. Torque Limit Failure Response	5233	0	1	0		1	Config	BOOL
2.3.3.18	Regen. Torque Limit Failure Preset	5234	0.0	300.0	300.0	%	0.01	Config	REAL
2.3.3.19	Positive Torque Ref. Limit	4630	0.0	300.0	100.0	%	0.01	Config	REAL
2.3.3.20	Negative Torque Ref. Limit	4631	-300.0	0.0	-100.0	%	0.01	Config	REAL

6.3.3.4 Power Limits

Index	Name	Num	Min	Max	Default	Unit	Reso	Handling Type	Data Type
2.3.4.1	Overall Power Limit	3165	0.0	300.0	300.0	%	0.01	Config	REAL
2.3.4.2	Motor Power Limit	3167	0.0	300.0	300.0	%	0.01	Config	REAL
2.3.4.3	Motor Power Limit Scaling Sel.	3185	0	3	0		1	Config	UINT
2.3.4.4	Motor Power Limit Scaling Input	3195	0	29999	0		1	Config	UINT
2.3.4.5	Motor Power Limit Preset 1	3170	0.0	300.0	100.0	%	0.01	Config	REAL
2.3.4.6	Motor Power Limit Preset 2	3171	0.0	300.0	50.0	%	0.01	Config	REAL
2.3.4.7	Motor Power Limit Preset Input 1	3179	0	29999	0		1	Config	UINT
2.3.4.8	Motor Power Limit Preset Input 2	3181	0	29999	0		1	Config	UINT
2.3.4.9	Regenerative Power Limit	3166	0.0	300.0	300.0	%	0.01	Config	REAL

Index	Name	Num	Min	Max	Default	Unit	Reso	Handling Type	Data Type
2.3.4.10	Regenerative Power Limit Scaling Sel.	3186	0	3	0		1	Config	UINT
2.3.4.11	Regenerative Power Limit Scaling Input	3196	0	29999	0		1	Config	UINT
2.3.4.12	Regenerative Power Limit Preset 1	3168	0.0	300.0	100.0	%	0.01	Config	REAL
2.3.4.13	Regenerative Power Limit Preset 2	3169	0.0	300.0	50.0	%	0.01	Config	REAL
2.3.4.14	Regenerative Power Limit Preset Input 1	3180	0	29999	0		1	Config	UINT
2.3.4.15	Regenerative Power Limit Preset Input 2	3182	0	29999	0		1	Config	UINT
2.3.4.16	Power Follower Mode	3173	0	1	0		1	Config	BOOL
2.3.4.17	Power Follower Hysteresis	3174	0.0	100.0	10.0	%	0.01	Config	REAL
2.3.4.18	Undervoltage Limit for Power Limit	3177	0.0	1200.0	0.0	V	0.01	Config	REAL
2.3.4.19	Undervoltage Power Limit Preset	3178	0.0	300.0	0.0	%	0.01	Config	REAL
2.3.4.20	Motor Power Limit Failure Response	5173	0	1	0		1	Config	BOOL
2.3.4.21	Motor Power Limit Failure Preset	5174	0.0	300.0	300.0	%	0.01	Config	REAL
2.3.4.22	Regen. Power Limit Failure Response	5168	0	1	0		1	Config	BOOL
2.3.4.23	Regen. Power Limit Failure Preset	5248	0.0	300.0	300.0		0.01	Config	REAL
2.3.4.24	Positive Power Ref. Limit	4571	0.0	300.0	100.0	%	0.01	Config	REAL
2.3.4.25	Negative Power Ref. Limit	8027	-300.0	0.0	-100.0	%	0.01	Config	REAL

6.3.3.5 DC-Link Voltage Limiters

6.3.3.5.1 Undervoltage Limit Controller

Index	Name	Num	Min	Max	Default	Unit	Reso	Handling Type	Data Type
2.3.5.1.1	Undervoltage Response	1818	0	3	1		1	Config	UINT
2.3.5.1.2	Undervoltage Recovery Response	1819	0	20	0		1	Config	UINT
2.3.5.1.3	Undervoltage Control Kp	1806	0.001	10000.0	100.0	%	0.01	Unspecified	REAL
2.3.5.1.4	Undervoltage Control Ti	1807	0.0	10000.0	100.0	%	0.01	Unspecified	REAL
2.3.5.1.5	Undervoltage Control Td	1808	0.0	10000.0	100.0	%	0.01	Unspecified	REAL
2.3.5.1.6	Undervoltage Limit Source	2900	0	1	0		1	Config	UINT
2.3.5.1.7	Undervoltage Limit	2901	0.0	320.0	79.0	%	0.01	Config	REAL
2.3.5.1.8	UV Limit Failure Response	4502	0	1	0		1	Config	BOOL
2.3.5.1.9	UV Limit Failure Preset	2948	0	320.0	70.0	%	0.01	Config	REAL
2.3.5.1.10	Deceleration Time Power Loss	1139	0.02	10000.0	0.5	s	0.01	Config	REAL

6.3.3.5.2 Overvoltage Limit Controller

Index	Name	Num	Min	Max	Default	Unit	Reso	Handling Type	Data Type
2.3.5.2.1	Overvoltage Control	1802	0	1	1		1	Config	BOOL
2.3.5.2.2	Overvoltage Control Kp	1803	0.0	10000.0	100.0	%	0.01	Config	REAL
2.3.5.2.3	Overvoltage Control Ti	1804	0.0	10000.0	100.0	%	0.01	Config	REAL
2.3.5.2.4	Overvoltage Control Td	1805	0.0	10000.0	100.0	%	0.01	Config	REAL
2.3.5.2.5	Overvoltage Limit Source	2897	0	1	0		1	Config	UINT
2.3.5.2.6	Overvoltage Limit	2898	0.0	320.0	112.0	%	0.01	Config	REAL
2.3.5.2.7	OV Limit Failure Response	4501	0	1	0		1	Config	BOOL
2.3.5.2.8	OV Limit Failure Preset	2911	0	320.0	120.0	%	0.01	Config	REAL

6.3.3.5.3 Brake Chopper

Index	Name	Num	Min	Max	Default	Unit	Reso	Handling Type	Data Type
2.3.5.3.1	Brake Chopper	2935	0	2	0		1	Config	UINT
2.3.5.3.2	Brake Chopper Voltage Reduce	2938	0.0	50.0	0.0	V	0.01	Config	REAL
2.3.5.3.3	Brake Resistor Resistance	2936	-3.4e+38	3.4e+38	5.0	Ω	0.01	Config	REAL
2.3.5.3.4	Brake Resistor Power Limit	2937	0.0	3.4e+38	1.0	kW	0.01	Config	REAL
2.3.5.3.5	Brake Resistor Test	430	0	1	0		1	Process	UINT

6.3.3.5.4 DC Voltage Drooping

Index	Name	Num	Min	Max	Default	Unit	Reso	Handling Type	Data Type
2.3.5.4.1	DC Voltage Drooping Mode	4619	0	1	0		1	Config	UINT
2.3.5.4.2	DC-link Voltage Droop Gain	2912	0.0	100.0	0.0	%	0.01	Unspecified	REAL
2.3.5.4.3	DC-link Voltage Droop. Tc	5095	0.0	1.0	0.05	s	0.001	Config	REAL

6.3.4 Ramps

6.3.4.1 Speed Ramps

6.3.4.1.1 Speed Ramp Settings

Index	Name	Num	Min	Max	Default	Unit	Reso	Handling Type	Data Type
2.4.1.1.1	Speed Ramp Selection Input	1130	0	29999	0		1	Config	UINT
2.4.1.1.2	Enable Speed Ramp Gap	5504	0	1	1		1	Config	BOOL
2.4.1.1.3	Speed Ramp Gap	5505	0.0	100.0	3.0	Hz	0.01	Config	REAL

6.3.4.1.2 Ramp 1

Index	Name	Num	Min	Max	Default	Unit	Reso	Handling Type	Data Type
2.4.1.2.1	Ramp 1 Accel. Time	1101	0.0	10000.0	5.0	s	0.01	Config	REAL
2.4.1.2.2	Ramp 1 Decel. Time	1105	0.0	10000.0	5.0	s	0.01	Config	REAL
2.4.1.2.3	S-Ramp 1 Accel. Increase Time	1109	0.0	10000.0	0.0	s	0.01	Config	REAL
2.4.1.2.4	S-Ramp 1 Accel. Decrease Time	1113	0.0	10000.0	0.0	s	0.01	Config	REAL
2.4.1.2.5	S-Ramp 1 Decel. Increase Time	1117	0.0	10000.0	0.0	s	0.01	Config	REAL
2.4.1.2.6	S-Ramp 1 Decel. Decrease Time	1121	0.0	10000.0	0.0	s	0.01	Config	REAL

6.3.4.1.3 Ramp 2

Index	Name	Num	Min	Max	Default	Unit	Reso	Handling Type	Data Type
2.4.1.3.1	Ramp 2 Accel. Time	1106	0.0	10000.0	10.0	s	0.01	Config	REAL
2.4.1.3.2	Ramp 2 Decel. Time	1102	0.0	10000.0	10.0	s	0.01	Config	REAL
2.4.1.3.3	S-Ramp 2 Accel. Increase Time	1110	0.0	10000.0	0.0	s	0.01	Config	REAL
2.4.1.3.4	S-Ramp 2 Accel. Decrease Time	1114	0.0	10000.0	0.0	s	0.01	Config	REAL
2.4.1.3.5	S-Ramp 2 Decel. Increase Time	1118	0.0	10000.0	0.0	s	0.01	Config	REAL
2.4.1.3.6	S-Ramp 2 Decel. Decrease Time	1122	0.0	10000.0	0.0	s	0.01	Config	REAL

6.3.4.2 Torque Ramp

Index	Name	Num	Min	Max	Default	Unit	Reso	Handling Type	Data Type
2.4.2.1	Torque Ref. Increase Rate	2350	0.0	1000.0	10.0	%/s	0.01	Config	REAL
2.4.2.2	Torque Ref. Decrease Rate	2351	0.0	1000.0	10.0	%/s	0.01	Config	REAL
2.4.2.3	Torque Ref. Ramp Rate Source	2352	0	1	0		1	Config	UINT
2.4.2.4	Torque Limit Increase Rate	3153	0.0	10000.0	10.0	%/s	0.01	Config	REAL

6.3.4.3 Power Ramp

Index	Name	Num	Min	Max	Default	Unit	Reso	Handling Type	Data Type
2.4.3.1	Power Ref. Increase Rate	4572	0.0	10000.0	10.0	%/s	0.01	Config	REAL
2.4.3.2	Power Ref. Decrease Rate	4576	0.0	10000.0	0.0	%/s	0.01	Config	REAL
2.4.3.3	Power Ref. Ramp Rate Source	4577	0	1	0		1	Config	UINT
2.4.3.4	Power Limit Increase Rate	3172	0.0	10000.0	10.0	%/s	0.01	Config	REAL
2.4.3.5	Power Limit Ramp Rate Source	3200	0	1	0		1	Config	UINT

6.3.5 Digital and Analog Inputs

6.3.5.1 Digital Inputs

Index	Name	Num	Min	Max	Default	Unit	Reso	Handling Type	Data Type
2.5.1.1	I/O Start Forward Input	200	0	29999	10113		1	Config	UINT
2.5.1.2	I/O Start Backward Input	210	0	29999	0		1	Config	UINT
2.5.1.3	I/O Ramp Stop Inverse Input	201	0	29999	10114		1	Config	UINT
2.5.1.4	I/O Coast Inverse Input	202	0	29999	1		1	Config	UINT
2.5.1.5	I/O Reset Input	203	0	29999	10117		1	Config	UINT
2.5.1.6	I/O Reverse Input	204	0	29999	10116		1	Config	UINT
2.5.1.7	Advanced Start Forward Input	4722	0	29999	[0,0]		1	Config	UINT
2.5.1.8	Advanced Start Backward Input	4725	0	29999	[0,0]		1	Config	UINT
2.5.1.9	Adv. Ramp Stop Inverse Input	4723	0	29999	[1,1]		1	Config	UINT
2.5.1.10	Advanced Coast Inverse Input	4724	0	29999	[1,1]		1	Config	UINT
2.5.1.11	Advanced Reset Input	4731	0	29999	[0,0]		1	Config	UINT
2.5.1.12	Advanced Reversing Input	4730	0	29999	[0,0]		1	Config	UINT
2.5.1.13	Run Enable Input	103	0	29999	1		1	Config	UINT
2.5.1.14	Quick Stop Input	215	0	29999	0		1	Config	UINT
2.5.1.15	Quick Stop Inverse Input	4601	0	29999	1		1	Config	UINT
2.5.1.16	Run Interlock Input 1	4715	0	29999	1		1	Config	UINT
2.5.1.17	Run Interlock Input 2	4716	0	29999	1		1	Config	UINT
2.5.1.18	Start Interlock Input 1	4713	0	29999	1		1	Config	UINT
2.5.1.19	Start Interlock Input 2	4714	0	29999	1		1	Config	UINT
2.5.1.20	Breaker Control Enable Input	4735	0	29999	0		1	Config	UINT
2.5.1.21	Breaker Manual Close Input	4705	0	29999	0		1	Config	UINT
2.5.1.22	Breaker Manual Open Input	4706	0	29999	0		1	Config	UINT
2.5.1.23	Breaker Close Feedback Input	4707	0	29999	0		1	Config	UINT
2.5.1.24	Breaker Open Feedback Input	4708	0	29999	0		1	Config	UINT
2.5.1.25	Brake Closed Input	3011	0	29999	0		1	Config	UINT
2.5.1.26	Brake Open Input	3010	0	29999	0		1	Config	UINT
2.5.1.27	Enable Inching Input	1080	0	29999	1		1	Config	UINT
2.5.1.28	Inching Activate Input 1	1084	0	29999	0		1	Config	UINT
2.5.1.29	Inching Activate Input 2	1086	0	29999	0		1	Config	UINT
2.5.1.30	Freeze Input	1008	0	29999	0		1	Config	UINT
2.5.1.31	Freeze Up Input	1001	0	29999	0		1	Config	UINT
2.5.1.32	Freeze Down Input	1002	0	29999	0		1	Config	UINT
2.5.1.33	Preset Speed Reference Bit 0	711	0	29999	0		1	Config	UINT

Application Guide

Index	Name	Num	Min	Max	Default	Unit	Reso	Handling Type	Data Type
	Input								
2.5.1.34	Preset Speed Reference Bit 1 Input	712	0	29999	0		1	Config	UINT
2.5.1.35	Preset Speed Reference Bit 2 Input	713	0	29999	0		1	Config	UINT
2.5.1.36	Motor Torque Limit Preset Input	3150	0	29999	0		1	Config	UINT
2.5.1.37	Regenerative Torque Limit Preset Input	3162	0	29999	0		1	Config	UINT
2.5.1.38	Motor Power Limit Preset Input 1	3179	0	29999	0		1	Config	UINT
2.5.1.39	Motor Power Limit Preset Input 2	3181	0	29999	0		1	Config	UINT
2.5.1.40	Regenerative Power Limit Preset Input 1	3180	0	29999	0		1	Config	UINT
2.5.1.41	Regenerative Power Limit Preset Input 2	3182	0	29999	0		1	Config	UINT
2.5.1.42	Control Mode Preset Input 1	3469	0	29999	0		1	Config	UINT
2.5.1.43	Control Mode Preset Input 2	3470	0	29999	0		1	Config	UINT
2.5.1.44	I/O Speed Reference Toggle Input	1940	0	29999	0		1	Config	UINT
2.5.1.45	Fieldbus Speed Reference Toggle Input	1939	0	29999	0		1	Config	UINT
2.5.1.46	Adv. Speed Reference Toggle Input	1941	0	29999	0		1	Config	UINT
2.5.1.47	Speed Ramp Selection Input	1130	0	29999	0		1	Config	UINT
2.5.1.48	Load Drooping Assist Force Off Input	4585	0	29999	0		1	Config	UINT
2.5.1.49	External Event 1 Input	4557	0	29999	0		1	Config	UINT
2.5.1.50	Ext. Event 1 Inverse Input	4558	0	29999	1		1	Config	UINT
2.5.1.51	External Event 2 Input	4560	0	29999	0		1	Config	UINT
2.5.1.52	Ext. Event 2 Inverse Input	4561	0	29999	1		1	Config	UINT
2.5.1.53	Cooling Monitor Input	2400	0	29999	1		1	Config	UINT
2.5.1.54	Positive Speed Ref. Limit Sel Input	3212	0	29999	0		1	Config	UINT
2.5.1.55	Negative Speed Ref. Limit Sel Input	3215	0	29999	0		1	Config	UINT
2.5.1.56	Force I/O Control Input	4513	0	29999	0		1	Config	UINT
2.5.1.57	Force FB Control Input	4511	0	29999	0		1	Config	UINT
2.5.1.58	Force Advanced Control Input	4721	0	29999	0		1	Config	UINT
2.5.1.59	Thermal Switch Input	3414	0	29999	0		1	Config	UINT

6.3.5.2 Analog Inputs

Index	Name	Num	Min	Max	Default	Unit	Reso	Handling Type	Data Type
2.5.2.1	Speed Reference 1 Input	501	0	29999	10133		1	Config	UINT
2.5.2.2	Speed Reference 2 Input	502	0	29999	10134		1	Config	UINT
2.5.2.3	Analog Adjustment Input	4515	0	29999	0		1	Config	UINT
2.5.2.4	Torque Reference 1 Input	4534	0	29999	0		1	Config	UINT
2.5.2.5	Torque Reference 2 Input	1923	0	29999	0		1	Config	UINT
2.5.2.6	Power Reference 1 Input	4573	0	29999	0		1	Config	UINT
2.5.2.7	Power Reference 2 Input	1924	0	29999	0		1	Config	UINT
2.5.2.8	Joystick 1 Input	4500	0	29999	0		1	Config	UINT
2.5.2.9	Joystick 2 Input	4504	0	29999	0		1	Config	UINT
2.5.2.10	Current Limit Scaling Input	3199	0	29999	0		1	Config	UINT
2.5.2.11	Motor Torque Limit Scaling Input	3197	0	29999	0		1	Config	UINT
2.5.2.12	Regenerative Torque Limit Scaling Input	3198	0	29999	0		1	Config	UINT
2.5.2.13	Motor Power Limit Scaling Input	3195	0	29999	0		1	Config	UINT
2.5.2.14	Regenerative Power Limit Scaling Input	3196	0	29999	0		1	Config	UINT
2.5.2.15	Load Drooping Assist Analog Input	4583	0	29999	0		1	Config	UINT

6.3.6 Digital and Analog Outputs

6.3.6.1 Digital Outputs

Index	Name	Num	Min	Max	Default	Unit	Reso	Handling Type	Data Type
2.6.1.1	Ready Output	205	0	29999	10102		1	Config	UINT
2.6.1.2	Run Output	206	0	29999	10105		1	Config	UINT
2.6.1.3	On Reference Output	207	0	29999	0		1	Config	UINT
2.6.1.4	Static Fault Output	208	0	29999	10108		1	Config	UINT
2.6.1.5	Static Warning Output	209	0	29999	0		1	Config	UINT
2.6.1.6	Reverse Output	5175	0	29999	0		1	Config	UINT
2.6.1.7	Wrong Direction Output	5176	0	29999	0		1	Config	UINT
2.6.1.8	Toggling Fault Output	5180	0	29999	0		1	Config	UINT
2.6.1.9	Toggling Warning Output	5181	0	29999	0		1	Config	UINT
2.6.1.10	Regulator Active Output	5182	0	29999	0		1	Config	UINT
2.6.1.11	Drive Overheat Output	5183	0	29999	0		1	Config	UINT
2.6.1.12	FB CTW Bit 12 Output	5193	0	29999	0		1	Config	UINT
2.6.1.13	FB CTW Bit 13 Output	5194	0	29999	0		1	Config	UINT
2.6.1.14	FB CTW Bit 14 Output	5198	0	29999	0		1	Config	UINT
2.6.1.15	FB CTW Bit 15 Output	5191	0	29999	0		1	Config	UINT

Index	Name	Num	Min	Max	Default	Unit	Reso	Handling Type	Data Type
2.6.1.16	Local Control Active Output	5178	0	29999	0		1	Config	UINT
2.6.1.17	I/O Control Active Output	5177	0	29999	0		1	Config	UINT
2.6.1.18	Fieldbus Control Active Output	5197	0	29999	0		1	Config	UINT
2.6.1.19	Advanced Control Active Output	4727	0	29999	0		1	Config	UINT
2.6.1.20	Local Control Forcing Requested Output	125	0	29999	0		1	Config	UINT
2.6.1.21	I/O Forcing Requested Output	121	0	29999	0		1	Config	UINT
2.6.1.22	FB Forcing Requested Output	120	0	29999	0		1	Config	UINT
2.6.1.23	Advanced Forcing Requested Output	122	0	29999	0		1	Config	UINT
2.6.1.24	Motoring Power Limited Output	219	0	29999	0		1	Config	UINT
2.6.1.25	Brake Output	3007	0	29999	0		1	Config	UINT
2.6.1.26	Breaker Close Output	4709	0	29999	0		1	Config	UINT
2.6.1.27	Breaker Open Output	4710	0	29999	0		1	Config	UINT
2.6.1.28	Capacitor Disconnect Output	3412	0	29999	0		1	Config	UINT
2.6.1.29	Persistent Warning Output	126	0	29999	0		1	Config	UINT
2.6.1.30	Regenerative Power Limited Output	223	0	29999	0		1	Config	UINT
2.6.1.31	Freeze Up Output	2442	0	29999	0		1	Config	UINT
2.6.1.32	Freeze Down Output	2443	0	29999	0		1	Config	UINT
2.6.1.33	Reset Output	2444	0	29999	0		1	Config	UINT

6.3.6.2 Delayed Digital Outputs

Index	Name	Num	Min	Max	Default	Unit	Reso	Handling Type	Data Type
2.6.2.1	Delayed Output 1 Content Sel.	8032	0	34	0		1	Config	UINT
2.6.2.2	Output 1 Inversion	8034	0	1	0		1	Config	BOOL
2.6.2.3	Delayed Output 1 On Delay	8036	0.0	320.0	0.0	s	0.01	Config	REAL
2.6.2.4	Delayed Output 1 Off Delay	8038	0.0	320.0	0.0	s	0.01	Config	REAL
2.6.2.5	Delayed Output 1 Output	8040	0	29999	0		1	Config	UINT
2.6.2.6	Delayed Output 2 Content Sel.	8033	0	34	0		1	Config	UINT
2.6.2.7	Output 2 Inversion	8035	0	1	0		1	Config	BOOL
2.6.2.8	Delayed Output 2 On Delay	8037	0.0	320.0	0.0	s	0.01	Config	REAL
2.6.2.9	Delayed Output 2 Off Delay	8039	0.0	320.0	0.0	s	0.01	Config	REAL
2.6.2.10	Delayed Output 2 Output	8041	0	29999	0		1	Config	UINT

6.3.6.3 Analog outputs

Index	Name	Num	Min	Max	Default	Unit	Reso	Handling Type	Data Type
2.6.3.1	Drive DC-link Voltage Output	2311	0	29999	0		1	Config	UINT
2.6.3.2	Heat Sink Temperature Output	2312	0	29999	0		1	Config	UINT
2.6.3.3	Absolute Output Frequency Output	2300	0	29999	10131		1	Config	UINT
2.6.3.4	Motor Current Output	2302	0	29999	0		1	Config	UINT
2.6.3.5	Motor Power Output	2305	0	29999	0		1	Config	UINT
2.6.3.6	Absolute Motor Torque Output	2306	0	29999	0		1	Config	UINT
2.6.3.7	Extended Motor Torque Output	2310	0	29999	0		1	Config	UINT
2.6.3.8	Absolute Motor Speed Output	2301	0	29999	0		1	Config	UINT
2.6.3.9	Extended Motor Speed Output	2309	0	29999	0		1	Config	UINT
2.6.3.10	Motor Voltage Output	2303	0	29999	0		1	Config	UINT
2.6.3.11	Absolute Speed Reference Output	2304	0	29999	0		1	Config	UINT
2.6.3.12	Output Frequency Output	2308	0	29999	0		1	Config	UINT
2.6.3.13	Scaled Motor Speed Output	2430	0	29999	0		1	Config	UINT
2.6.3.14	Scaled Motor Speed Output Max.	2431	-100000	100000	1500	rpm	0.01	Config	REAL
2.6.3.15	Scaled Motor Speed Output Min.	2432	-100000	100000	-1500	rpm	0.01	Config	REAL
2.6.3.16	Scaled Speed Reference Output	2433	0	29999	0		1	Config	UINT
2.6.3.17	Scaled Speed Reference Output Max.	2434	-2000	2000	100	Hz	0.01	Config	REAL
2.6.3.18	Scaled Speed Reference Output Min.	2435	-2000	2000	-100	Hz	0.01	Config	REAL
2.6.3.19	Scaled Motor Power Output	2439	0	29999	0		1	Config	UINT
2.6.3.20	Scaled Motor Power Output Max.	2440	-100000	100000	100	kW	0.01	Config	REAL
2.6.3.21	Scaled Motor Power Output Min.	2441	-100000	100000	-100	kW	0.01	Config	REAL
2.6.3.22	Scaled Motor Torque % Output	2436	0	29999	0		1	Config	UINT
2.6.3.23	Scaled Motor Torque % Output Max.	2437	-300	300	100	%	0.01	Config	REAL
2.6.3.24	Scaled Motor Torque % Output Min.	2438	-300	300	-100	%	0.01	Config	REAL

6.3.7 Start and Stop Settings

6.3.7.1 Start Settings

Index	Name	Num	Min	Max	Default	Unit	Reso	Handling Type	Data Type
2.7.1.1	Magnetization Time	2328	-1.0	10000.0	-1.0	s	0.01	Config	REAL
2.7.1.2	Flying Start	4025	0	1	0		1	Config	BOOL
2.7.1.3	Missing Start Response	4717	0	1	1		1	Config	UINT
2.7.1.4	Start Delay	4743	0.0	100.0	0.0	s	0.01	Config	REAL
2.7.1.5	Run Enable Input	103	0	29999	1		1	Config	UINT
2.7.1.6	Start Blocked Response	5110	0	3	1		1	Config	UINT
2.7.1.7	Flying Start Method	4621	0	1	0		1	Config	UINT
2.7.1.8	Flying Start Search Direction	4622	0	1	0		1	Config	UINT

6.3.7.2 DC Start

Index	Name	Num	Min	Max	Default	Unit	Reso	Handling Type	Data Type
2.7.2.1	DC Start Time	2264	0.0	10000.0	0.0	s	0.01	Config	REAL
2.7.2.2	DC Start Current Rise Time	2265	0.0	100.0	0.0	s	0.01	Config	REAL
2.7.2.3	DC Start Current	2263	0.0	1000.0	0.0	%	0.01	Config	REAL

6.3.7.3 Synchronous Motor Start

Index	Name	Num	Min	Max	Default	Unit	Reso	Handling Type	Data Type
2.7.3.1	Sync. Motor Start Mode	2322	0	2	1		1	Config	UINT
2.7.3.2	Sync. Motor Detection Current	2323	0.0	200.0	150.0	%	0.01	Config	REAL
2.7.3.3	Sync. Motor Parking Time	2324	0.0	10000.0	3.0	s	0.01	Config	REAL
2.7.3.4	Sync. Motor Parking Current	2325	0.0	1000.0	100.0	%	0.01	Config	REAL
2.7.3.5	Sync. Motor Parking Angle	2326	0.0	360.0	0.0	°	0.01	Config	REAL

6.3.7.4 Stop Settings

Index	Name	Num	Min	Max	Default	Unit	Reso	Handling Type	Data Type
2.7.4.1	Stop Zero Speed Time	2331	-1.0	10000.0	0.0	s	0.01	Config	REAL
2.7.4.2	Zero-speed Detection Level	2339	0.0	2.0	0.2	Hz	0.01	Config	REAL
2.7.4.3	Zero-speed Detection Delay	2356	0.0	2.0	0.02	s	0.01	Config	REAL

6.3.7.5 DC Injection

Index	Name	Num	Min	Max	Default	Unit	Reso	Handling Type	Data Type
2.7.5.1	DC-brake Time	2267	0.0	10000.0	0.0	s	0.01	Config	REAL
2.7.5.2	DC-brake Current	2266	0.0	1000.0	0.0	%	0.01	Config	REAL

Index	Name	Num	Min	Max	Default	Unit	Reso	Handling Type	Data Type
2.7.5.3	DC-brake Speed	2268	0.0	3.4e+38	0.0	Hz	0.01	Config	REAL
2.7.5.4	DC Stop Time	2320	-1.0	10000.0	0.0	s	0.01	Config	REAL
2.7.5.5	DC Stop Current	2321	0.0	1000.0	0.0	%	0.01	Config	REAL

6.3.7.6 Quick Stop

Index	Name	Num	Min	Max	Default	Unit	Reso	Handling Type	Data Type
2.7.6.1	Quick Stop Input	215	0	29999	0		1	Config	UINT
2.7.6.2	Quick Stop Ramp Time	1129	0.0	10000.0	1.0	s	0.01	Config	REAL
2.7.6.3	Quick Stop Mode	4588	0	3	1		1	Config	UINT
2.7.6.4	Quick Stop Response	4587	0	12	12		1	Config	UINT
2.7.6.5	Quick Stop Active Output	5179	0	29999	0		1	Config	UINT
2.7.6.6	Quick Stop Inverse Input	4601	0	29999	1		1	Config	UINT
2.7.6.7	Quick Stop Torque Ramp Rate	4590	0.0	1000.0	1000.0	%/s	0.01	Config	REAL
2.7.6.8	Quick Stop Power Ramp Rate	4613	0.0	1000.0	1000.0	%/s	0.01	Config	REAL

6.3.7.7 AC Brake

Index	Name	Num	Min	Max	Default	Unit	Reso	Handling Type	Data Type
2.7.7.1	AC Brake	4026	0	1	0		1	Config	BOOL
2.7.7.2	AC-brake Voltage Control Kp	4027	0.0	500.0	100.0	%	0.01	Config	REAL
2.7.7.3	AC-brake Voltage Control Ti	4028	0.0	500.0	100.0	%	0.01	Config	REAL
2.7.7.4	AC-brake Current	4057	0.0	150.0	100.0	%	0.01	Config	REAL

6.3.7.8 Interlocking

Index	Name	Num	Min	Max	Default	Unit	Reso	Handling Type	Data Type
2.7.8.1	Start Interlock Input 1	4713	0	29999	1		1	Config	UINT
2.7.8.2	Start Interlock Input 2	4714	0	29999	1		1	Config	UINT
2.7.8.3	Run Interlock Input 1	4715	0	29999	1		1	Config	UINT
2.7.8.4	Run Interlock Input 2	4716	0	29999	1		1	Config	UINT
2.7.8.5	Interlocking Response	4719	0	3	0		1	Config	UINT
2.7.8.6	Interlocking Response Delay	4720	0.0	120.0	0.0	s	0.01	Config	REAL

6.3.8 Control Places

6.3.8.1 Control Place Settings

Index	Name	Num	Min	Max	Default	Unit	Reso	Handling Type	Data Type
2.8.1.1	Control Place Selection	114	1	4	3		1	Config	UINT

Index	Name	Num	Min	Max	Default	Unit	Reso	Handling Type	Data Type
2.8.1.2	Force FB Control Input	4511	0	29999	0		1	Config	UINT
2.8.1.3	Force I/O Control Input	4513	0	29999	0		1	Config	UINT
2.8.1.4	Force Advanced Control Input	4721	0	29999	0		1	Config	UINT
2.8.1.5	Control Place Forcing Mode	1972	0	7	0		1	Config	UINT
2.8.1.6	Control Place Independent Reset	109	0	1	1		1	Config	BOOL
2.8.1.7	Control Place Release Mode	4800	0	1	1		1	Config	BOOL
2.8.1.8	Control Place Forcing Priority	4732	1	4	[1,4,3,2]		1	Config	UINT
2.8.1.9	Continue Operation in PC Control	105	0	1	0		1	Config	BOOL
2.8.1.10	Continue Operation in Local Control	108	0	1	1		1	Config	BOOL
2.8.1.11	Continue Operation in Fieldbus Control	5112	0	1	1		1	Config	BOOL
2.8.1.12	Continue Operation in I/O Control	5111	0	1	0		1	Config	BOOL
2.8.1.13	Continue Operation in Adv. Control	5113	0	1	0		1	Config	BOOL

6.3.8.2 Local Control

Index	Name	Num	Min	Max	Default	Unit	Reso	Handling Type	Data Type
2.8.2.1	Allow Local Control Force Stop	106	0	1	1		1	Config	BOOL
2.8.2.2	Local Control Mode	107	0	2	0		1	Config	UINT
2.8.2.3	Local Control Stop Button Action	110	0	2	2		1	Config	UINT

6.3.8.3 I/O Control

Index	Name	Num	Min	Max	Default	Unit	Reso	Handling Type	Data Type
2.8.3.1	I/O Start Forward Input	200	0	29999	10113		1	Config	UINT
2.8.3.2	I/O Start Backward Input	210	0	29999	0		1	Config	UINT
2.8.3.3	I/O Ramp Stop Inverse Input	201	0	29999	10114		1	Config	UINT
2.8.3.4	I/O Coast Inverse Input	202	0	29999	1		1	Config	UINT
2.8.3.5	I/O Reverse Input	204	0	29999	10116		1	Config	UINT
2.8.3.6	I/O Reset Input	203	0	29999	10117		1	Config	UINT
2.8.3.7	I/O Start Mode	214	0	2	0		1	Config	UINT

6.3.8.4 Fieldbus Control

Index	Name	Num	Min	Max	Default	Unit	Reso	Handling Type	Data Type
2.8.4.1	Fieldbus Profile	1301	0	65535	0		1	Config	UINT

6.3.8.5 Advanced control

Index	Name	Num	Min	Max	Default	Unit	Reso	Handling Type	Data Type
2.8.5.1	Advanced Start Forward Input	4722	0	29999	[0,0]		1	Config	UINT
2.8.5.2	Advanced Start Forward Logic	1933	0	7	0		1	Config	UINT
2.8.5.3	Advanced Start Backward Input	4725	0	29999	[0,0]		1	Config	UINT
2.8.5.4	Advanced Start Backward Logic	1934	0	7	0		1	Config	UINT
2.8.5.5	Adv. Ramp Stop Inverse Input	4723	0	29999	[1,1]		1	Config	UINT
2.8.5.6	Adv. Ramp Stop Inverse Logic	1935	0	7	0		1	Config	UINT
2.8.5.7	Advanced Coast Inverse Input	4724	0	29999	[1,1]		1	Config	UINT
2.8.5.8	Advanced Coast Inverse Logic	1936	0	7	0		1	Config	UINT
2.8.5.9	Advanced Reversing Input	4730	0	29999	[0,0]		1	Config	UINT
2.8.5.10	Advanced Reverse Logic	1937	0	7	0		1	Config	UINT
2.8.5.11	Advanced Reset Input	4731	0	29999	[0,0]		1	Config	UINT
2.8.5.12	Advanced Start Mode	4726	0	2	0		1	Config	UINT
2.8.5.13	Fieldbus CTW Feature Bits	4627	0	1	0		1	Config	BOOL

6.3.9 Motor Control

6.3.9.1 General Settings

Index	Name	Num	Min	Max	Default	Unit	Reso	Handling Type	Data Type
2.9.1.1	AMA Mode	420	0	4	0		1	Process	UINT
2.9.1.2	Motor Control Principle	2503	0	65535	0		1	Config	UINT
2.9.1.3	Breakaway Current Boost	2930	0	1	0		1	Config	BOOL
2.9.1.4	Number of Pole Pairs	406	0	65535	2 ^[1]		1	Config	UINT
2.9.1.5	Motor Cable Length	425	0.0	10000.0	100.0	m	0.01	Config	REAL
2.9.1.6	Maximum Motor Voltage	5433	-3.4e+38	3.4e+38	400.0 ^[1]	V	0.01	Config	REAL
2.9.1.7	Motor Voltage Limitation Mode	4620	0	1	0		1	Config	UINT

[1] Value depends on the power unit specification.

6.3.9.2 Induction Motor

Index	Name	Num	Min	Max	Default	Unit	Reso	Handling Type	Data Type
2.9.2.1	Stator Resistance Rs	408	0.0	1e+06	1.21	Ω	0.000001	Config	REAL
2.9.2.2	Rotor Resistance Rr	409	0.0	1e+06	0.79	Ω	0.000001	Config	REAL
2.9.2.3	Iron Loss Resistance Rfe	413	0.0	1e+10	874.0	Ω	0.000001	Config	REAL
2.9.2.4	Stator Leakage Reactance Xls	440	0.0	10.0	0.0040425	Ω	0.000001	Config	REAL
2.9.2.5	Rotor Leakage Reactance Xlr	441	0.0	10.0	0.0042335	Ω	0.000001	Config	REAL
2.9.2.6	Magnetizing Reactance Xm	442	0.0	10.0	0.14961	Ω	0.000001	Config	REAL
2.9.2.7	Magnetizing Reactance Saturation Point 1 Current	443	0.0	3.40e+38	0.0	A	0.01	Config	REAL
2.9.2.8	Magnetizing Reactance Saturation Point 2 Current	444	0.0	3.40e+38	0.0	A	0.01	Config	REAL
2.9.2.9	Magnetizing Reactance Saturation Point 3 Current	445	0.0	3.40e+38	0.0	A	0.01	Config	REAL
2.9.2.10	Magnetizing Reactance Saturation Point 4 Current	446	0.0	3.40e+38	0.0	A	0.01	Config	REAL
2.9.2.11	Magnetizing Reactance Saturation Point 5 Current	447	0.0	3.40e+38	0.0	A	0.01	Config	REAL
2.9.2.12	Magnetizing Reactance Saturation Point 1	448	0.0	3.40e+38	0.0	Ω	0.000001	Config	REAL
2.9.2.13	Magnetizing Reactance Saturation Point 2	449	0.0	3.40e+38	0.0	Ω	0.000001	Config	REAL
2.9.2.14	Magnetizing Reactance Saturation Point 3	450	0.0	3.40e+38	0.0	Ω	0.000001	Config	REAL
2.9.2.15	Magnetizing Reactance Saturation Point 4	451	0.0	3.40e+38	0.0	Ω	0.000001	Config	REAL
2.9.2.16	Magnetizing Reactance Saturation Point 5	452	0.0	3.40e+38	0.0	Ω	0.000001	Config	REAL

6.3.9.3 Permanent Magnet Motor

Index	Name	Num	Min	Max	Default	Unit	Reso	Handling Type	Data Type
2.9.3.1	Back EMF	415	0.0	10000.0	190.0	V	0.01	Config	REAL
2.9.3.2	Stator Resistance Rs	408	0.0	1e+06	1.21	Ω	0.000001	Config	REAL
2.9.3.3	d-axis Inductance Ld	417	0.0	1.0	0.023	mH	0.000001	Config	REAL
2.9.3.4	d-axis Inductance LdSat	418	0.0	1.0	0.023	mH	0.000001	Config	REAL
2.9.3.5	Ld Saturation Point	426	0.0	300.0	100.0	%	0.000001	Config	REAL
2.9.3.6	q-axis Inductance Lq	427	0.0	1.0	0.085	mH	0.000	Config	REAL

Index	Name	Num	Min	Max	Default	Unit	Reso	Handling Type	Data Type
							001		
2.9.3.7	q-axis Inductance LqSat	422	0.0	1.0	0.085	mH	0.000 001	Config	REAL
2.9.3.8	Lq Saturation Point	424	0.0	300.0	100.0	%	0.000 001	Config	REAL
2.9.3.9	PMM Back EMF Based Speed Limit	1822	0	1	1		1	Config	BOOL
2.9.3.10	Feedback Angle Offset	9017	0.0	360.0	0.0	°	0.01	Config	REAL

6.3.9.4 U/f Settings

Index	Name	Num	Min	Max	Default	Unit	Reso	Handling Type	Data Type
2.9.4.1	Voltage Point 0	2600	0.0	3.4e+38	8.0	V	0.01	Config	REAL
2.9.4.2	Voltage Point 1	2601	0.0	3.4e+38	80.0	V	0.01	Config	REAL
2.9.4.3	Voltage Point 2	2602	0.0	3.4e+38	160.0	V	0.01	Config	REAL
2.9.4.4	Voltage Point 3	2603	0.0	3.4e+38	240.0	V	0.01	Config	REAL
2.9.4.5	Voltage Point 4	2604	0.0	3.4e+38	320.0	V	0.01	Config	REAL
2.9.4.6	Voltage Point 5	2605	0.0	3.4e+38	400.0	V	0.01	Config	REAL
2.9.4.7	Frequency Point 0	2610	0.0	2000.0	0.0	Hz	0.01	Config	REAL
2.9.4.8	Frequency Point 1	2611	0.0	2000.0	10.0	Hz	0.01	Config	REAL
2.9.4.9	Frequency Point 2	2612	0.0	2000.0	20.0	Hz	0.01	Config	REAL
2.9.4.10	Frequency Point 3	2613	0.0	2000.0	30.0	Hz	0.01	Config	REAL
2.9.4.11	Frequency Point 4	2614	0.0	2000.0	40.0	Hz	0.01	Config	REAL
2.9.4.12	Frequency Point 5	2615	0.0	2000.0	50.0	Hz	0.01	Config	REAL

6.3.9.5 FVC+ Settings

Index	Name	Num	Min	Max	Default	Unit	Reso	Handling Type	Data Type
2.9.5.1	Continuous Rs Estimation	428	0	1	1		1	Config	BOOL
2.9.5.2	Current Controller Kp	8021	0.0	1e+05	100.0	%	0.01	Config	REAL
2.9.5.3	Current Controller Ti	8022	0.1	1e+05	100.0	%	0.01	Config	REAL
2.9.5.4	Current Controller Band Stop Frequency	8023	0.0	3.4e+38	0.0	Hz	0.01	Config	REAL
2.9.5.5	Low-speed Mode	2816	0	4	0		1	Config	UINT
2.9.5.6	I/f Control Current Reference	2817	0.0	500.0	100.0	%	0.01	Config	REAL
2.9.5.7	I/f Control Speed Threshold	2818	1.0	3.4e+38	10.0	Hz	0.01	Config	REAL
2.9.5.8	Low Speed Minimum Current	2837	0.0	100.0	50.0	%	0.01	Config	REAL
2.9.5.9	Minimum Current Speed Threshold	2838	1.0	3.4e+38	10.0	Hz	0.01	Config	REAL
2.9.5.10	Flux Control Feedback	2502	0	2	0		1	Config	UINT
2.9.5.11	Relative HF Injection Voltage Gain	2821	5.0	2000.0	100.0	%	0.01	Config	REAL

Index	Name	Num	Min	Max	Default	Unit	Reso	Handling Type	Data Type
2.9.5.12	Relative HF Inject Bandwidth	2826	1.0	1000.0	100.0	%	0.01	Config	REAL
2.9.5.13	HF Injection Angle Comp. Gain	2822	-35.0	35.0	0.0	°	0.01	Config	REAL
2.9.5.14	HF Injection Angle Comp. Offset	2824	-25.0	25.0	0.0	°	0.01	Config	REAL
2.9.5.15	HF Injection Frequency	2823	0.0	3.4e+38	0.0	Hz	0.01	Config	REAL
2.9.5.16	IdIq Reference Ratio	1219	-100.0	100.0	0.0	%	1	Config	REAL
2.9.5.17	Torque Estimation Bandwidth	4612	0.0	10000.0	100.0	%	1	Config	REAL

6.3.9.6 VVC+ & U/f Settings

Index	Name	Num	Min	Max	Default	Unit	Reso	Handling Type	Data Type
2.9.6.1	Slip Compensation	2804	0.0	1000.0	100.0	%	0.01	Config	REAL
2.9.6.2	Slip Compensation Tc	2805	0.0	100.0	0.05	ms	1	Config	REAL
2.9.6.3	High-speed Load Comp.	2803	0.0	1000.0	100.0	%	0.01	Config	REAL
2.9.6.4	Low-speed Load Comp.	2802	0.0	1000.0	100.0	%	0.01	Config	REAL
2.9.6.5	Res. Damp. Gain	2806	0.0	50000.0	100.0	%	0.01	Config	REAL
2.9.6.6	Res. Damp. High Pass Tc	2807	0.0	100.0	0.05	ms	1	Config	REAL
2.9.6.7	Res. Damp Low Pass Tc	2808	0.0	100.0	0.001	ms	1	Config	REAL
2.9.6.8	Load Compensation Tc	8017	0.001	1.0	0.015	s	0.01	Config	REAL
2.9.6.9	Res. Damp. High Pass Tc (SM)	2819	0.0	1.0	0.0	s	0.01	Config	REAL

6.3.9.7 Load Settings

6.3.9.7.1 Inertia

Index	Name	Num	Min	Max	Default	Unit	Reso	Handling Type	Data Type
2.9.7.1.1	Inertia Estimation Mode	668	0	2	0		1	Process	UINT
2.9.7.1.2	Inertia Estimation Timeout	669	120.0	1800.0	900.0	s	0.01	Config	REAL
2.9.7.1.3	System Inertia	667	0.0	10000.0	0.0	kgm ²	0.01	Config	REAL

6.3.9.7.2 Torque & AEO

Index	Name	Num	Min	Max	Default	Unit	Reso	Handling Type	Data Type
2.9.7.2.1	Torque Characteristic	2809	0	2	0		1	Config	UINT
2.9.7.2.2	AEO Minimum Speed	2810	0.0	2000.0	10.0	Hz	0.01	Config	REAL
2.9.7.2.3	AEO Minimum Magnetization	2811	0.0	100.0	40.0	%	0.01	Config	REAL
2.9.7.2.4	Variable Torque Zero Speed Magnetization	8020	40.0	90.0	66.0	%	0.01	Config	REAL

6.3.10 Speed Control

6.3.10.1 Speed Controller

6.3.10.1.1 Basic Settings

Index	Name	Num	Min	Max	Default	Unit	Reso	Handling Type	Data Type
2.10.1.1.1	Speed Controller Type	5005	0	2	1		1	Config	UINT
2.10.1.1.2	Speed Controller Kp FVC+	4020	0.0	1000.0	15.0	%/Hz	0.01	Config	REAL
2.10.1.1.3	Speed Controller Ti FVC+	4021	0.0	100.0	0.1	s	0.01	Config	REAL
2.10.1.1.4	Acceleration Feedforward Gain	4022	0.0	10000.0	0.0	%	0.01	Config	REAL
2.10.1.1.5	Speed Control Loop Type	4038	3	3	3		1	Config	UINT
2.10.1.1.6	Speed Feedback Filter Tc	4544	0.0	1.0	0.005	ms	1	Config	REAL

6.3.10.1.2 Advanced Settings

Index	Name	Num	Min	Max	Default	Unit	Reso	Handling Type	Data Type
2.10.1.2.1	Virtual Friction Gain	4549	0.0	10000.0	0.0		0.1	Config	REAL
2.10.1.2.2	Zero-speed Damping Gain	5434	0.0	1000.0	100.0	%	0.01	Config	REAL

6.3.10.2 Load Drooping

Index	Name	Num	Min	Max	Default	Unit	Reso	Handling Type	Data Type
2.10.2.1	Load Drooping Mode	670	0	2	0		1	Config	UINT
2.10.2.2	Load Drooping	671	0.0	1000.0	0.0	%	0.01	Config	REAL
2.10.2.3	Load Drooping LP Tc	672	0.0	1.0	0.005	ms	1	Config	REAL
2.10.2.4	Load Drooping HP Tc	673	0.0	100.0	1.0	ms	1	Config	REAL
2.10.2.5	Drooping Removal Mode	4581	0	2	0		1	Config	UINT
2.10.2.6	Drooping Removal Transition Speed	4582	0.001	1000.0	1.0	Hz	0.01	Config	REAL
2.10.2.7	Load Drooping Assist Mode	4570	0	2	0		1	Config	UINT
2.10.2.8	Load Drooping Assist Gain	4508	0.0	1.0	0.01	Hz/%	0.01	Config	REAL
2.10.2.9	Load Drooping Assist Filter Tc	4536	0.0	100.0	0.1	s	0.01	Config	REAL
2.10.2.10	Load Drooping Assist Removal Limit	4537	0.0	100.0	5.0	Hz	0.01	Config	REAL
2.10.2.11	Load Drooping Assist Output Limit	4579	0.0	100.0	2.0	Hz	0.01	Config	REAL
2.10.2.12	Master Motor Torque Failure Protection	4580	0	1	0		1	Config	BOOL
2.10.2.13	Load Drooping Assist Analog Input	4583	0	29999	0		1	Config	UINT
2.10.2.14	Load Drooping Assist AI Scale	4584	0.0	300.0	300.0	%	0.01	Config	REAL
2.10.2.15	Load Drooping Assist Force Off Input	4585	0	29999	0		1	Config	UINT

6.3.11 Drive Control

6.3.11.1 Modulation

Index	Name	Num	Min	Max	Default	Unit	Reso	Handling Type	Data Type
2.11.1.1	Switching Frequency	2920	500	20000	3000.0	kHz	0.01	Config	REAL
2.11.1.2	Switching Frequency Motor With Sine Filter	2984	500	20000	8000.0	kHz	0.01	Config	REAL
2.11.1.3	Max. Switching Frequency	2924	500.0	20000.0	16000.0	kHz	0.01	Config	REAL
2.11.1.4	Min. Switching Frequency	2925	500.0	20000.0	1000.0	kHz	0.01	Config	REAL
2.11.1.5	Modulator Options	5093	0x0	0xffff	0x0		1	Config	WORD
2.11.1.6	Overmodulation	5094	0	1	1		1	Config	BOOL
2.11.1.7	Modulator Type	5100	1	6	1		1	Config	UDINT
2.11.1.8	Minimum Pulse Number Mode	5122	0	2	0		1	Config	UINT
2.11.1.9	Minimum Pulse Number	5123	0	30	15		0.1	Config	REAL
2.11.1.10	Output Phase Sequence	431	0	65535	0		1	Config	UINT

6.3.11.2 Power Unit Settings

Index	Name	Num	Min	Max	Default	Unit	Reso	Handling Type	Data Type
2.11.2.1	Power Unit Enable Mask	2835	0x0	0xffff	0xffff		1	Config	WORD
2.11.2.2	Unit Voltage Class	2832	1	4	1		1	Config	UINT
2.11.2.3	Overload Mode	2833	0	3	2		1	Config	UINT
2.11.2.4	DC-link Voltage Measurement Corr. Gain	6535	-1.0	1.0	0.0	%	0.01	Config	REAL
2.11.2.5	DC-link Voltage Measurement Corr. Offset	6534	-5.0	5.0	0.0	V	0.01	Config	REAL
2.11.2.6	HF DC-link Filter Mode	2944	0	2	2		1	Config	UINT

6.3.11.3 Cooling Fan Control

Index	Name	Num	Min	Max	Default	Unit	Reso	Handling Type	Data Type
2.11.3.1	Main Fan Minimum Speed	2932	0.0	100.0	0.0	%	0.1	Config	REAL

6.3.11.4 Rectifier Settings

Index	Name	Num	Min	Max	Default	Unit	Reso	Handling Type	Data Type
2.11.4.1	Grid Type	2942	0	5	0		1	Config	UINT
2.11.4.2	RFI Filter Mode	2943	0	2	2		1	Config	UINT
2.11.4.3	Supply Mode	1328	0	1	0		1	Config	UINT

6.3.12 Protections and Responses

6.3.12.1 General Settings

Index	Name	Num	Min	Max	Default	Unit	Reso	Handling Type	Data Type
2.12.1.1	Retry after Fault	2927	0	1	1		1	Config	BOOL
2.12.1.2	Smart Derate Mode	2345	0	1	0		1	Config	UINT

6.3.12.2 Responses

Index	Name	Num	Min	Max	Default	Unit	Reso	Handling Type	Data Type
2.12.2.1	DC-link Voltage Ripple Response	2929	0	2	1		1	Config	UDINT
2.12.2.2	Inverter Thermal Overload Response	2341	1	2	1		1	Config	UINT
2.12.2.3	ETR Overtemperature Response	2825	0	10	0		1	Config	UINT
2.12.2.4	Motor Sync Loss	2922	0	3	3		1	Config	UINT
2.12.2.5	Missing Phase Startup Detection	6070	0	65535	0		1	Config	UINT
2.12.2.6	Missing Motor Phase Response	2348	0	65535	1		1	Config	UINT
2.12.2.7	Disconnected Motor Response	2349	0	65535	0		1	Config	UINT
2.12.2.8	Motor Feedback Failure Response	4600	3	10	10		1	Config	UINT
2.12.2.9	Bad Speed Feedback Response	4628	0	10	10		1	Config	UINT
2.12.2.10	Invalid Grid Frequency Response	2337	1	2	1		1	Config	UINT
2.12.2.11	Missing Grid Phase Response	2338	1	3	1		1	Config	UDINT
2.12.2.12	Grid Undervoltage Protection	2344	0	1	1		1	Config	BOOL
2.12.2.13	Grid Voltage Imbalance Response	9056	0	2	1		1	Config	UINT
2.12.2.14	Rectifier Thermal Overload Response	2340	1	2	1		1	Config	UINT

6.3.12.3 External Event

Index	Name	Num	Min	Max	Default	Unit	Reso	Handling Type	Data Type
2.12.3.1	External Event 1 Input	4557	0	29999	0		1	Config	UINT
2.12.3.2	Ext. Event 1 Inverse Input	4558	0	29999	1		1	Config	UINT
2.12.3.3	External Event 1 Response	4559	0	10	10		1	Config	UINT
2.12.3.4	External Event 2 Input	4560	0	29999	0		1	Config	UINT
2.12.3.5	Ext. Event 2 Inverse Input	4561	0	29999	1		1	Config	UINT
2.12.3.6	External Event 2 Response	4562	0	10	10		1	Config	UINT
2.12.3.7	External Event Active Output	5184	0	29999	0		1	Config	UINT

6.3.12.4 Cooling Monitor

Index	Name	Num	Min	Max	Default	Unit	Reso	Handling Type	Data Type
2.12.4.1	Cooling Monitor Input	2400	0	29999	1		1	Config	UINT
2.12.4.2	Cooling Monitor Fault Delay	2401	0.0	100.0	3.0	s	0.01	Config	REAL
2.12.4.3	Cooling Monitor Response	2402	0	3	2		1	Config	UINT

6.3.12.5 Measured Temp. Protection

6.3.12.5.1 Temp. 1 Protection

Index	Name	Num	Min	Max	Default	Unit	Reso	Handling Type	Data Type
2.12.5.1.1	Temp. 1 Input	5206	0	29999	0		1	Config	UINT
2.12.5.1.2	Temp. 1 Limit 1	5207	-300.0	300.0	120.0	°C	0.01	Config	REAL
2.12.5.1.3	Temp. 1 Limit 2	5208	-300.0	300.0	150.0	°C	0.01	Config	REAL
2.12.5.1.4	Temp. 1 Limit 2 Response	5209	3	10	10		1	Config	UINT

6.3.12.5.2 Temp. 2 Protection

Index	Name	Num	Min	Max	Default	Unit	Reso	Handling Type	Data Type
2.12.5.2.1	Temp. 2 Input	5210	0	29999	0		1	Config	UINT
2.12.5.2.2	Temp. 2 Limit 1	5211	-300.0	300.0	120.0	°C	0.01	Config	REAL
2.12.5.2.3	Temp. 2 Limit 2	5212	-300.0	300.0	150.0	°C	0.01	Config	REAL
2.12.5.2.4	Temp. 2 Limit 2 Response	5213	3	10	10		1	Config	UINT

6.3.12.5.3 Temp. 3 Protection

Index	Name	Num	Min	Max	Default	Unit	Reso	Handling Type	Data Type
2.12.5.3.1	Temp. 3 Input	5214	0	29999	0		1	Config	UINT
2.12.5.3.2	Temp. 3 Limit 1	5215	-300.0	300.0	120.0	°C	0.01	Config	REAL
2.12.5.3.3	Temp. 3 Limit 2	5216	-300.0	300.0	150.0	°C	0.01	Config	REAL
2.12.5.3.4	Temp. 3 Limit 2 Response	5217	3	10	10		1	Config	UINT

6.3.12.5.4 Temp. 4 Protection

Index	Name	Num	Min	Max	Default	Unit	Reso	Handling Type	Data Type
2.12.5.4.1	Temp. 4 Input	5218	0	29999	0		1	Config	UINT
2.12.5.4.2	Temp. 4 Limit 1	5219	-300.0	300.0	120.0	°C	0.01	Config	REAL
2.12.5.4.3	Temp. 4 Limit 2	5220	-300.0	300.0	150.0	°C	0.01	Config	REAL
2.12.5.4.4	Temp. 4 Limit 2 Response	5221	3	10	10		1	Config	UINT

6.3.12.5.5 Temp. 5 Protection

Index	Name	Num	Min	Max	Default	Unit	Reso	Handling Type	Data Type
2.12.5.5.1	Temp. 5 Input	5222	0	29999	0		1	Config	UINT
2.12.5.5.2	Temp. 5 Limit 1	5223	-300.0	300.0	120.0	°C	0.01	Config	REAL
2.12.5.5.3	Temp. 5 Limit 2	5224	-300.0	300.0	150.0	°C	0.01	Config	REAL
2.12.5.5.4	Temp. 5 Limit 2 Response	5225	3	10	10		1	Config	UINT

6.3.12.5.6 Temp. 6 Protection

Index	Name	Num	Min	Max	Default	Unit	Reso	Handling Type	Data Type
2.12.5.6.1	Temp. 6 Input	5226	0	29999	0		1	Config	UINT
2.12.5.6.2	Temp. 6 Limit 1	5227	-300.0	300.0	120.0	°C	0.01	Config	REAL
2.12.5.6.3	Temp. 6 Limit 2	5228	-300.0	300.0	150.0	°C	0.01	Config	REAL
2.12.5.6.4	Temp. 6 Limit 2 Response	5229	3	10	10		1	Config	UINT

6.3.12.5.7 Temp. 7 Protection

Index	Name	Num	Min	Max	Default	Unit	Reso	Handling Type	Data Type
2.12.5.7.1	Temp. 7 Input	5239	0	29999	0		1	Config	UINT
2.12.5.7.2	Temp. 7 Limit 1	5243	-300.0	300.0	120.0	°C	0.01	Config	REAL
2.12.5.7.3	Temp. 7 Limit 2	5269	-300.0	300.0	150.0	°C	0.01	Config	REAL
2.12.5.7.4	Temp. 7 Limit 2 Response	5235	3	10	10		1	Config	UINT

6.3.12.5.8 Temp. Protection 8

Index	Name	Num	Min	Max	Default	Unit	Reso	Handling Type	Data Type
2.12.5.8.1	Temp. 8 Input	5240	0	29999	0		1	Config	UINT
2.12.5.8.2	Temp. 8 Limit 1	5247	-300.0	300.0	120.0	°C	0.01	Config	REAL
2.12.5.8.3	Temp. 8 Limit 2	5270	-300.0	300.0	150.0	°C	0.01	Config	REAL
2.12.5.8.4	Temp. 8 Limit 2 Response	5236	3	10	10		1	Config	UINT

6.3.12.5.9 Temp. Protection 9

Index	Name	Num	Min	Max	Default	Unit	Reso	Handling Type	Data Type
2.12.5.9.1	Temp. 9 Input	5241	0	29999	0		1	Config	UINT
2.12.5.9.2	Temp. 9 Limit 1	5249	-300.0	300.0	120.0	°C	0.01	Config	REAL
2.12.5.9.3	Temp. 9 Limit 2	5271	-300.0	300.0	150.0	°C	0.01	Config	REAL
2.12.5.9.4	Temp. 9 Limit 2 Response	5237	3	10	10		1	Config	UINT

6.3.12.5.10 Temp. Protection 10

Index	Name	Num	Min	Max	Default	Unit	Reso	Handling Type	Data Type
2.12.5.10.1	Temp. 10 Input	5242	0	29999	0		1	Config	UINT
2.12.5.10.2	Temp. 10 Limit 1	5268	-300.0	300.0	120.0	°C	0.01	Config	REAL
2.12.5.10.3	Temp. 10 Limit 2	5272	-300.0	300.0	150.0	°C	0.01	Config	REAL
2.12.5.10.4	Temp. 10 Limit 2 Response	5238	3	10	10		1	Config	UINT

6.3.12.5.11 Common

Index	Name	Num	Min	Max	Default	Unit	Reso	Handling Type	Data Type
2.12.5.11.1	Meas. Valid Range	5230	-300.0	300.0	[200, -50]	°C	0.01	Config	REAL
2.12.5.11.2	Meas. Out of Range Response	5231	0	10	3		1	Config	UINT

6.3.12.6 Motor Speed Error

Index	Name	Num	Min	Max	Default	Unit	Reso	Handling Type	Data Type
2.12.6.1	Speed Error Response	5080	0	10	0		1	Config	UINT
2.12.6.2	Speed Error Limit	5081	0.0	100.0	5.0	%	0.01	Config	REAL
2.12.6.3	Speed Error Delay	5082	0.0	100.0	0.1	s	0.01	Config	REAL

6.3.12.7 Lost Load Detection

Index	Name	Num	Min	Max	Default	Unit	Reso	Handling Type	Data Type
2.12.7.1	Lost-load Response	9072	0	10	0		1	Config	UINT
2.12.7.2	Lost-load Detection Torque Level	9070	5.0	100.0	10.0	%	0.1	Config	REAL
2.12.7.3	Lost-load Detection Delay	9071	0.0	600.0	10.0	s	0.1	Config	REAL

6.3.12.8 Motor Stall Protection

Index	Name	Num	Min	Max	Default	Unit	Reso	Handling Type	Data Type
2.12.8.1	Stall Protection Response	5083	0	10	0		1	Config	UINT
2.12.8.2	Stall Current Limit	5084	0.0	200.0	100.0	%	0.01	Config	REAL
2.12.8.3	Stall Speed Limit	5091	0.0	100.0	25.0	Hz	0.01	Config	REAL
2.12.8.4	Stall Time	5092	0.0	120.0	15.0	s	0.1	Config	REAL

6.3.12.9 Motor Overload

Index	Name	Num	Min	Max	Default	Unit	Reso	Handling Type	Data Type
2.12.9.1	Overload Signal Selection	4565	0	3	0		1	Config	UINT
2.12.9.2	Max. Overload Limit	4566	0.0	300.0	150.0	%	0.01	Config	REAL
2.12.9.3	Min. Overload Limit	4567	0.0	300.0	105.0	%	0.01	Config	REAL
2.12.9.4	Max. Time at Max. Limit	4568	0.0	10.0	1.0	s	0.01	Config	REAL
2.12.9.5	Max. Time at Min. Limit	4569	0.0	10.0	5.0	s	0.01	Config	REAL
2.12.9.6	Overload Response	4586	0	10	10		1	Config	UINT

6.3.12.10 Inhibited Stop

Index	Name	Num	Min	Max	Default	Unit	Reso	Handling Type	Data Type
2.12.10.1	Inhibited Stop Regen. Torque Response	3025	0	3	0		1	Config	UINT
2.12.10.2	Inhibited Stop Torque Limit Preset	3024	0.0	300.0	300.0	%	0.01	Config	REAL
2.12.10.3	Inhibited Stop Limit Increase Delay	3022	0.0	100.0	5.0	s	0.01	Config	REAL
2.12.10.4	Inhibited Stop Brake Closing Delay	3023	0.0	100.0	5.0	s	0.01	Config	REAL
2.12.10.5	Inhibited Stop Overvoltage Response	3026	0	2	0		1	Config	UINT
2.12.10.6	Inhibited Stop Undervoltage Response	3027	0	2	0		1	Config	UINT
2.12.10.7	Inhibited Stop Coast Delay	3028	0.0	100	5.0	s	0.01	Config	REAL

6.3.12.11 Thermistor Monitoring

Index	Name	Num	Min	Max	Default	Unit	Reso	Handling Type	Data Type
2.12.11.1	Thermistor Monitoring Response	5232	0	10	10		1	Config	UINT
2.12.11.2	Thermistor Monitor 1 Input	1520	0	29999	0		1	Config	UINT
2.12.11.3	Thermistor Monitor 2 Input	1522	0	29999	0		1	Config	UINT
2.12.11.4	Thermistor Monitor 3 Input	1524	0	29999	0		1	Config	UINT

6.3.12.12 Live Zero

Index	Name	Num	Min	Max	Default	Unit	Reso	Handling Type	Data Type
2.12.12.1	Live Zero Active Output	5185	0	29999	0		1	Config	UINT
2.12.12.2	Live Zero Response	4555	0	10	3		1	Config	UINT
2.12.12.3	Live Zero I/O Control Dependency	4509	0	1	0		1	Config	BOOL

6.3.12.13 Fieldbus Protections

Index	Name	Num	Min	Max	Default	Unit	Reso	Handling Type	Data Type
2.12.13.1	Fieldbus Fault Response	1303	0	10	1		1	Config	UINT
2.12.13.2	Process Data Timeout Response	5291	0	10	1		1	Config	UINT
2.12.13.3	Process Data Timeout Delay	1340	50.0	3.4e+38	1000.0	s	0.01	Config	REAL
2.12.13.4	Fieldbus Watchdog Response	5244	0	10	0		1	Config	UINT
2.12.13.5	Fieldbus Watchdog Delay	5245	0.0	3000.0	5.0	s	0.01	Config	REAL
2.12.13.6	Fieldbus Watchdog Start Delay	5246	0.0	3000.0	30.0	s	0.01	Config	REAL
2.12.13.7	FB Monitoring Control Place Dependency	1338	0	1	1		1	Config	BOOL

6.3.12.14 HMI Connection Loss

Index	Name	Num	Min	Max	Default	Unit	Reso	Handling Type	Data Type
2.12.14.1	HMI Connection Loss	5420	0	10	0		1	Config	UINT

6.3.12.15 Limit Supervision

Index	Name	Num	Min	Max	Default	Unit	Reso	Handling Type	Data Type
2.12.15.1	Limit Supervision Signal Number 1	5251	0	65535	0		1	Config	UINT
2.12.15.2	Limit Supervision 1 Type	5252	0	2	0		1	Config	USINT
2.12.15.3	Limit Supervision 1 Threshold	5253	0.0	1e+06	0.0		0.01	Config	REAL
2.12.15.4	Limit Supervision 1 Hysteresis	5255	0.0	100.0	0.0	%	0.01	Config	REAL
2.12.15.5	Limit Supervision Response 1	5250	0	10	10		1	Config	UINT
2.12.15.6	Limit Supervision 1 Output	5254	0	29999	0		1	Config	UINT
2.12.15.7	Limit Supervision Signal Number 2	5257	0	65535	0		1	Config	UINT
2.12.15.8	Limit Supervision 2 Type	5258	0	2	0		1	Config	USINT
2.12.15.9	Limit Supervision 2 Threshold	5259	0.0	1e+06	0.0		0.01	Config	REAL
2.12.15.10	Limit Supervision 2 Hysteresis	5261	0.0	100.0	0.0	%	0.01	Config	REAL
2.12.15.11	Limit Supervision Response 2	5256	0	10	10		1	Config	UINT
2.12.15.12	Limit Supervision Output 2	5260	0	29999	0		1	Config	UINT
2.12.15.13	Limit Supervision Signal Number 3	5263	0	65535	0		1	Config	UINT
2.12.15.14	Limit Supervision 3 Type	5264	0	2	0		1	Config	USINT
2.12.15.15	Limit Supervision 3 Threshold	5265	0.0	1e+06	0.0		0.01	Config	REAL

Index	Name	Num	Min	Max	Default	Unit	Reso	Handling Type	Data Type
2.12.15.16	Limit Supervision 3 Hysteresis	5267	0.0	100.0	0.0	%	0.01	Config	REAL
2.12.15.17	Limit Supervision Response 3	5262	0	10	10		1	Config	UINT
2.12.15.18	Limit Supervision Output 3	5266	0	29999	0		1	Config	UINT

6.3.12.16 Overcurrent Protection

Index	Name	Num	Min	Max	Default	Unit	Reso	Handling Type	Data Type
2.12.16.1	Overcurrent Protection Limit	2368	0.0	3.4e+38	0.0	%	0.01	Config	REAL

6.3.13 Mechanical Brake Control

Index	Name	Num	Min	Max	Default	Unit	Reso	Handling Type	Data Type
2.13.1	Brake Output	3007	0	29999	0		1	Config	UINT
2.13.2	Brake Priming Torque	3012	0.0	200.0	100.0	%	0.01	Config	REAL
2.13.3	Brake Priming Direction	3001	0	2	0		1	Config	UINT
2.13.4	Brake Priming Time	3000	0.0	5.0	0.2	s	0.1	Config	REAL
2.13.5	Brake Priming Timeout	3006	2.0	10.0	5.0	s	0.1	Config	REAL
2.13.6	Brake Release Time	3003	0.1	30.0	0.5	s	0.1	Config	REAL
2.13.7	Brake Open Input	3010	0	29999	0		1	Config	UINT
2.13.8	Brake Hover Time	3013	0.0	60.0	0.0	s	0.1	Config	REAL
2.13.9	Brake Closing Speed	3002	0.0	25.0	5.0	Hz	0.01	Config	REAL
2.13.10	Brake Close Time	3004	0.1	30.0	0.5	s	0.1	Config	REAL
2.13.11	Brake Closed Input	3011	0	29999	0		1	Config	UINT
2.13.12	Brake Disengaging Time	3005	0.0	5.0	0.2	s	0.1	Config	REAL
2.13.13	Brake Release Bandwidth	3015	0.0	10000.0	100.0	%	0.01	Config	REAL
2.13.14	Brake Control Active Output	5187	0	29999	0		1	Config	UINT
2.13.15	Brake Close Immediately On Fault	3040	0	1	1		1	Config	BOOL
2.13.16	Brake Closing DC Link Protection	3019	0	1	0		1	Config	BOOL
2.13.17	Brake Closing DC-Link Limit	3014	0.0	300.0	112.0	%	0.01	Config	REAL
2.13.18	Brake Closing DC-Link Delay	3018	0.0	1000.0	70.0	ms	0.01	Config	REAL
2.13.19	Brake Feedback Error Response	3042	3	10	3		1	Config	UINT
2.13.20	Brake Feedback Error Time	3043	0.0	30.0	1.0	s	0.1	Config	REAL
2.13.21	Brake Slip Detection Response	3031	0	1	0		1	Config	UINT
2.13.22	Brake Slip Limit	3030	0	3600.0	60	°	0.01	Config	REAL

6.3.14 Motor Breaker Control

Index	Name	Num	Min	Max	Default	Unit	Reso	Handling Type	Data Type
2.14.1	Breaker Manual Close Input	4705	0	29999	0		1	Config	UINT
2.14.2	Breaker Manual Open Input	4706	0	29999	0		1	Config	UINT
2.14.3	Breaker Close Feedback Input	4707	0	29999	0		1	Config	UINT
2.14.4	Breaker Open Feedback Input	4708	0	29999	0		1	Config	UINT
2.14.5	Breaker Close Output	4709	0	29999	0		1	Config	UINT
2.14.6	Breaker Open Output	4710	0	29999	0		1	Config	UINT
2.14.7	Breaker Control Enable Input	4735	0	29999	0		1	Config	UINT
2.14.8	Automatic/Manual Breaker Control	4701	0	1	0		1	Config	UINT
2.14.9	Breaker Command Signal Mode	4702	0	2	1		1	Config	UINT
2.14.10	Breaker Feedback Signal Mode	4703	0	2	1		1	Config	UINT
2.14.11	Breaker Opening Condition	4704	0	3	2		1	Config	UINT
2.14.12	Breaker Monitor Delay	4711	0.0	120.0	1.0	s	0.01	Config	REAL
2.14.13	Breaker Monitor Response	4712	0	10	10		1	Config	UINT
2.14.14	Breaker Control Disable Mode	4736	0	1	0		1	Config	UINT

6.3.15 Output Filter

Index	Name	Num	Min	Max	Default	Unit	Reso	Handling Type	Data Type
2.15.1	Output Filter Type	5501	0	1	0		1	Config	UINT
2.15.2	Filter Capacitance	5502	0.0	1.0	0.0	μF	0.01	Config	REAL
2.15.3	Filter Inductance	5503	0.0	1.0	0.0	mH	0.000 001	Config	REAL

6.3.16 Inching

Index	Name	Num	Min	Max	Default	Unit	Reso	Handling Type	Data Type
2.16.1	Inching Mode	1081	0	2	0		1	Config	UINT
2.16.2	Enable Inching Input	1080	0	29999	1		1	Config	UINT
2.16.3	Inching Ramp Time	1083	0.01	3600.0	10.0	s	0.01	Config	REAL
2.16.4	Inching Reference 1	1082	-1000.0	1000.0	15.0	Hz	0.01	Config	REAL
2.16.5	Inching Activate Input 1	1084	0	29999	0		1	Config	UINT
2.16.6	Inching Reference 2	1085	-1000.0	1000.0	-15.0	Hz	0.01	Config	REAL
2.16.7	Inching Activate Input 2	1086	0	29999	0		1	Config	UINT
2.16.8	Inching Active Output	1087	0	29999	0		1	Config	UINT

6.3.17 Advanced Harmonic Filter

Index	Name	Num	Min	Max	Default	Unit	Reso	Handling Type	Data Type
2.17.1	Advanced Harmonic Filter	3410	0	1	0		1	Config	BOOL
2.17.2	Capacitor Disconnect Output	3412	0	29999	0		1	Config	UINT
2.17.3	Thermal Switch Response	3413	1	2	1		1	Config	UINT
2.17.4	Thermal Switch Input	3414	0	29999	0		1	Config	UINT

6.3.18 Master Follower

Index	Name	Num	Min	Max	Default	Unit	Reso	Handling Type	Data Type
2.18.1	Master Follower Mode Input	5752	0	29999	0		1	Config	UINT
2.18.2	Master Follower Mode 1	5536	0	3	0		1	Config	INT
2.18.3	Master Follower Mode 2	5750	0	3	0		1	Config	INT
2.18.4	Number of Drives	5537	1	16	1		1	Config	INT
2.18.5	Drive Number	5751	1	16	1		1	Config	INT
2.18.6	Follower Start Mode	5753	0	1	1		1	Config	BOOL
2.18.7	Follower Stop Mode	5754	0	2	0		1	Config	UINT
2.18.8	Follower Speed Reference Source	5755	0	4	2		1	Config	UINT
2.18.9	Follower Torque Reference Source	5756	0	1	1		1	Config	UINT
2.18.10	Master Follower Watchdog Response	5542	0	10	10		1	Config	INT
2.18.11	Master Follower Watchdog Delay	5757	0	3000	3	s	0.01	Config	REAL
2.18.12	Master Follower Watchdog Start Delay	5758	0	3000	30	s	0.01	Config	REAL

6.3.19 Logic Settings

Index	Name	Num	Min	Max	Default	Unit	Reso	Handling Type	Data Type
2.19.1	Logic User Parameter 1	380	-30000000	30000000	0		0.0001	Config	REAL
2.19.2	Logic User Parameter 2	381	-30000000	30000000	0		0.0001	Config	REAL
2.19.3	Logic User Parameter 3	382	-30000000	30000000	0		0.0001	Config	REAL
2.19.4	Logic User Parameter 4	383	-30000000	30000000	0		0.0001	Config	REAL
2.19.5	Logic User Parameter 5	384	-30000000	30000000	0		0.0001	Config	REAL
2.19.6	Logic User Parameter 6	385	-30000000	30000000	0		0.0001	Config	REAL
2.19.7	Logic User Parameter 7	386	-30000000	30000000	0		0.0001	Config	REAL
2.19.8	Logic User Parameter 8	387	-30000000	30000000	0		0.0001	Config	REAL
2.19.9	Logic Process Input 1	360	-30000000	30000000	0		0.0001	Process	REAL
2.19.10	Logic Process Input 2	361	-30000000	30000000	0		0.0001	Process	REAL
2.19.11	Logic Process Input 3	362	-30000000	30000000	0		0.0001	Process	REAL
2.19.12	Logic Process Input 4	363	-30000000	30000000	0		0.0001	Process	REAL
2.19.13	Logic Process Output 1	370	-30000000	30000000	0		0.0001	Process	REAL
2.19.14	Logic Process Output 2	371	-30000000	30000000	0		0.0001	Process	REAL
2.19.15	Logic Process Output 3	372	-30000000	30000000	0		0.0001	Process	REAL
2.19.16	Logic Process Output 4	373	-30000000	30000000	0		0.0001	Process	REAL

6.4 Maintenance & Service

6.4.1 Software Information

Index	Name	Num	Min	Max	Default	Unit	Reso	Handling Type	Data Type
3.1.1	Application Version	151					1	Process	STRING

6.4.1.1 Manifest

This is the manifest screen showing detailed software information in the control panel. With MyDrive® Insight, the same information is available on the “Device Info” screen. Check the available information via the control panel or MyDrive® Insight.

6.4.2 Events

6.4.2.1 Active Events

This is the active events screen shown only in the control panel. With MyDrive® Insight, the same information is available on the “Events” screen. Check the available information via the control panel or MyDrive® Insight.

6.4.2.2 Event History

This is the event history screen shown only in the control panel. With MyDrive® Insight, the same information is available on the “Events” screen. Check the available information via the control panel or MyDrive® Insight.

6.4.2.3 Event Simulation

Index	Name	Num	Min	Max	Default	Unit	Reso	Handling Type	Data Type
3.2.3.1	Event Simulation	1401	0	10	0		1	Config	UINT
3.2.3.2	Event Sim. Number	1402	0	65535	5260		1	Config	UINT

6.4.2.4 Event Auto Reset

Index	Name	Num	Min	Max	Default	Unit	Reso	Handling Type	Data Type
3.2.4.1	Auto Reset	1405	0	1	0		1	Config	BOOL
3.2.4.2	Auto Reset Max Attempts	1406	0	20	3		1	Config	UINT
3.2.4.3	Auto Reset Time Interval	1407	1.0	600.0	10.0	s	1	Config	REAL

6.4.3 Operational Counters

Index	Name	Num	Min	Max	Default	Unit	Reso	Handling Type	Data Type
3.3.1	Control Unit On Time	2000	0	4.29e+9	0	h	1	Process	UDINT
3.3.2	Power Unit On Time	2001	0	4.29e+9	0	h	1	Process	UDINT
3.3.3	Energy Consumption	2002	-	-	-	kWh	1	Process	ULINT
3.3.4	Ground Faults	2004	0	50000	0		1	Process	UINT
3.3.5	Overvoltage Faults	2005	0	50000	0		1	Process	UINT
3.3.6	Overcurrent Faults	2006	0	50000	0		1	Process	UINT
3.3.7	Short Circuit Faults	2007	0	50000	0		1	Process	UINT
3.3.8	Number Of Starts	2008	0	4.29e+9	0		1	Process	UDINT
3.3.9	Active Running Hours	2009	0	4.29e+9	0	h	1	Process	UDINT
3.3.10	Motor Operation Below 10 Hz	2010	0	4.29e+9	0	h	1	Process	UDINT
3.3.11	Flash 0 Wear Counter	2100	0	4.29e+9	0		1	Config	UDINT
3.3.12	Flash 1 Wear Counter	2101	0	4.29e+9	0		1	Config	UDINT

6.4.4 I/O Testing

Index	Name	Num	Min	Max	Default	Unit	Reso	Handling Type	Data Type
3.4.1	Test Digital Input	3220	0	29999	0		1	Config	UINT
3.4.2	Digital Input Test State	3224	0	1	0		1	Process	BOOL
3.4.3	Test Digital Output	3223	0	29999	0		1	Config	UINT
3.4.4	Digital Output Test State	3234	0	1	0		1	Config	BOOL
3.4.5	Test Analog Input	3222	0	29999	0		1	Config	UINT
3.4.6	Analog Input Test Value	3228	0.0	100.0	0.0	%	0.01	Process	REAL
3.4.7	Test Analog Output	3225	0	29999	0		1	Config	UINT
3.4.8	Analog Output Test Value	3226	0.0	100.0	0.0	%	0.01	Config	REAL
3.4.9	Temperature Test Input	3221	0	29999	0		1	Config	UINT

Index	Name	Num	Min	Max	Default	Unit	Reso	Handling Type	Data Type
3.4.10	Temperature Input Test Value	3227	-300.0	300.0	0.0	°C	0.01	Process	REAL

6.4.5 Backup & Restore

6.4.5.1 Backup

This is a menu screen for creating parameter backups from the control panel. With MyDrive® Insight, similar options are available via the “Backup” button within the “Parameters” screen. Check the available settings via the control panel or MyDrive® Insight.

6.4.5.2 Restore

This is a menu screen for restoring parameter backups from the control panel. With MyDrive® Insight, similar options are available via the “Restore” button within the “Parameters” screen. Check the available settings via the control panel or MyDrive® Insight.

6.4.6 Expert Tools

6.4.6.1 Cybersecurity

Index	Name	Num	Min	Max	Default	Unit	Reso	Handling Type	Data Type
3.6.1.1	Max. Login Attempts	5900	3	255	10		1	Config	USINT
3.6.1.2	Max. Login Cooldown Time	5901	1	1440	5	min	1	Config	UDINT
3.6.1.3	Security Event Log IP	5902					1	Config	STRING
3.6.1.4	Security Event Log Port	5903	0	65535	6514		1	Config	UINT
3.6.1.5	System Use Notification	5908					1	Config	STRING

6.4.6.2 Troubleshooting

Index	Name	Num	Min	Max	Default	Unit	Reso	Handling Type	Data Type
3.6.2.1	Force Recommissioning	5904	0	1	0		1	Config	BOOL
3.6.2.2	Save Diagnostic Log	5905	0	1	0		1	Config	BOOL
3.6.2.3	Service Access	5906	0	1	0		1	Config	USINT

6.5 Functional Safety

6.5.1 Basic Settings

Index	Name	Num	Min	Max	Default	Unit	Reso	Handling Type	Data Type
4.1.1	Startup Acknowledge Input	9922	0	29999	0		1	Config	UINT
4.1.2	I/O Failure Acknowledge Input	9921	0	29999	0		1	Config	UINT

6.5.2 STO

Index	Name	Num	Min	Max	Default	Unit	Reso	Handling Type	Data Type
4.2.1	Safe Torque Off Response	9910	14	15	14		1	Config	UINT
4.2.2	Safe Torque Off Output	9911	0	29999	0		1	Config	UINT
4.2.3	Safe Torque Off Acknowledge Input	9920	0	29999	0		1	Config	UINT

6.5.3 SS1

Index	Name	Num	Min	Max	Default	Unit	Reso	Handling Type	Data Type
4.3.1	Safe Stop 1 Response	9901	0	1	0		1	Config	UINT
4.3.2	Safe Deceleration Ramp	9900	0	1000	0		0.01	Config	REAL

6.6 Device Settings

6.6.1 Time & Units

Index	Name	Num	Min	Max	Default	Unit	Reso	Handling Type	Data Type
5.1.1	Date and Time	2800	-	-	-		1	Config	DATE_ AND_ TIME
5.1.2	Unit Selection	2801	0	255	0		1	Config	USINT
5.1.3	Speed Unit	2813	0	255	0		1	Config	USINT
5.1.4	Torque Unit	2827	0	255	0		1	Config	USINT
5.1.5	Power Unit	2815	0	255	0		1	Config	USINT
5.1.6	Temperature Unit	2814	0	255	0		1	Config	USINT
5.1.7	Length Unit	2829	0	255	0		1	Config	USINT
5.1.8	Inertia Unit	2828	0	255	0		1	Config	USINT
5.1.9	Time Mode	6232	0	1	0		1	Config	UINT
5.1.10	NTP Server 1	6233	0.0.0.0	255.255.255.255	-		1	Config	STRING
5.1.11	NTP Server 2	6234	0.0.0.0	255.255.255.255	-		1	Config	STRING

6.6.2 Control Panel

6.6.2.1 Readout Screen 1

Index	Name	Num	Min	Max	Default	Unit	Reso	Handling Type	Data Type
5.2.1.1	Readout Field 1.1	300	0	4.29e+9	9011		1	Config	UDINT
5.2.1.2	Readout Field 1.2	301	0	4.29e+9	0		1	Config	UDINT
5.2.1.3	Readout Field 1.3	302	0	4.29e+9	0		1	Config	UDINT
5.2.1.4	Readout Field 1.4	303	0	4.29e+9	0		1	Config	UDINT
5.2.1.5	Readout Field 1.5	304	0	4.29e+9	0		1	Config	UDINT

6.6.2.2 Readout Screen 2

Index	Name	Num	Min	Max	Default	Unit	Reso	Handling Type	Data Type
5.2.2.1	Readout Field 2.1	310	0	4.29e+9	9010		1	Config	UDINT
5.2.2.2	Readout Field 2.2	311	0	4.29e+9	9009		1	Config	UDINT
5.2.2.3	Readout Field 2.3	312	0	4.29e+9	9008		1	Config	UDINT
5.2.2.4	Readout Field 2.4	313	0	4.29e+9	0		1	Config	UDINT
5.2.2.5	Readout Field 2.5	314	0	4.29e+9	0		1	Config	UDINT

6.6.3 Custom Status Word

Index	Name	Num	Min	Max	Default	Unit	Reso	Handling Type	Data Type
5.3.1	Custom Status Word B0	2411	0	515	0		1	Config	UINT
5.3.2	Custom Status Word B1	2412	0	515	0		1	Config	UINT
5.3.3	Custom Status Word B2	2413	0	515	0		1	Config	UINT
5.3.4	Custom Status Word B3	2414	0	515	0		1	Config	UINT
5.3.5	Custom Status Word B4	2415	0	515	0		1	Config	UINT
5.3.6	Custom Status Word B5	2416	0	515	0		1	Config	UINT
5.3.7	Custom Status Word B6	2417	0	515	0		1	Config	UINT
5.3.8	Custom Status Word B7	2418	0	515	0		1	Config	UINT
5.3.9	Custom Status Word B8	2419	0	515	0		1	Config	UINT
5.3.10	Custom Status Word B9	2420	0	515	0		1	Config	UINT
5.3.11	Custom Status Word B10	2421	0	515	0		1	Config	UINT
5.3.12	Custom Status Word B11	2422	0	515	0		1	Config	UINT
5.3.13	Custom Status Word B12	2423	0	515	0		1	Config	UINT
5.3.14	Custom Status Word B13	2424	0	515	0		1	Config	UINT
5.3.15	Custom Status Word B14	2425	0	515	0		1	Config	UINT
5.3.16	Custom Status Word B15	2426	0	515	0		1	Config	UINT

6.7 Option Board Settings

6.7.1 I/O And Relay

This group and its subgroups appear only if an I/O And Relay OC7C1 option is included in the drive. This menu appears as many times as there are these options in the system. Each menu and its parameters have the suffix of their option slot.

6.7.1.1 I/O And Relay Status

Index	Name	Num	Min	Max	Default	Unit	Reso	Handling Type	Data Type
9.3.1	Digital Input Bit Word	1614	0x0	0xffff	0x0		1	Process	WORD
9.3.2	Digital Output Bit Word	1615	0x0	0xffff	0x0		1	Process	WORD
9.3.3	T31 Analog Output Value	1613	-20.0	20.0	0.0		0.01	Process	REAL

Index	Name	Num	Min	Max	Default	Unit	Reso	Handling Type	Data Type
9.3.4	T33 Analog Input Value	1611	-20.0	20.0	0.0		0.01	Process	REAL
9.3.5	T34 Analog Input Value	1612	-20.0	20.0	0.0		0.01	Process	REAL

6.7.1.2 Digital Inputs/Outputs

6.7.1.2.1 Input T13

Index	Name	Num	Min	Max	Default	Unit	Reso	Handling Type	Data Type
9.4.1.1	T13 Terminal Mode	2015	0	3	0		1	Config	UINT
9.4.1.2	T13 Signal Inversion	2291	0	1	0		1	Config	UINT
9.4.1.3	T13 Standard Debounce Filtering Time	2024	0.0	0.1	0.0	ms	1	Config	REAL

6.7.1.2.2 Input T14

Index	Name	Num	Min	Max	Default	Unit	Reso	Handling Type	Data Type
9.4.2.1	T14 Terminal Mode	2016	0	3	0		1	Config	UINT
9.4.2.2	T14 Signal Inversion	2292	0	1	0		1	Config	UINT
9.4.2.3	T14 Standard Debounce Filtering Time	2029	0.0	0.1	0.0	ms	1	Config	REAL

6.7.1.2.3 Input T15

Index	Name	Num	Min	Max	Default	Unit	Reso	Handling Type	Data Type
9.4.3.1	T15 Terminal Mode	2022	0	3	0		1	Config	UINT
9.4.3.2	T15 Signal Inversion	2295	0	1	0		1	Config	UINT
9.4.3.3	T15 Standard Debounce Filtering Time	2297	0.0	0.1	0.0	ms	1	Config	REAL

6.7.1.2.4 Input T16

Index	Name	Num	Min	Max	Default	Unit	Reso	Handling Type	Data Type
9.4.4.1	T16 Terminal Mode	2298	0	3	0		1	Config	UINT
9.4.4.2	T16 Signal Inversion	2296	0	1	0		1	Config	UINT
9.4.4.3	T16 Standard Debounce Filtering Time	2260	0.0	0.1	0.0	ms	1	Config	REAL

6.7.1.2.5 Input T17

Index	Name	Num	Min	Max	Default	Unit	Reso	Handling Type	Data Type
9.4.5.1	T17 Terminal Mode	2017	0	3	0		1	Config	UINT
9.4.5.2	T17 Signal Inversion	2293	0	1	0		1	Config	UINT
9.4.5.3	T17 Standard Debounce	2034	0.0	0.1	0.0	ms	1	Config	REAL

Index	Name	Num	Min	Max	Default	Unit	Reso	Handling Type	Data Type
	Filtering Time								

6.7.1.2.6 Input T18

Index	Name	Num	Min	Max	Default	Unit	Reso	Handling Type	Data Type
9.4.6.1	T18 Terminal Mode	2018	0	3	0		1	Config	UINT
9.4.6.2	T18 Signal Inversion	2294	0	1	0		1	Config	UINT
9.4.6.3	T18 Standard Debounce Filtering Time	2039	0.0	0.1	0.0	ms	1	Config	REAL

6.7.1.2.7 Output T21

Index	Name	Num	Min	Max	Default	Unit	Reso	Handling Type	Data Type
9.4.1.1	T13 Terminal Mode	2015	0	3	0		1	Config	UINT
9.4.1.2	T13 Signal Inversion	2291	0	1	0		1	Config	UINT
9.4.1.3	T13 Standard Debounce Filtering Time	2024	0.0	0.1	0.0	ms	1	Config	REAL

6.7.1.2.8 Output T22

Index	Name	Num	Min	Max	Default	Unit	Reso	Handling Type	Data Type
9.4.8.1	T22 Terminal Mode	4016	0	1	0		1	Config	UINT
9.4.8.2	T22 Digital Output Type	4014	0	3	3		1	Config	UINT

6.7.1.3 Analog Inputs/Outputs

6.7.1.3.1 Output T31

Index	Name	Num	Min	Max	Default	Unit	Reso	Handling Type	Data Type
9.5.1.1	T31 Terminal Mode	2019	0	5	0		1	Config	UINT
9.5.1.2	T31 Terminal Type	2284	0	2	1		1	Config	UINT
9.5.1.3	T31 Minimum Value	2283	-20.0	20.0	0.0		0.01	Config	REAL
9.5.1.4	T31 Maximum Value	2282	-20.0	20.0	10.0		0.01	Config	REAL

6.7.1.3.2 Input T33

Index	Name	Num	Min	Max	Default	Unit	Reso	Handling Type	Data Type
9.5.2.1	T33 Terminal Mode	2020	0	6	0		1	Config	UINT
9.5.2.2	T33 Terminal Type	2273	1	2	1		0.01	Config	UINT
9.5.2.3	T33 Minimum Value	2272	-20.0	20.0	0.0		0.01	Config	REAL
9.5.2.4	T33 Maximum Value	2271	-20.0	20.0	10.0		0.01	Config	REAL
9.5.2.5	T33 Filter Time	2270	0.0	60.0	0.0	ms	1	Config	REAL

Index	Name	Num	Min	Max	Default	Unit	Reso	Handling Type	Data Type
9.5.2.6	T33 Live Zero Threshold Value	2274	-20.0	20.0	-10.0		0.01	Config	REAL
9.5.2.7	T33 Live Zero Timeout Value	2275	0.0	60.0	0.0	s	0.01	Config	REAL

6.7.1.3.3 Input T34

Index	Name	Num	Min	Max	Default	Unit	Reso	Handling Type	Data Type
9.5.3.1	T34 Terminal Mode	2021	0	6	0		1	Config	UINT
9.5.3.2	T34 Terminal Type	2279	1	2	1		0.01	Config	UINT
9.5.3.3	T34 Minimum Value	2278	-20.0	20.0	0.0		0.01	Config	REAL
9.5.3.4	T34 Maximum Value	2277	-20.0	20.0	10.0		0.01	Config	REAL
9.5.3.5	T34 Filter Time	2276	0.0	60.0	0.0	ms	1	Config	REAL
9.5.3.6	T34 Live Zero Threshold Value	2280	-20.0	20.0	-10.0		0.01	Config	REAL
9.5.3.7	T34 Live Zero Timeout Value	2281	0.0	60.0	0.0	s	0.01	Config	REAL

6.7.2 Encoder/Resolver

This group and its subgroups appear only if an Encoder/Resolver OC7M0 option is included in the drive. This menu appears as many times as there are these options in the system. Each menu and its parameters have the suffix of their option slot.

6.7.2.1 Encoder/Resolver Status

Index	Name	Num	Min	Max	Default	Unit	Reso	Handling Type	Data Type
9.3.1	Digital Input Bit Word	1614	0x0	0xffff	0x0		1	Process	WORD
9.3.2	Digital Output Bit Word	1615	0x0	0xffff	0x0		1	Process	WORD
9.3.3	T31 Analog Output Value	1613	-20.0	20.0	0.0		0.01	Process	REAL
9.3.4	T33 Analog Input Value	1611	-20.0	20.0	0.0		0.01	Process	REAL
9.3.5	T34 Analog Input Value	1612	-20.0	20.0	0.0		0.01	Process	REAL

6.7.2.2 Configuration

Index	Name	Num	Min	Max	Default	Unit	Reso	Handling Type	Data Type
9.4.1	Interface Configuration	4000	0	3010	0		1	Config	UINT
9.4.2	Encoder Supply Voltage	4002	3	24	5	V	1	Config	UINT
9.4.3	Supply Sense	4035	0	1	0		1	Config	BOOL
9.4.4	Invert Direction Channel 1	4092	0	1	0		1	Config	BOOL
9.4.5	Invert Direction Channel 2	4093	0	1	0		1	Config	BOOL

6.7.2.3 Incremental Settings

Index	Name	Num	Min	Max	Default	Unit	Reso	Handling Type	Data Type
9.5.1	Resolution Channel 1	4008	0	65535	1024		1	Config	UINT
9.5.2	Resolution Channel 2	4009	0	65535	1024		1	Config	UINT

6.7.2.4 Absolute Settings

Index	Name	Num	Min	Max	Default	Unit	Reso	Handling Type	Data Type
9.6.1	Singleturn Resolution	4010	1	32	13		1	Config	UINT
9.6.2	Multiturn Resolution	4011	0	32	12		1	Config	UINT
9.6.3	EnDat Clock Rate	4036	0	65535	13		1	Config	UINT
9.6.4	SSI Data Format	4034	0	1	1		1	Config	BOOL
9.6.5	BiSS/SSI Clock Rate	4037	0	65535	18		1	Config	UINT
9.6.6	HIPERFACE Baud Rate	4094	0	65535	4		1	Config	UINT
9.6.7	HIPERFACE Parity	4095	0	65535	2		1	Config	UINT

6.7.2.5 Resolver Settings

Index	Name	Num	Min	Max	Default	Unit	Reso	Handling Type	Data Type
9.7.1	Excitation Voltage	4005	2	8	5	V	1	Config	UINT
9.7.2	Excitation Frequency	4004	2000	20000	5000	Hz	1	Config	UINT
9.7.3	Number of Pole Pairs	4003	1	255	1		1	Config	UINT
9.7.4	Transformation Ratio	4096	0.0	2.0	0.1		0.01	Config	REAL

6.7.3 Temperature Measurement

This group and its subgroups appear only if a Temperature Measurement OC7T0 option is included in the drive. This menu appears as many times as there are these options in the system. Each menu and its parameters have the suffix of their option slot.

6.7.3.1 Temperature Measurement Status

Index	Name	Num	Min	Max	Default	Unit	Reso	Handling Type	Data Type
9.3.2	T4 Temperature Value	4040	-1000.0	1000.0	0.0	°C	1	Process	REAL
9.3.3	T8 Temperature Value	4041	-1000.0	1000.0	0.0	°C	1	Process	REAL
9.3.4	T12 Temperature Value	4042	-1000.0	1000.0	0.0	°C	1	Process	REAL
9.3.5	T16 Temperature Value	4043	-1000.0	1000.0	0.0	°C	1	Process	REAL
9.3.6	T20 Temperature Value	4044	-1000.0	1000.0	0.0	°C	1	Process	REAL

6.7.3.2 Temperature Inputs

6.7.3.2.1 Input T4

Index	Name	Num	Min	Max	Default	Unit	Reso	Handling Type	Data Type
9.4.1.1	T4 Terminal Mode	4045	0	7	0		1	Config	UINT
9.4.1.2	T4 Connection Type	4046	0	4	0		1	Config	UINT
9.4.1.3	T4 Temperature Sensor Type	4047	0	19	0		1	Config	UINT
9.4.1.4	T4 Offset	4048	-50.0	50.0	0.0	°C	1	Config	REAL

6.7.3.2.2 Input T8

Index	Name	Num	Min	Max	Default	Unit	Reso	Handling Type	Data Type
9.4.2.1	T8 Terminal Mode	4049	0	7	0		1	Config	UINT
9.4.2.2	T8 Connection Type	4050	0	4	0		1	Config	UINT
9.4.2.3	T8 Temperature Sensor Type	4051	0	19	0		1	Config	UINT
9.4.2.4	T8 Offset	4052	-50.0	50.0	0.0	°C	1	Config	REAL

6.7.3.2.3 Input T12

Index	Name	Num	Min	Max	Default	Unit	Reso	Handling Type	Data Type
9.4.3.1	T12 Terminal Mode	4053	0	7	0		1	Config	UINT
9.4.3.2	T12 Connection Type	4054	0	4	0		1	Config	UINT
9.4.3.3	T12 Temperature Sensor Type	4055	0	19	0		1	Config	UINT
9.4.3.4	T12 Offset	4056	-50.0	50.0	0.0	°C	1	Config	REAL

6.7.3.2.4 Input T16

Index	Name	Num	Min	Max	Default	Unit	Reso	Handling Type	Data Type
9.4.4.1	T16 Terminal Mode	2298	0	7	0		1	Config	UINT
9.4.4.2	T16 Connection Type	4058	0	4	0		1	Config	UINT
9.4.4.3	T16 Temperature Sensor Type	4059	0	19	0		1	Config	UINT
9.4.4.4	T16 Offset	4060	-50.0	50.0	0.0	°C	1	Config	REAL

6.7.3.2.5 Input T20

Index	Name	Num	Min	Max	Default	Unit	Reso	Handling Type	Data Type
9.4.5.1	T20 Terminal Mode	4017	0	7	0		1	Config	UINT
9.4.5.2	T20 Connection Type	4062	0	4	0		1	Config	UINT
9.4.5.3	T20 Temperature Sensor Type	4063	0	19	0		1	Config	UINT
9.4.5.4	T20 Offset	4064	-50.0	50.0	0.0	°C	1	Config	REAL

6.8 Connectivity

6.8.1 Integrated Communication

6.8.1.1 Communication interfaces

6.8.1.1.1 Host Settings

Index	Name	Num	Min	Max	Default	Unit	Reso	Handling Type	Data Type
10.1.1.1.1	Fully Qualified Domain Name	7036	-	-	-		1	Config	STRING

6.8.1.1.2 Ethernet Interface X0

6.8.1.1.2.1 IPv4 Settings

This is a menu screen for enabling IP configuration of the X0 interface. Check the available settings via the control panel or MyDrive® Insight.

Note: To ensure that outgoing IP packets are routed correctly, configure the IP address of the X1/X2 interfaces to a different subnet than the IP address of the X0 interface.

6.8.1.1.2.2 IPv4 Status

This is a menu screen containing information about the IP configuration of the X0 interface. Check the available information via the control panel or MyDrive® Insight.

6.8.1.1.3 Ethernet Interface X1/X2 Settings

6.8.1.1.3.1 IPv4 Settings

This is a menu screen for enabling IP configuration of the X1/X2 interface. Check the available settings via the control panel or MyDrive® Insight.

Note: To ensure that outgoing IP packets are routed correctly, configure the IP address of the X1/X2 interfaces to a different subnet than the IP address of the X0 interface.

6.8.1.1.3.2 IPv4 Status

This is a menu screen containing information about the IP configuration of the X1/X2 interface. Check the available information via the control panel or MyDrive® Insight.

6.8.1.1.4 Ethernet port X0

6.8.1.1.4.1 X0 Settings

Index	Name	Num	Min	Max	Default	Unit	Reso	Handling Type	Data Type
10.1.1.4.1.1	Link configuration X0	7047	0	4	0		1	Config	USINT

6.8.1.1.5 Ethernet port X1

6.8.1.1.5.1 X1 Settings

Index	Name	Num	Min	Max	Default	Unit	Reso	Handling Type	Data Type
10.1.1.5.1.1	Link Configuration X1	7048	0	4	0		1	Config	USINT

6.8.1.1.6 Ethernet port X2

6.8.1.1.6.1 X2 Settings

Index	Name	Num	Min	Max	Default	Unit	Reso	Handling Type	Data Type
10.1.1.6.1.1	Link Configuration X2	7049	0	4	0		1	Config	USINT

6.8.1.1.7 Port Mirroring

This is a menu screen for enabling and disabling the port-mirroring function for network troubleshooting with a network analyzer tool. Check the available configurations via the control panel or MyDrive® Insight.

6.8.1.2 Protocols

6.8.1.2.1 PROFINET®

6.8.1.2.1.1 Status

6.8.1.2.1.1.1 PROFINET® Report

This is the PROFINET® report screen showing active PROFINET® connection and configuration information. Check the available information via the control panel or MyDrive® Insight.

6.8.1.2.1.2 Configuration

Index	Name	Num	Min	Max	Default	Unit	Reso	Handling Type	Data Type
10.1.2.1.2.1	Name of Station	7080	-	-	-		1	Config	STRING

6.8.1.2.1.3 Diagnosis

Index	Name	Num	Min	Max	Default	Unit	Reso	Handling Type	Data Type
10.1.2.1.3.1	Diagnostic Fault	7081	0	1	1		1	Config	BOOL
10.1.2.1.3.2	Diagnostic Warning	7083	0	1	1		1	Config	BOOL

6.8.1.2.2 Modbus® TCP

6.8.1.2.2.1 Configuration

Index	Name	Num	Min	Max	Default	Unit	Reso	Handling Type	Data Type
10.1.2.2.1.1	Persistent Storage	7061	0	1	0		1	Config	BOOL
10.1.2.2.1.2	Byte Order	7062	0	1	0		1	Config	USINT

Index	Name	Num	Min	Max	Default	Unit	Reso	Handling Type	Data Type
10.1.2.2.1.3	Word Order	7063	0	1	1		1	Config	USINT

6.8.1.2.3 EtherNet/IP

6.8.1.2.3.1 Status

6.8.1.2.3.1.1 EtherNet/IP Report

This is the EtherNet/IP report screen showing active EtherNet/IP connection and configuration information. Check the available information via the control panel or MyDrive® Insight.

6.8.1.2.4 EtherCAT®

6.8.1.2.4.1 Status

6.8.1.2.4.1.1 EtherCAT Report

This is the EtherCAT report screen showing active EtherCAT connection and configuration information. Check the available information via the control panel or MyDrive® Insight.

6.8.1.2.4.2 Configuration

Index	Name	Num	Min	Max	Default	Unit	Reso	Handling Type	Data Type
10.1.2.4.2.1	Device ID	7084	0	65535	0		1	Config	UINT

6.8.1.2.5 General Settings

Index	Name	Num	Min	Max	Default	Unit	Reso	Handling Type	Data Type
10.1.2.5.1	SNMP Agent	5907	0	1	1		1	Config	BOOL

6.8.2 RS485 Communication OC7F3

This group and its subgroups appear only if an RS485 Communication OC7F3 option is included in the drive. This menu appears as many times as there are these option boards in the system. Each menu and its parameters have the suffix of their option slot.

6.8.2.1 RS485 Settings

This is a menu screen for enabling RS485 Communication settings. The configurable parameters are port address, baud rate, data frame settings and line termination. These settings can be configured via the control panel or MyDrive® Insight.

6.8.2.2 Modbus Settings

Index	Name	Num	Min	Max	Default	Unit	Reso	Handling Type	Data Type
-	Persistent Storage	7061	0	1	0		1	Config	BOOL
-	Byte Order	7062	0	1	0		1	Config	USINT
-	Word Order	7063	0	1	1		1	Config	USINT

7 Parameter Descriptions

7.1 How to Read Parameter Descriptions

The following chapters contain descriptions of all the parameters in the Propulsion and Machinery application software. Each chapter represents a single subgroup within the menu structure.

First the group is described. After that all parameters are listed and described. If applicable, the parameter selections are listed in a table, containing further descriptions for each selection.

The following is an example of a parameter description:

P1.2.3^[1] Parameter Name^[2] No. 1234^[3]
This is a parameter description.^[4]

Number	Name	Description
0 ^[5]	Name of selection 1 ^[6]	Description of selection 1. ^[7]
1	Name of selection 2	Description of selection 2.

[1]: The index number of the parameter, that is, the menu location.

[2]: Name of the parameter.

[3]: Unique identification number of the parameter.

[4]: Description of the parameter.

[5]: Selection number.

[6]: Selection name.

[7]: Description of the selection.

7.2 Monitoring

This group contains readouts for monitoring the operation of the drive.

7.2.1 Basic Monitoring

This group contains readouts for monitoring the basic operation of the drive.

P1.1.1 Motor Current No. 9000

Shows the actual motor current.

P1.1.2 Motor Voltage No. 9005

Shows the actual motor voltage.

P1.1.3 Motor Torque No. 9009

Shows the actual motor torque.

P1.1.4 Motor Shaft Power No. 9008

Shows the actual power at the motor shaft.

P1.1.5 Motor Shaft Speed No. 9010

Shows the shaft speed in RPM.

P1.1.6 Motor Power Factor No. 4618

Shows the actual motor power factor.

P1.1.7 Output Frequency **No. 9015**

Shows the output frequency.

P1.1.8 DC-link Voltage **No. 9044**

Shows the actual DC-link voltage.

P1.1.9 DC-link Power **No. 5117**

Shows the actual DC-link power.

P1.1.10 Application Status Word 1 **No. 6201**

Shows the application status word 1. The meaning of the bits is described in the following table.

Bit No.	Name	Description
0	Motor control ready	Motor control indicates that the drive is ready to run (Bit 0 of Motor Control Status Word).
1	Motor running	Motor control indicates that the motor is running (Bit 1 of Motor Control Status Word).
2	Info active (static)	Static status signal for info events. True = One or more info level events are active, False = No info level events active.
3	Warning active (static)	Static status signal for warning events. True = One or more warning level events are active, False = No warning level events active.
4	Fault active (static)	Static status signal for fault events. True = One or more fault level events are active, False = No fault level events active.
5	PC control active	PC (MyDrive® Insight) is the active control place commanding the drive.
6	Panel control active	Control panel is the active control place commanding the drive.
7	I/O control active	I/O is the active control place commanding the drive.
8	FB control active	Fieldbus is the active control place commanding the drive.
9	Advanced control active	Advanced control is the active control place commanding the drive.
10	Reserved	-
11	Run enabled	The Run Enable Input is active allowing the drive to start or maintain running.
12	Start command active	The start request is active from the active control place.
13	Quick stop active	The quick stop is activated from I/O or fieldbus.
14	Panel force stop active	The stop request is activated with the control panel Stop button, when the drive is not commanded from the panel. Requires that Allow Local Control Force Stop is enabled.
15	Reserved	-

P1.1.11 Application Status Word 2 **No. 6202**

Shows the application status word 2. The meaning of the bits is described in the following table.

Bit No.	Name	Description
0	Info active (toggled)	Toggled status signal for info events. This signal toggles down for 1 second, whenever a new info event is activated while another info event is already active.
1	Warning active (toggled)	Toggled status signal for warning events. This signal toggles down for 1 second, whenever a new warning is activated while another warning is already active.

Application Guide

Bit No.	Name	Description
2	Fault active (toggled)	Toggled status signal for fault events. This signal toggles down for 1 second, whenever a new fault is activated while another fault is already active.
3	Speed feedback in use	Bit for distinguishing between open and closed-loop control. True = Motor speed is provided by an actual feedback device (encoder or resolver), False = Motor speed is a calculated value.
4	Reserved	-
5	Reversing based on reference	Bit for indicating a reversing operation from the speed reference. True = Speed reference is less than zero, False = Speed reference is higher than zero.
6	Reversing based on motor speed	Bit for indicating a reversing operation from the actual motor speed. True = Motor speed is less than zero, False = Motor speed is higher than zero.
7	Mechanical brake open feedback active	Status signal for mechanical brake open state feedback (Bit 2 of Mechanical Brake Status Word). True = Open status active, False = Open status deactivated.
8	Mechanical brake closed feedback active	Status signal for mechanical brake closed state feedback (Bit 3 of Mechanical Brake Status Word). True = Closed status active, False = Closed status deactivated.
9	Mechanical brake close command active	Status signal for mechanical brake close command from the mechanical brake controller (Inverse of Bit 15 of Mechanical Brake Status Word). True = Close command active, False = Close command not active.
10	Interlocks active	At least one of the drive interlock signals is active (Start Interlock 1, Start Interlock 2, Run Interlock 1, Run Interlock 2, or Motor Breaker Interlock).
11	Speed control active	Speed control is the active control mode.
12	Torque control active	Torque control is the active control mode.
13	Power control active	Power control is the active control mode.
14	Reserved	-
15	Reserved	-

P1.1.12 Fault Status Word 1 No. 6203

Shows the fault status word 1. The meaning of the bits is described in the following table. Each bit is active if the associated fault events are active.

Bit No.	Name	Description
0	Over current	Rectifier overcurrent, DC-link capacitor overcurrent, output overcurrent, or output short circuit has occurred. Event list: events in group number 0x2340
1	DC-Link Over voltage	DC-link voltage is above normal operating range. Event list: events in group number 0x3211 and 0x3212
2	DC-Link Under voltage	DC-link voltage is below normal operating range. Event list: events in group number 0x3221
3	Unit over temperature	IGBT, rectifier heat sink, or power unit temperature is above normal operating range. Event list: events in group number 0x4310
4	Unit under temperature	IGBT, rectifier heat sink, or power unit temperature is below normal operating range. Event list: events in group number 0x4320
5	Control card over temp	Control Board System on Chip temperature is below normal operating range. Event list: events in group number 0x43FE
6	Input phase	Missing or unbalanced rectifier voltage. Event list: events in group number 0x3130
7	Output phase	One or more output (motor) currents are missing. Event list: events in group number 0x23FF
8	Earth	High-impedance ground leakage current on motor side. Event list: events in group number 0x2110 and 0x2330
9	Fan failure	Failure occurred in one or more fans installed in the system. Event list: events in group number 0x70FF
10	Fieldbus issue	Fieldbus process data timeout, watchdog, loss of fieldbus I/O or connection has occurred. Event list: events in group number 0x8100
11	HMI control lost	While in control of the drive, control panel or PC tool connection is lost. Event list: events in group number 0x7580
12	Feedback failure	Encoder/Resolver option is indicating a fault, or its speed value is unreliable. Event list: events in group number 0x72FF
13	Thermistor	One or more thermistor protection functions are active. Event list: events in group number 0x4281
14	Auxiliary device	One or more AuxBus connected power component temperatures are above normal operating range. Event list: events in group number 0x42FF
15	External temperature measurement	One or more temperature measurement protection functions are active. Event list: events in group number 0x4280
16	Grid side overvoltage	Excessive voltage spikes or voltage above normal operating range in the rectifier input. Event list: events in group number 0x3110
17	Grid side undervoltage	Rectifier input voltage is below normal operating range. Event list: events in group number 0x3120

P1.1.13 Fault Status Word 2 No. 6204

Shows the current state of the Fault Status Word 2. The meaning of the bits is described in the following table. Each bit is active if the associated fault events are active.

Bit No.	Name	Description
0	Live Zero	One or more analog input terminal voltages are below the live zero threshold. Event list: events in group number 0x7502
1	Motor Overload	One or more overload supervisions are active. Event list: events in group number 0x2311
2	Limit Supervision	One or more limit supervision functions are active. Event list: event in group number 0x8080
3	Quick stop	A quick stop command has been given via I/O or fieldbus input. Event list: event number 5130
4	Motor over temperature	The Electronic Thermal Relay function is active based on motor current and speed. Event list: event number 4177
5	Speed error	Measured or estimated motor speed differs from the given speed reference. Event list: event number 5131
6	External event	An external event command has been given. Event list: events in group number 0xFF01
7	Cooling monitor	An external cooling device is reporting an error. Event list: events in group number 0x4380
8	Mechanical Brake	Mechanical brake feedback is faulty or the closing or opening of the brake has failed. Event list: events in group number 0x7080
9	Safe Torque Off	The safe torque off function is active. Event list: events in group number 0x54FE
10	Stall Protection	Motor stall protection is active based on high motor current while speed was low. Event list: event number 5146
11	Interlocking	A start has been requested while a start interlock was active, or a run interlock became active while the drive was running. Event list: event number 5140
12	Brake Chopper	A brake chopper related event is active. Event list: events in group number 0x7110, 0x7111 and 0x7113

P1.1.14 Warning Status Word 1 No. 6205

Shows the warning status word 1. The meaning of the bits is described in the following table. Each bit is active if the associated warning events are active.

Bit No.	Name	Description
0	Over current	Rectifier overcurrent, DC-link capacitor overcurrent, output overcurrent, or output short circuit has occurred. Event list: events in group number 0x2340
1	DC-Link Over voltage	DC-link voltage is above normal operating range. Event list: events in group number 0x3211 and 0x3212
2	DC-Link Under voltage	DC-link voltage is below normal operating range. Event list: events in group number 0x3221
3	Unit over temperature	IGBT, rectifier heat sink, or power unit temperature is above normal operating range. Event list: events in group number 0x4310
4	Unit under temperature	IGBT, rectifier heat sink, or power unit temperature is below normal operating range. Event list: events in group number 0x4320
5	Control card over temp	Control board System on Chip temperature is below normal operating range.

Bit No.	Name	Description
		Event list: events in group number 0x43FE
6	Input phase	Missing or unbalanced rectifier voltage. Event list: events in group number 0x3130
7	Output phase	One or more output (motor) currents are missing. Event list: events in group number 0x23FF
8	Earth	High-impedance ground leakage current on motor side. Event list: events in group number 0x2110 and 0x2330
9	Fan failure	Failure occurred in one or more fans installed in the system. Event list: events in group number 0x70FF
10	Fieldbus issue	Fieldbus process data timeout, watchdog, loss of fieldbus I/O or connection has occurred. Event list: events in group number 0x8100
11	HMI control lost	While in control of the drive, Control Panel or PC tool connection has been lost. Event list: events in group number 0x7580
12	Feedback failure	Encoder/Resolver option is indicating a fault, or its speed value is unreliable. Event list: events in group number 0x72FF
13	Thermistor	One or more thermistor protection functions are active. Event list: events in group number 0x4281
14	Auxiliary device	One or more AuxBus connected power component temperatures are above normal operating range. Event list: events in group number 0x42FF
15	External temperature measurement	One or more temperature measurement protection functions are active. Event list: events in group number 0x4280
16	Grid side overvoltage	Excessive voltage spikes or voltage above normal operating range in the rectifier input. Event list: events in group number 0x3110
17	Grid side undervoltage	Rectifier input voltage is below normal operating range. Event list: events in group number 0x3120

P1.1.15 Warning Status Word 2 No. 6206

Shows the current state of the Warning Status Word 2. The meaning of the bits is described in the following table. Each bit is active if the associated warning events are active.

Bit No.	Name	Description
0	Live Zero	One or more analog input terminal voltages are below the live zero threshold. Event list: events in group number 0x7502
1	Motor Overload	Motor current, torque, or power has exceeded the overload monitoring function thresholds. Event list: events in group number 0x2380
2	Limit Supervision	One or more limit supervision functions are active. Event list: events in group number 0x8080
3	Quick stop	A quick stop command has been given via I/O or fieldbus input. Event list: event number 5130
4	Motor over temperature	The Electronic Thermal Relay function is active based on motor current and speed. Event list: event number 4177
5	Speed error	Measured or estimated motor speed differs from the given speed reference. Event list: event number 5131
6	External event	An external event command has been given. Event list: events in group number 0xFF01

Bit No.	Name	Description
7	Cooling monitor	An external cooling device is reporting an error. Event list: events in group number 0x4380
8	Mechanical Brake	Mechanical brake feedback is faulty or the closing or opening of the brake has failed. Event list: events in group number 0x7080
9	Safe Torque Off	The safe torque off function is active. Event list: events in group number 0x54FE
10	Stall Protection	Motor stall protection is active based on high motor current while speed was low. Event list: event number 5146
11	Interlocking	A start has been requested while a start interlock was active, or a run interlock became active while the drive was running. Event list: event number 5140
12	Brake chopper	A brake chopper related event is active. Event list: events in group number 0x7110, 0x7111 and 0x7113

P1.1.16 Start Ready Status Word **No. 6207**

Shows the Start Ready Status Word. All conditions (bits) must be true before the drive is ready to start. The meaning of the bits is described in the following table.

Bit No.	Name	Description
0	Motor control ready	Motor control indicates that the drive is ready to run (Bit 0 of Motor Control Status Word).
1	Start interlock 1	Start interlock 1 is not preventing the start.
2	Start interlock 2	Start interlock 2 is not preventing the start.
3	Run interlock 1	Run interlock 1 is not preventing the start.
4	Run interlock 2	Run interlock 2 is not preventing the start.
5	Motor breaker interlock	Motor breaker interlock is not preventing the start.
6	No Quick stop	Quick stop is not preventing the start.
7	No Ramp stop	Ramp stop is not preventing the start.
8	No Coast stop	Coast stop is not preventing the start.
9	No Joystick sleep mode.	Joystick sleep mode is not active.
10...15	Reserved	

P1.1.17 Last Fault Number **No. 1610**

Shows the number of the most recent active fault.

P1.1.18 Last Warning Number **No. 1609**

Shows the number of the most recent active warning.

7.2.2 Control Mode and Reference Monitoring

P1.2.1 Active Control Mode **No. 3460**

Shows the active control mode. The indication numbers are presented in the following table.

Number	Name	Description
0	Speed Control Mode	The drive is in speed control.

Number	Name	Description
1	Torque Control Mode	The drive is in torque control.
2	Power Control Mode	The drive is in power control.

P1.2.2 Speed Reference **No. 1718**

Shows the speed reference before ramping, and after limiting done in the Speed Limits group.

P1.2.3 Torque Reference **No. 1821**

Shows the torque reference before ramping in % of motor nominal torque.

P1.2.4 Power Reference **No. 1820**

Shows the power reference before ramping in % of motor nominal power.

7.2.3 Limit Monitoring

P1.3.1 Relative Output Current Limit **No. 2700**

Shows the maximum current in % of the nominal grid current.

P1.3.2 Torque Limit Motoring **No. 1812**

Shows the torque limit in motoring mode in % of nominal motor torque.

P1.3.3 Torque Limit Regenerative **No. 1813**

Shows the regenerative torque limit in % of nominal motor torque.

P1.3.4 Power Limit Motor **No. 1814**

Shows the motor power limit in % of motor nominal power.

P1.3.5 Power Limit Regenerative **No. 1815**

Shows the regenerative power limit in % of motor nominal power.

P1.3.6 Overvoltage Control Limit **No. 6544**

Shows the DC-link overvoltage controller limit.

P1.3.7 Undervoltage Control Limit **No. 6546**

Shows the DC-link undervoltage controller limit.

P1.3.8 Brake Power **No. 2933**

Shows the power dissipated in the brake resistor.

P1.3.9 Average Brake Power **No. 2934**

Shows the average power dissipated in the brake resistor, calculated over 120 s.

7.2.4 Control Place Monitoring

P1.4.1 Active Control Place **No. 113**

Shows the control place that controls the drive. The indication numbers are presented in the following table.

Number	Name	Description
0	PC control	PC (MyDrive® Insight) is the active control place commanding the drive.
1	Local control	Local (control panel) is the active control place commanding the drive.
2	Fieldbus control	Fieldbus is the active control place commanding the drive.
3	I/O control	I/O is the active control place commanding the drive.
4	Advanced control	Advanced control is the active control place commanding the drive.

P1.4.2 FB Forcing Requested **No. 116**

Shows the status of the fieldbus control place forcing request.

Number	Name	Description
0	Inactive	FB forcing is not requested.
1	Active	FB forcing is requested.

P1.4.3 I/O Forcing Requested **No. 117**

Shows the status of the I/O-control place forcing request.

Number	Name	Description
0	Inactive	I/O forcing is not requested.
1	Active	I/O forcing is requested.

P1.4.4 Advanced Forcing Requested **No. 118**

Shows the status of the advanced control place forcing request.

Number	Name	Description
0	Inactive	Advanced control place forcing is not requested.
1	Active	Advanced control place forcing is requested.

P1.4.5 Local Control Forcing Requested **No. 124**

Shows the status of the local control place forcing request (made from control panel REM/LOC button).

Number	Name	Description
0	Inactive	Local (panel) control forcing is not requested.
1	Active	Local (panel) control forcing is requested.

7.2.5 Speed Control Monitoring

P1.5.1 Motor Shaft Speed **No. 9010**

Shows the shaft speed in RPM.

P1.5.2 Motor Electrical Speed **No. 9011**

Shows the motor shaft speed in electrical domain.

P1.5.3 Output Frequency **No. 9015**

Shows the output frequency.

P1.5.4 Feedback Speed **No. 9007**

Shows the feedback speed.

P1.5.5 Feedback Electrical Angle **No. 9016**

Shows the feedback device angle in the electrical domain. Its value is needed for manually tuning the feedback angle offset.

P1.5.6 Speed Error **No. 4023**

Shows the difference between speed reference after ramp and motor speed.

P1.5.7 Speed Reference **No. 1718**

Shows the speed reference before ramping, and after limiting is done in the Speed Limits group.

P1.5.8 Speed Reference Before Ramp **No. 6049**

Shows the value of speed reference before the ramp generator, and after filtering with Speed Ref. Filter Tc.

P1.5.9 Speed Reference After Ramp **No. 6150**

Shows the value of the speed reference after the ramp generator.

P1.5.10 Final Speed Reference **No. 6151**

Shows the value of the speed reference before feeding it to the speed controller. Includes effect of load drooping.

P1.5.11 Feedback Electrical Speed **No. 9012**

Shows the feedback speed in electrical domain.

P1.5.12 Load Drooping Speed **No. 674**

Shows the load drooping speed.

7.2.6 Torque Control Monitoring**P1.6.1 Motor Torque** **No. 9009**

Shows the actual motor torque.

P1.6.2 Relative Motor Torque **No. 1708**

Shows the motor torque in % of the nominal motor torque.

P1.6.3 Torque Limit Motoring **No. 1812**

Shows the torque limit in motoring mode in % of nominal motor torque.

P1.6.4 Torque Limit Regenerative **No. 1813**

Shows the regenerative torque limit in % of nominal motor torque.

P1.6.5 Torque Reference **No. 1821**

Shows the torque reference before ramping in % of motor nominal torque.

P1.6.6 Torque Ref. Ramp Out **No. 6152**

Shows the torque reference after ramping in % of motor nominal torque.

P1.6.7 Torque Reference Final **No. 6154**

Shows the value of the final torque reference given to the motor controller in % of nominal motor torque.

7.2.7 Power Control Monitoring

P1.7.1 Relative Motor Shaft Power **No. 1707**

Shows the actual motor shaft power in % of the nominal motor shaft power.

P1.7.2 Power Reference **No. 1820**

Shows the power reference before ramping in % of motor nominal power.

P1.7.3 Power Ref. Ramp Out **No. 4076**

Shows the power reference after ramping in % of motor nominal power.

P1.7.4 Power Limit Motor **No. 1814**

Shows the motor power limit in % of motor nominal power.

P1.7.5 Power Limit Regenerative **No. 1815**

Shows the regenerative power limit in % of motor nominal power.

7.2.8 Motor Control Monitoring

7.2.8.1 Motor Status

P1.8.1.1 Motor Current **No. 9000**

Shows the actual motor current.

P1.8.1.2 Relative Motor Current **No. 9001**

Shows the actual motor current in % of the nominal motor current.

P1.8.1.3 U-phase RMS Current **No. 9020**

Shows the U-phase RMS current.

P1.8.1.4 V-phase RMS Current **No. 9021**

Shows the V-phase RMS current.

P1.8.1.5 W-phase RMS Current **No. 9022**

Shows the W-phase RMS current.

P1.8.1.6 Motor Voltage **No. 9005**

Shows the actual motor voltage.

P1.8.1.7 U-V RMS voltage **No. 9023**

Shows the line-to-line RMS voltage between U and V.

P1.8.1.8 V-W RMS voltage **No. 9024**

Shows the line-to-line RMS voltage between V and W.

P1.8.1.9 W-U RMS voltage No. 9025

Shows the line-to-line RMS voltage between W and U.

P1.8.1.10 Motor Torque No. 9009

Shows the actual motor torque.

P1.8.1.11 Relative Motor Torque No. 1708

Shows the motor torque in % of the nominal motor torque.

P1.8.1.12 Motor Shaft Power No. 9008

Shows the actual power at the motor shaft.

P1.8.1.13 Relative Motor Shaft Power No. 1707

Shows the actual motor shaft power in % of the nominal motor shaft power.

P1.8.1.14 Motor Electrical Power No. 9043

Shows the actual motor power.

P1.8.1.15 Motor Thermal Load (ETR) No. 2951

Shows the estimated thermal load of the motor calculated by the ETR function.

P1.8.1.16 AMA Progress No. 429

Shows the progress of the Automatic Motor Adaptation (AMA).

7.2.8.2 Motor Control Status**P1.8.2.1 Motor Control Status Word No. 1714**

Shows the motor control status word. The meaning of the bits is described in the following table.

Bit No.	Name	Description
0	Ready	Indicates that drive is ready to run.
1	Run	Indicates that motor is running.
2	Reverse	Indicates that motor running in reverse direction, that is, motor speed is below 0.
3	Fault	Indicates that an event is preventing the drive from modulating.
4	Reference Chain Released	Indicates that drive has magnetized the motor after start request and the reference is taken from the reference chain.
5	At reference	Indicates that the motor is running at given speed reference.
6	Zero speed	Indicates that the motor is running at zero speed (in standstill).
7	Protection Mode Active	Indicates that the drive has entered safe modulation mode after recovering from a hardware fault through fast re-enable.
8..15	Reserved	-

P1.8.2.2 Motor Control Ready Status Word No. 1716

Shows the motor control ready status word. All status bits must be true before the drive is ready. The meaning of the bits is described in the following table.

Bit No.	Name	Description
0	Run enabled	The Run Enable Input is active allowing the drive to start or maintain running.

Bit No.	Name	Description
1	No faults	Indicates that no faults are active.
2	DC-link precharge done	The DC-link precharge is completed.
3	Dc voltage in limits	The DC-link voltage is not below undervoltage trip or above overvoltage control level.
4	Power manager init	Power units are ready to start.
5	No brake test running	Brake resistor test is not running.
6	Reserved	-
7	Grid voltage in limits	Grid voltage is within allowed operating range.
8	Temperature in limits	Drive's internal temperature measurements are within allowed operating range.
9	Valid motor data	Motor data is set correctly. Motor data needs to be nonzero, given in motor side operation point and within reasonable range of drive nominal rating.
10	Valid control config	Indication that control configuration is valid. Possible reasons for invalid configuration: - Torque control is supported only in FVC+ principle. - U/f control is not supported for permanent magnet motors. - Closed loop speed control is not supported in U/f control. - Constant control frequency is not supported with minimum pulse number switching frequency. - Overvoltage control limit must be higher than undervoltage control limit. - Speed feedback option data must be correct in closed loop control.
11...15	Reserved	-

1.8.2.3 Motor Regulator Status Word No. 1715

Shows the motor regulator status word. The meaning of the bits is described in the following table.

Bit No.	Name	Description
0	Current limit (mot)	Motoring side current limit is hit.
1	Current limit (regen)	Regenerating side current limit is hit.
2	Torque limit (mot)	Motoring side torque limit is hit.
3	Torque limit (regen)	Regenerating side torque limit is hit.
4	Overvoltage limit	Overvoltage limit is hit.
5	Undervoltage limit	Undervoltage limit is hit.
6	Power limit (mot)	Motoring side power limit is hit.
7	Power limit (regen)	Regenerating side power limit is hit.
8	Speed limit	Motor speed limit is hit.
9	AC-brake	AC-brake is active.
10...15	Reserved	-

7.2.8.3 Load Status

1.8.3.1 Inertia Estimation Status No. 666

Shows the status of the inertia estimation routine. The indication numbers are presented in following table.

Number	Name	Description
0	Inactive	Inertia estimation is inactive.

Number	Name	Description
1	In progress	Inertia estimation is ongoing.
2	Completed successfully	Inertia estimation has been performed successfully.
3	Completed unsuccessfully	Inertia estimation has been performed unsuccessfully.

7.2.9 Drive Control Monitoring

P1.9.1 Actual Switching Frequency **No. 2923**

Shows the actual switching frequency.

P1.9.2 Modulation Index **No. 5101**

Shows the modulation index.

P1.9.3 Control Unit Temperature **No. 2952**

Shows the temperature of the control unit.

7.2.10 Protection Monitoring

7.2.10.1 Measured Temp. Protection Status

P1.10.1.1 Protection 1 Temp. **No. 5200**

Shows the temperature measured for the temperature protection.

P1.10.1.2 Protection 2 Temp. **No. 5201**

Shows the temperature measured for the temperature protection.

P1.10.1.3 Protection 3 Temp. **No. 5202**

Shows the temperature measured for the temperature protection.

P1.10.1.4 Protection 4 Temp. **No. 5203**

Shows the temperature measured for the temperature protection.

P1.10.1.5 Protection 5 Temp. **No. 5204**

Shows the temperature measured for the temperature protection.

P1.10.1.6 Protection 6 Temp. **No. 5205**

Shows the temperature measured for the temperature protection.

P1.10.1.7 Protection 7 Temp. **No. 5273**

Shows the temperature measured for the temperature protection.

P1.10.1.8 Protection 8 Temp. **No. 5274**

Shows the temperature measured for the temperature protection.

P1.10.1.9 Protection 9 Temp. **No. 5275**

Shows the temperature measured for the temperature protection.

P1.10.1.10 Protection 10 Temp. **No. 5276**

Shows the temperature measured for the temperature protection.

7.2.11 Mechanical Brake Control Monitoring

P1.11.1 Mechanical Brake Status Word **No. 3016**

Shows the mechanical brake status word. The meaning of the bits is described in the following table.

Bit No.	Name	Description
0	Enabled	Indicates that mechanical brake controller has been enabled with parameter Brake Output. This signal will be deactivated during AMA run.
1	Drive started	Indication for mechanical brake controller that start request has been sent for the drive. A fault will deactivate this signal.
2	Open feedback	Open feedback status from the brake.
3	Closed Feedback	Closed feedback status from the brake.
4..9	Reserved	-
10	Feedback error	Brake feedback error has occurred, that is, feedback signals have changed too late from the command or are in incorrect states when the drive is running.
11	Priming timeout	Brake priming was not completed during the priming time.
12	Releasing timeout	The brake open feedback was not received during the Brake Release Time.
13	Closing timeout	The brake closed feedback was not received during the Brake Close Time.
14	Brake control active	The brake is changing its state from open to closed or vice versa.
15	Brake open command	Status of brake open command signal.

P1.11.2 Mechanical Brake State **No. 3017**

Shows the state of the mechanical brake controller. The indication numbers are presented in following table.

Number	Name	Description
0	Passive off	The brake controller is disabled.
1	Passive open	The brake is open.
2	Passive closed	The brake is closed.
3	Priming	The drive is applying priming torque before releasing.
4	Releasing	The brake is being released.
5	Closing	The brake is closing and priming torque is being applied.
6	Disengaging	The drive is removing the priming torque.
7	Hovering	The drive is holding the load before brake closing.

P1.11.3 Brake Release Time Detected **No. 3041**

Shows the time from brake release until load change is detected, where motor takes over the load from mechanical brake.

7.2.12 Custom Status Word Monitoring

P1.12.1 Custom Status Word **No. 2410**

Shows the status of the Custom Status Word bits 0...15.

7.2.13 Power Unit Monitoring

P1.13.1 Power Capacity **No. 2836**

Shows the power capacity of the drive as percentage. The value is derived from the amount of active power units compared to nominal power unit count of the drive.

P1.13.2 Unit Nominal Voltage No. 2830

Shows the nominal voltage setting as a result of the setting of parameter Unit Voltage Class (No. 2832).

P1.13.3 Unit Nominal Current No. 2831

Shows the nominal current of the unit.

P1.13.4 Heat Sink Temperature No. 2950

Shows the temperature of the power unit heat sink.

P1.13.5 Active Power Unit Mask No. 249

Bit mask that represents which of the power units are active.

NOTICE

This parameter is only visible in drives with star coupler board units.

7.2.14 Rectifier Monitoring

NOTICE

This group is only visible in drives with integrated rectifier units.

P1.14.1 Grid Frequency No. 9041

Shows the actual grid frequency.

P1.14.2 Line-To-Line Voltage (RMS) No. 9040

Shows the average line-to-line voltage (RMS).

P1.14.3 L1-L2 Line Voltage (RMS) No. 9048

Shows the L1-L2 line voltage (RMS).

P1.14.4 L2-L3 Line Voltage (RMS) No. 9049

Shows the L2-L3 line voltage (RMS).

P1.14.5 L3-L1 Line Voltage (RMS) No. 9050

Shows the L3-L1 line voltage (RMS).

P1.14.6 Grid Voltage Imbalance No. 9047

Shows the grid voltage imbalance in %. A value greater than 3% may indicate grid problems.

P1.14.7 Total Harmonic Distortion (THDv) No. 9046

Shows the total harmonic distortion of the grid voltage (THDv) in %.

P1.14.8 Grid Active Power No. 9064

Shows the active power at the point of grid connection.

7.2.15 Advanced Harmonic Filter Monitoring

NOTICE

This group is only visible in drives with integrated rectifier units.

P1.15.1 AHF Capacitor Connected No. 5410

Shows if the advanced harmonic filter (AHF) capacitor is connected.

7.2.16 Fieldbus Process Data Monitoring

P1.16.1 FB PCD Control Word No. 1335

Shows the fieldbus control word process data signal value.

See chapter [2.2 Fieldbus Control Profile Descriptions](#) for detailed descriptions.

P1.16.2 FB PCD Main Reference Value No. 1339

Shows the fieldbus main reference process data signal value.

P1.16.3 FB PCD Status Word No. 1307

Shows the fieldbus status word process data signal value.

See chapter [2.2 Fieldbus Control Profile Descriptions](#) for detailed descriptions.

P1.16.4 FB PCD Main Actual Value No. 1308

Shows the fieldbus main actual process data signal value.

P1.16.5 FB PCD Speed Reference No. 1345

Shows the speed reference fieldbus process data signal value. This is used when CiA-402 is selected as the fieldbus profile.

P1.16.6 FB PCD Torque Reference No. 4543

Shows the torque reference fieldbus process data signal value.

P1.16.7 FB PCD Power Reference No. 4575

Shows the power reference fieldbus process data signal value.

P1.16.8 FB PCD Current Limit No. 3192

Shows the current limit fieldbus process data signal value.

P1.16.9 FB PCD Motor Torque Limit No. 3157

Shows the motor torque limit fieldbus process data signal value.

P1.16.10 FB PCD Regenerating Torque Limit No. 3161

Shows the regenerating torque limit fieldbus process data value.

P1.16.11 FB PCD Motor Power Limit No. 3175

Shows the motor power limit fieldbus process data signal value.

P1.16.12 FB PCD Regenerating Power Limit No. 3176

Shows the regenerating power limit fieldbus process data signal value.

P1.16.13 FB PCD Speed Ref. Adjust No. 4516

Shows the speed reference adjust fieldbus process data signal value.

P1.16.14 FB PCD Overvoltage Limit No. 4512

Shows the DC-link overvoltage limit fieldbus process data signal value.

P1.16.15 FB PCD Undervoltage Limit No. 4510

Shows the DC-link undervoltage limit fieldbus process data signal value.

P1.16.16 FB PCD Power Limit Increase Rate No. 4529

Shows the power limit increase rate fieldbus process data signal value.

P1.16.17 FB PCD Power Ref. Increase Rate No. 4538

Shows the power reference increase rate fieldbus process data signal value.

P1.16.18 FB PCD Power Ref. Decrease Rate No. 4539

Shows the fieldbus power reference decrease rate fieldbus process data signal value.

P1.16.19 FB PCD Operation Control Word No. 4564

Shows the operation control word fieldbus process data signal value. This can be used as an alternative way for commanding the following operations from fieldbus.

Bit No.	Name	Description
0	Open Breaker	Manual command for opening the motor breaker. Operation identical with parameter No. 4706 Breaker Manual Open Input .
1	Close Breaker	Manual command for closing the motor breaker. Operation identical with parameter No. 4705 Breaker Manual Close Input .
2	Force Fieldbus Control	Command for forcing the drive to Fieldbus Control. Operation identical with parameter No. 4511 Force FB Control Input .
3	Force I/O Control	Command for forcing the drive to I/O Control. Operation identical with parameter No. 4513 Force I/O Control Input .
4	Force Advanced Control	Command for forcing the drive to Advanced Control. Operation identical with parameter No. 4721 Force Advanced Control Input .
5	Reserved	-
6	Control Mode Preset Input 1	First input for Preset Control Mode. Operation identical with parameter No. 3469 Control Mode Preset Input 1 .
7	Control Mode Preset Input 2	Second input for Preset Control Mode. Operation identical with parameter No. 3470 Control Mode Preset Input 2 .
8...31	Reserved	-

P1.16.20 FB PCD Master Motor Torque No. 4506

Shows the motor torque from master drive fieldbus process data signal value. Used in the load drooping assist function.

P1.16.21 FB PCD Control Word 2 No. 1347

Shows the control word 2 fieldbus process data signal value.

P1.16.22 FB PCD Status Word 2 No. 1344

Shows the status word 2 fieldbus process data signal value.

P1.16.23 FB PCD Torque Ref. Increase Rate No. 2353

Shows the torque reference increase rate fieldbus process data signal value.

P1.16.24 FB PCD Torque Ref. Decrease Rate No. 2354

Shows the torque reference decrease rate fieldbus process data signal value.

7.2.17 Functional Safety Monitoring**P1.17.1 Functional Safety Status Word No. 2799**

Shows the functional safety status word. The meaning of the bits is described in the following table.

Bit No.	Name	Description
0	STO Active	The Safe Torque Off (STO) is active and stopped the drive. Either both safety input voltages have been removed, or one input voltage has been removed and an I/O failure has activated the STO, or the STO has been activated after an SS1 event.
1	SS1 Active	The Safe Stop 1 (SS1) is active through the first or second instance of SS1 function, and SS1 has been configured to stop with ramp with No. 9901 .
2	SS1 Instance 1 Active	The first instance of SS1 is active.
3	SS1 Instance 2 Active	The second instance of SS1 is active.
4...15	Reserved	-

7.2.18 Date & Time Monitoring**P1.18.1 Date & Time No. 2799**

Shows current system date and time.

P1.18.2 Active NTP Server No. 6230

Shows the currently active Network Time Protocol server IPv4.

P1.18.3 Last Time Received (NTP) No. 6235

Shows the latest received time from the active Network Time Protocol server.

7.2.19 Logic Monitoring**P1.19.1 Logic Speed Reference No. 21110**

Shows Logic speed reference.

P1.19.2 Logic Torque Reference No. 21111

Shows Logic torque reference.

P1.19.3 Logic Power Reference No. 21114

Shows Logic power reference.

P1.19.4 Logic State No. 21094

Shows the current active state in Logic.

No.	Name	Description
0	No State	No state active.
1	State 1	State 1 active.
2	State 2	State 2 active.
3	State 3	State 3 active.
4	State 4	State 4 active.
5	State 5	State 5 active.

P1.19.5 Time in current state No. 21095

Shows the time that the current state in Logic has been active.

P1.19.6 Logic Running Mode No. 21091

Shows the current running mode for Logic.

No.	Name	Description
0	Running	Logic is in execution mode
1	Programming	Logic is in programming mode.
2	Disabled	Logic is disabled. Change to Programming mode to edit the configuration.

7.2.20 Master Follower Monitoring

P1.20.1 Active Master Follower Mode No. 5606

Shows the active master follower mode.

7.2.21 I/O And Relay Status

This group and its subgroups appear only if an I/O And Relay OC7C1 option is included in the drive. This menu appears as many times as there are these options in the system. Each menu and its parameters have the suffix of their option slot.

Refer to 7.7.1.1 I/O And Relay Status for the description of the menu content.

7.2.22 Encoder/Resolver Status

This group and its subgroups appear only if an Encoder/Resolver OC7M0 option is included in the drive. This menu appears as many times as there are these options in the system. Each menu and its parameters have the suffix of their option slot.

Refer to 7.7.2.1 Encoder/Resolver Status for the description of the menu content.

7.2.23 Temperature Measurement Status

This group and its subgroups appear only if a Temperature Measurement OC7T0 option is included in the drive. This menu appears as many times as there are these options in the system. Each menu and its parameters have the suffix of their option slot.

Refer to 7.7.3.1 Temperature Measurement Status for the description of the menu content.

7.3 Parameters

This group houses most of the drive settings.

7.3.1 Basic Parameters

This group contains a collection of the very basic parameters needed to get the drive operational. Motor nominal values, drive nominal values, the motor control principle, and the ability to start the Automatic Motor Adaptation are present in this group.

This group contains the motor nameplate parameters. Setting these parameters identifies the motor for the drive and enables better execution of motor control algorithms.

Besides the motor nameplate parameters, the user can set a value for the nominal DC-link voltage in volts with parameter **No. 2834**. It is used as a basis for calculating the activation limits for the over- and undervoltage protections.

With parameter **No. 420** the user can prime the Automatic Motor Adaptation (AMA), which is an automated test procedure providing optimization of the motor parameters for improved shaft performance. The measurement is performed based on the motor nameplate data. The motor type specific motor characteristics parameters in groups **G2.9.2** and **G2.9.3** are recalculated and used to fine-tune motor control algorithms. Running the AMA procedure also maximizes the performance of the Automatic Energy Optimization (AEO) function.

With parameter **No. 2503** the user can define the motor control principle. The drive can use three different motor control principles: U/f, Voltage Vector Control Plus (VVC+) and Flux Vector Control Plus (FVC+) principles. Note that the principle is automatically changed when selecting the Torque or Power Control Modes.

To optimize drive control, the user should also specify a Unit Voltage Class for the drive with parameter **No. 2832**. Each iC7 power unit is rated for a wide input voltage range which the drive can operate in. This parameter is used to specify a narrower band within that range to determine optimized values for the unit's nominal voltage and current. Specific voltage ranges depend on the unit type.

P2.1.1 Motor Type

No. 407

Select the motor type.

No.	Name	Description
0	Induction Motor	
1	Permanent Magnet Motor	

P2.1.2 Motor Nominal Power

No. 405

Set the motor nominal power.

P2.1.3 Motor Nominal Current

No. 400

Set the motor nominal current.

P2.1.4 Motor Nominal Speed

No. 402

Set the motor nominal speed.

P2.1.5 Motor Nominal Frequency**No. 403**

Set the motor nominal frequency.

NOTICE

- 1) Changing this parameter when fieldbus profile (**No. 1301**) has been set to "iC Generic" automatically updates the following parameters to following values:
 - **No. 6312 Fieldbus Speed Signal Max** to 10000
 - **No. 6313 Fieldbus Speed Signal Min** to -10000
 - **No. 6310 Fieldbus Speed Scale Max** to $2 * \text{Motor Nominal Frequency (No. 403)}$
 - **No. 6311 Fieldbus Speed Scale Min** to $(-2) * \text{Motor Nominal Frequency (No. 403)}$

- 2) Changing this parameter when fieldbus profile (**No. 1301**) has been set to "Speed Profile" automatically updates the following parameters to following values:
 - **No. 6312 Fieldbus Speed Signal Max** to 32767
 - **No. 6313 Fieldbus Speed Signal Min** to -32768
 - **No. 6310 Fieldbus Speed Scale Max** to $2 * \text{Motor Nominal Frequency (No. 403)}$
 - **No. 6311 Fieldbus Speed Scale Min** to $(-2) * \text{Motor Nominal Frequency (No. 403)}$

- 3) Changing this parameter when fieldbus profile (**No. 1301**) has been set to "PROFIdrive® Standard Telegram 1" automatically updates the following parameters to following values:
 - **No. 6312 Fieldbus Speed Signal Max** to 32767
 - **No. 6313 Fieldbus Speed Signal Min** to -32768
 - **No. 6310 Fieldbus Speed Scale Max** to $2 * \text{Motor Nominal Frequency (No. 403)}$
 - **No. 6311 Fieldbus Speed Scale Min** to $(-2) * \text{Motor Nominal Frequency (No. 403)}$

 - **No. 5251 Limit Supervision Signal Number 1** to "Motor Shaft Speed"
 - **No. 5252 Limit Supervision 1 Type** to "Supervise High Limit"
 - **No. 5253 Limit Supervision 1 Threshold** to 100.00 rpm
 - **No. 5255 Limit Supervision 1 Hysteresis** to 0.00 %
 - **No. 5250 Limit Supervision Response 1** to "No response"

P2.1.6 Motor Nominal Voltage**No. 401**

Set the motor nominal voltage.

P2.1.7 DC-link Nominal Voltage**No. 2834**

Set the nominal DC-link voltage. Calculated automatically based on unit nominal voltage when the unit voltage class is changed. Can also be set manually. If set to 0 the unit nominal voltage (peak amplitude) is used.

P2.1.8 AMA Mode**No. 420**

Select the Automatic Motor Adaptation (AMA) mode.

No.	Name	Description
0	Off	AMA is disabled.

Application Guide

No.	Name	Description
3	Motor Data - Standstill	The next start command initiates measurement of the motor data. AMA is run without rotating the motor.
4	Reduced Motor Data (Rs) - Standstill	The next start command initiates measurement of the motor stator resistance - Rs. AMA is run without motor rotation.

NOTICE

- The AMA must be run on a cold motor. Note that also running the AMA multiple times will also increase the motor temperature.
- The AMA needs to be conducted with the motor at standstill. Avoid generating external torque during AMA.
- The AMA cannot run with a sine-wave filter connected. Uncoupling the load from the motor isn't needed.
- The duration of the AMA depends on the power rating of the motor.
- The AMA calculations depend on the motor nameplate values. Define these in group **G2.1** before running the AMA.
- Changing the nameplate data in parameter group will also modify the motor identification data in the groups **G2.9.2** or **G2.9.3**, depending on the motor type. It is recommended to run the AMA after changing the nameplate data.
- The parameter automatically switches back to Off after the AMA has been performed.

P2.1.9 Motor Control Principle

No. 2503

Select the motor control principle.

No.	Name	Description
0	U/f Control	<p>U/f control is used for less demanding applications without slip compensation, where motor data is typically unknown.</p> <p>U/f can operate all motor types in open-loop speed control only.</p> <p>It is most suitable for asynchronous motor operation.</p> <p>The Volts-per-Hertz curve can be user defined with parameters of group G2.9.4.</p> <p>Only usable with the Speed Control Mode.</p>
1	VVC+ Control	<p>VVC+ is a medium performance motor control principle.</p> <p>Enables slip compensation.</p> <p>Does not require detailed motor data (G2.9.2 or G2.9.3).</p> <p>VVC+ support all motor types.</p> <p>It offers closed-loop speed control for asynchronous motors, and open-loop speed control for other motor types.</p> <p>Only usable with the Speed Control Mode.</p>
2	FVC+ Control	<p>FVC+ control provides high performance motor control.</p> <p>It supports all motor types.</p> <p>It can be configured to run Speed, Torque or Power control.</p> <p>Flux control can run with or without resolver/encoder feedback (open-loop or closed-loop speed control).</p> <p>It requires accurate motor data (G2.9.2 or G2.9.3). Running Automatic Motor Adaption prior to Flux control is highly recommended.</p> <p>Mandatory for Torque and Power Control Modes.</p>

P2.1.10 Unit Voltage Class

No. 2832

Select the unit voltage class to optimize the performance of the drive. Each power unit is rated for a wide voltage range which the drive can operate in. This parameter is used to specify a narrower band within that range to determine optimized values for the unit's nominal voltage and current. The DC-link nominal voltage is calculated automatically whenever this parameter is changed.

No.	Name	Description
1	Low-voltage range	<p>Unit nominal voltage and current are set according to the lowest end of the unit's voltage range.</p> <ul style="list-style-type: none"> • For example, for T5-units this range is 380-440 V AC. • For example, for T7-units this range is 525-550 V AC.
2	Mid-voltage range	<p>Unit nominal voltage and current are set according to the middle of the unit's voltage range.</p> <ul style="list-style-type: none"> • For example, for T5-units this range is 440-480 V AC. • For example, for T7-units this range is 550-600 V AC.
3	High-voltage range	<p>Unit nominal voltage and current are set according to the highest end of the unit's voltage range.</p> <ul style="list-style-type: none"> • For example, for T5-units this range is 480-500 V AC. • For example, for T7-units this range is 600-690 V AC.

No.	Name	Description
4	Wide-voltage range	Unit nominal voltage and current are set according to the unit's whole voltage range. <ul style="list-style-type: none"> • For example, for T5-units this range is 380-500 V AC. • For example, for T7-units this range is 525-690 V AC.

P2.1.11 Overload Mode No. 2833

Select the overload mode. Overloading mode selects an overtemperature protection profile for the drive, effecting current limits and protection activation times. With a higher overloading mode, the drive will operate in a greater degree of overloading before protections take effect. Specific limits and activation delays depend on the conditions.

No.	Name	Description
0	Automatic	The drive automatically determines whether to use the Low or High Overload Mode.
1	Low overload (LO)	The drive uses the lower overloading profile. Overtemperature protection is activated with a lesser degree of overload.
2	High overload (HO1)	The drive uses a higher overloading profile. Overtemperature protection is activated with a higher degree of overload.
3	High overload increased duty (HO2)	The drive uses the highest overloading profile. Overtemperature protection is activated with the highest degree of overload.

7.3.2 Control Mode and References

This group contains parameters for configuring the control mode and references for the drive.

7.3.2.1 Control Mode

The application offers the user three different control modes: speed, torque, and power. These modes define whether the main control variable is the motor speed, torque, or power, and whether a speed or torque-based control loop is used to control the drive.

The mode can be set per each control place. If different modes are assigned to different control places, the mode changes whenever the control place is changed.

Additionally, a Preset Mode can be assigned to a control place. When this mode is selected, the mode is yet again set between speed, torque, or power, but the selection is done via a bitwise use of two input signals. These signals can be given via digital inputs or fieldbus signals.

Speed Control

The drive can control the speed of the motor. Both open- and closed-loop speed control is supported depending on the used motor control principle and motor type. The speed reference can be given from various sources and the speed can be limited with parameter settings.

Torque Control

The motor torque can be controlled to a requested level. While controlling the motor torque the motor speed changes according to motor dynamics, loading and speed limiting. This mode is available only in the FVC+ motor control principle. The torque reference and limits can be given from various sources.

Power Control

The motor power can be controlled to a requested level. While controlling the motor power the motor speed and torque change according to motor dynamics, loading and speed limiting. This mode is available only in the FVC+ motor control principle. The power reference and limits can be given from various sources.

7.3.2.1.1 Control Mode Configuration

The application provides the user with a control place specific control mode. When switching from one control place to another, the user can also change between the speed, torque, or power control modes.

P2.2.1.1.1 HMI Control Mode No. 3461

Select the control mode for whenever the control panel or the PC tool are the active control place.

No.	Name	Description
0	Speed Control Mode	Motor speed is the main controlled variable. Available for all control principles.
1	Torque Control Mode	Motor torque is the main controlled variable. Available only with FVC+ control principle. Using this mode will force the drive into the FVC+ principle if drive is stopped. Speed is regulated according to parameter Torque Control Speed Limit (No. 2332) .
2	Power Control Mode	Motor power is the main controlled variable. Available only with FVC+ control principle. Using this mode will force the drive into the FVC+ principle if drive is stopped. Speed is regulated according to parameter Torque Control Speed Limit (No. 2332) .
3	Preset Control Mode	The mode is one of the ones listed in this table, but is defined by one of four presets. The selection of the preset is done with the combination of two inputs signals. The presets and input signals are configured in G2.2.1.2 .

P2.2.1.1.2 Fieldbus Control Mode No. 3462

Select the control mode for whenever Fieldbus is the active control place. Selections are the same as for HMI Control Mode.

P2.2.1.1.3 I/O Control Mode No. 3463

Select the control mode for whenever I/O is the active control place. Selections are the same as for HMI Control Mode.

P2.2.1.1.4 Advanced Control Control Mode No. 3464

Select the control mode for whenever advanced control place is the active control place. Selections are the same as for HMI Control Mode.

7.3.2.1.2 Preset Ctrl Mode

This group allows the user to define four control mode presets. By using two digital input signals or the FB PCD Operation Control Word bits 6 and 7 (**No. 4564**) the user can choose which preset is active. Once "Preset Control" is selected for any of the control places, the user can use the combination of the input signals to choose which preset is active. This allows the user to quickly switch between control modes for a specific control place. The preset signals work in a binary fashion according to the following table.

	Preset Input 1 or FB PCD Operation Control Word bit 6	Preset Input 2 or FB PCD Operation Control Word bit 7
Preset 1 Selected	OFF	OFF
Preset 2 Selected	ON	OFF
Preset 3 Selected	OFF	ON
Preset 4 Selected	ON	ON

P2.2.1.2.1 Control Mode Preset 1 **No. 3465**

Select the control mode for the first control mode preset. This preset is used if the preset mode is selected for the active control place and neither of the 2 selection inputs are active.

No.	Name	Description
0	Speed Control Mode	Motor speed is the main controlled variable. Available for all control principles.
1	Torque Control Mode	Motor torque is the main controlled variable. Available only with FVC+ control principle. Using this mode will force the drive into the FVC+ principle if drive is stopped. Speed is regulated according to parameter Torque Control Speed Limit (No. 2332) .
2	Power Control Mode	Motor power is the main controlled variable. Available only with FVC+ control principle. Using this mode will force the drive into the FVC+ principle if drive is stopped. Speed is regulated according to parameter Torque Control Speed Limit (No. 2332) .

P2.2.1.2.2 Control Mode Preset 2 **No. 3466**

Select the control mode for the second control mode preset. This preset is used if the preset mode is selected for the active control place and the first selection input is active. Selections are the same as for Control Mode Preset 1.

P2.2.1.2.3 Control Mode Preset 3 **No. 3467**

Select the control mode for the third control mode preset. This preset is used if the preset mode is selected for the active control place and the second selection input is active. Selections are the same as for Control Mode Preset 1.

P2.2.1.2.4 Control Mode Preset 4 **No. 3468**

Select the control mode for the fourth control mode preset. This preset is used if the preset mode is selected for the active control place and both of the selection inputs are active. Selections are the same as for Control Mode Preset 1.

P2.2.1.2.5 Control Mode Preset Input 1 No. 3469

Select the first digital input terminal for the selection of the control mode preset.

No.	Name	Description
0	None (False)	No input is selected. A virtual value of FALSE is applied.
1	None (True)	No input is selected. A virtual value of TRUE is applied.
*	Fieldbus control word 1/2 digital input bits	Fieldbus CTW1 digital input bits 12-15 and CTW2 digital input bits 0-15 will be presented as options.
*	Logic Digital I/O virtual terminals	Virtual digital outputs from the Logic Feature function blocks are presented as input options.
*	Available digital input terminals	A dynamically generated selection of available digital input terminals is presented as an option. The specific set depends on the type and number of I/O options installed in the system.

P2.2.1.2.6 Control Mode Preset Input 2 No. 3470

Select the second digital input terminal for the selection of the control mode preset. Selections are the same as for Control Mode Preset Input 1.

7.3.2.2 Speed Reference

This group contains parameters for configuring the drive’s speed reference settings. The following diagram depicts the speed control chain. The reference settings for the I/O control place are fully displayed in the diagram as an example, however similar selector and combining logics are also available for the other control places as well.

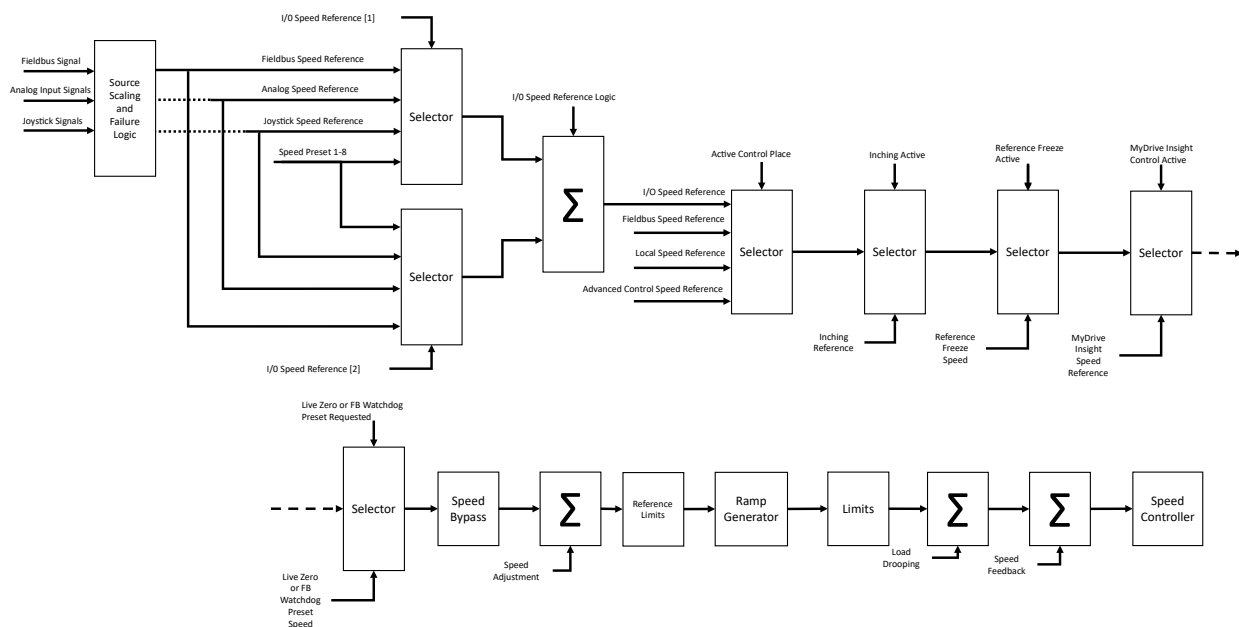

Figure 45: Speed control chain diagram

7.3.2.2.1 Basic Settings

The following group houses the speed reference source selection and scaling parameters. Several sources are available and those can be assigned for each control place individually.

Source Selection:

As an example, for setting up the reference for the I/O control place the following should be done: Use **No. 1913** to select two sources as individual array elements of the parameter. Then, using **No. 1910**, select a combination logic for these two sources. A single source can be selected as is, or the two can be, for example, summed, divided, or the minimum of them can be selected. If the *Toggle*-logic is selected, the selection between the two sources can be made with a digital input signal which can be configured with **No. 1940**.

The same settings can be made for other control places with their respective source selection, source logic and toggle input parameters found within this parameter group.

Signal Scaling:

If one of the analog inputs or the fieldbus signal is selected as a source, the respective scaling signals can be used to interpret the input as a speed signal. For analog signals the maximum and minimum of each terminal can be set in **G9**. Set the corresponding maximum and minimum speed values with parameters **No. 1724-1727**.

For fieldbus the scaling depends of the used fieldbus profile, selected with **No. 1301**. For profiles *iC Generic*, *iC Speed*, and *Profidrive Standard Telegram 1* the drive uses signal **No. 1339** as the speed reference input, and a bidirectional linear scaling is applied. Use **No. 6312** to define the maximum value of the incoming fieldbus signal and then set the corresponding speed value with **No. 6310**. Likewise, set the minimum incoming value with **No. 6313** and the corresponding speed value with **No. 6311**. If *CiA-402 Velocity Mode* is selected as the fieldbus profile, signal **No. 1345** is used as the speed reference input. The limits are defined with **No. 6310 and No. 6311**.

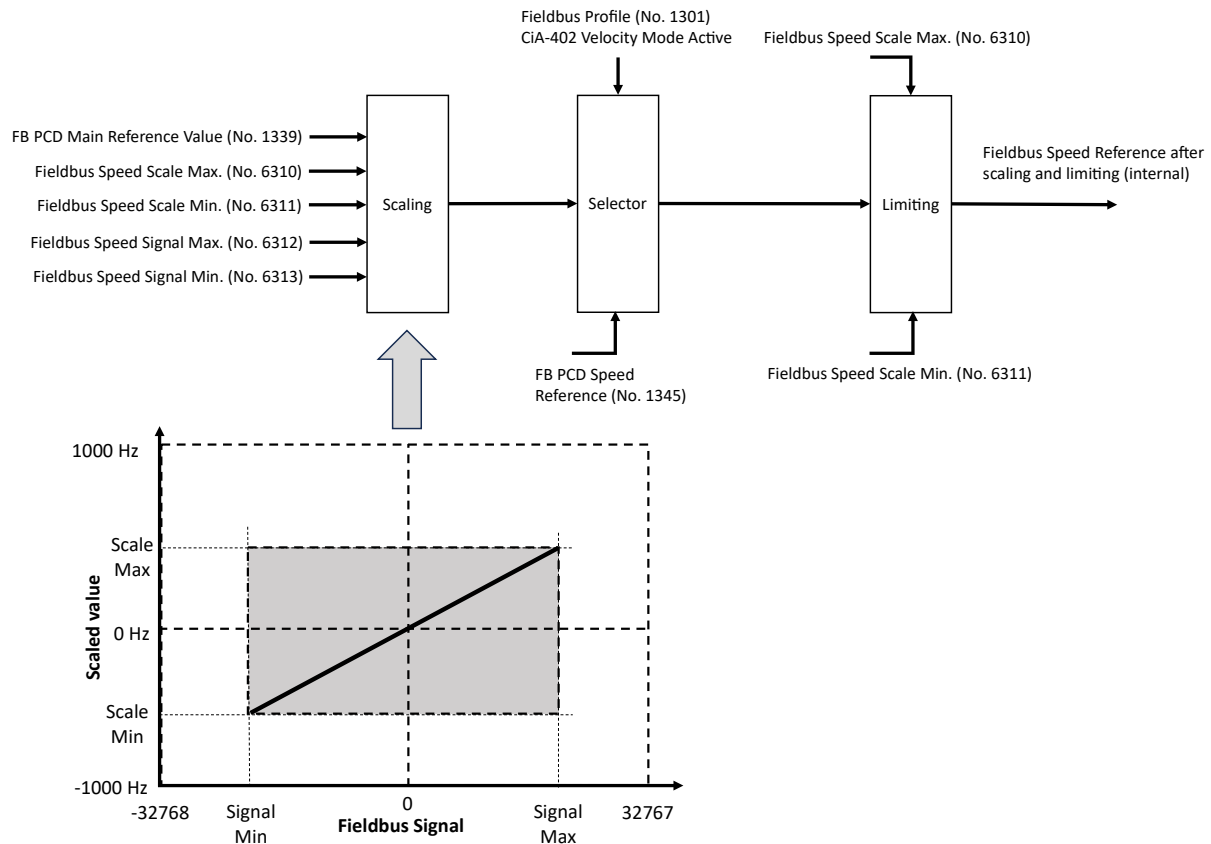

Figure 46: Scaling of fieldbus speed reference.

NOTICE

The fieldbus signal scaling also applies to the interpretation of the fieldbus main actual value. Whenever the fieldbus profile (**No. 1301**) is set to *iC Speed* or *PROFdrive® Standard Telegram 1* the scaling is automatically set for input values +32767/-32768 to correspond to speed values of +199.99%/-200.00% of motor nominal speed. For *iC Generic* the scaling is set to +10000/-10000 and +199.99%/-200.00%. Scaling is also set when the *iC Generic*, *iC Speed*, or *PROFdrive® Standard Telegram 1* profile is in use and **Motor Nominal Frequency (No. 403)** is changed.

Response to Signal Failure:

In case of a signal failure (Live Zero event for analog signals and Fieldbus Watchdog event for fieldbus signals) the signal is no longer healthy. In this case the user can use the signal respective parameters (**No. 4591-4593**) to select a desirable response. The unhealthy signal can be replaced with a preset value defined with parameter **No. 4594** or the previous value of the respective signal which was seen 10 seconds before the failure event.

P2.2.2.1.1 I/O Speed Reference No. 1913

Select the speed reference sources for when the drive operates in I/O control. Two sources are available (Index 0 and Index 1), which can be combined into 1 reference value with parameter **No. 1910**.

No.	Name	Description
0	None	No source is selected.

No.	Name	Description
		A reference of zero is provided.
2	Fieldbus reference	The reference is obtained from the fieldbus main reference value (No. 1339). Set the scaling of the value with parameters No. 6310-6313 . Select how to respond if this signal fails with No. 4593 .
3	Reference 1 input	The reference is obtained from the analog speed reference 1. Select the analog terminal with No. 501 . Set the scaling of the signal with No. 1724 and No. 1725 . Select how to respond if this signal fails with No. 4591 .
4	Reference 2 input	The reference is obtained from the analog speed reference 2. Select the analog terminal with No. 502 . Set the scaling of the signal with No. 1726 and No. 1727 . Select how to respond if this signal fails with No. 4592 .
5	Preset reference	The reference is obtained from the Preset Speed Reference feature. Further configure this source in G2.2.2.3 .
6	Joystick 1	The reference is obtained from the Joystick 1 function. Further configure this signal in G2.2.5 .
7	Joystick 2	The reference is obtained from the Joystick 2 function. Further configure this signal in G2.2.5 .
9	Logic Reference	The reference is obtained from the logic feature. Refer to the <i>MyDrive® Insight Logic Feature Application Guide</i> for configuration information.

P2.2.2.1.2 I/O Speed Reference Logic **No. 1910**

Select how to form the speed reference out of the 2 sources when operating in I/O control.

No.	Name	Description
0	Source 1	Use the first of the two source inputs
1	Source 2	Use the second of the two source inputs
2	Sum	Source 1 + Source 2
3	Subtract	Source 1 - Source 2
4	Divide	Source 1 / Source 2 Note: When dividing by zero, the reference is set to its maximum.
5	Multiply	Source 1 * Source 2 Note: The reference is saturated at +/- its maximum.
6	Maximum	Use whichever source is greater in value at the time.
7	Minimum	Use whichever source is smaller in value at the time.
8	Toggle	Use an input to toggle between Source 1 and 2 with the respective digital input signal. With low input signal Source 1 is selected, and with high input signal Source 2 is selected.

P2.2.2.1.3 I/O Speed Reference Toggle Input **No. 1940**

Select an input for toggling between the 2 speed reference sources selected, when operating in I/O control and toggling logic is used. A low signal selects the 1st source and high signal selects the 2nd source.

No.	Name	Description
0	None (False)	No input is selected. A virtual value of FALSE is applied.
1	None (True)	No input is selected. A virtual value of TRUE is applied.
*	Fieldbus control word 1/2 digital input bits	Fieldbus CTW1 digital input bits 12-15 and CTW2 digital input bits 0-15 will be presented as options.
*	Logic Digital I/O virtual terminals	Virtual digital outputs from the Logic Feature function blocks are presented as input options.
*	Available digital input terminals	A dynamically generated selection of available digital input terminals is presented as an option. The specific set depends on the type and number of I/O options installed in the system.

P2.2.2.1.4 Fieldbus Speed Reference No. 1914

Select the speed reference sources for when the drive operates in fieldbus control. Select 2 sources to combine them into 1 reference value with parameter **No. 1911**. Selections are the same as for I/O Speed Reference.

P2.2.2.1.5 Fieldbus Speed Reference Logic No. 1911

Select how to form the speed reference out of the 2 inputs when operating in fieldbus control. Selections are the same as for I/O Speed Reference Logic.

P2.2.2.1.6 Fieldbus Speed Reference Toggle Input No. 1939

Select an input for toggling between the 2 speed reference sources selected, when operating in fieldbus control and toggling logic is used. A low signal selects the 1st source and high signal selects the 2nd source. Selections are the same as for I/O Speed Reference Toggle Input.

P2.2.2.1.7 Adv. Speed Reference No. 1915

Select the speed reference sources for when the drive operates in advanced control. Select 2 sources to combine them into 1 reference value with parameter **No. 1916**. Selections are the same as for I/O Speed Reference.

P2.2.2.1.8 Adv. Speed Reference Logic No. 1916

Select how to form the speed reference out of the 2 sources when operating in advanced control. Selections are the same as for I/O Speed Reference Logic.

P2.2.2.1.9 Adv. Speed Reference Toggle Input No. 1941

Select an input for toggling between the 2 speed reference sources selected, when operating in advanced control and toggling logic is used. A low signal selects the 1st source and high signal selects the 2nd source. Selections are the same as for I/O Speed Reference Toggle Input.

P2.2.2.1.10 Local Speed Ref. Source No. 1912

Select the speed reference source for when the drive is in local control.

No.	Name	Description
1	Local Reference	The reference given with the control panel is used. Also, parameter No. 6153 can be used to give the reference.
2	Fieldbus reference	The reference is obtained from the fieldbus main reference value (No. 1339). Set the scaling of the value with parameters No. 6310-6313 . Select how to respond if this signal fails with No. 4593 .

No.	Name	Description
3	Reference 1 input	The reference is obtained from the analog speed reference 1. Select the analog terminal with No. 501 . Set the scaling of the signal with No. 1724 and No. 1725 . Select how to respond if this signal fails with No. 4591 .
4	Reference 2 input	The reference is obtained from the analog speed reference 2. Select the analog terminal with No. 502 . Set the scaling of the signal with No. 1726 and No. 1727 . Select how to respond if this signal fails with No. 4592 .
5	Preset reference	The reference is obtained from the Preset Speed Reference feature. Further configure this source in G2.2.2.3 .
6	Joystick 1	The reference is obtained from the Joystick 1 function. Further configure this signal in G2.2.5 .
7	Joystick 2	The reference is obtained from the Joystick 2 function. Further configure this signal in G2.2.5 .
9	Logic Reference	The reference is obtained from the logic feature. Refer to the <i>MyDrive® Insight Logic Feature Application Guide</i> for configuration information.

P2.2.2.1.11 Control Panel Speed Reference No. 6153

Shows and selects the value of the control panel speed reference.

P2.2.2.1.12 Speed Reference 1 Input No. 501

Select the input terminal or a predefined fixed value for the speed reference.

No.	Name	Description
0	None	No input is selected and a value of 0% is applied to the associated function.
5	50 %	A virtual value of 50 % is applied to the associated function.
10	100 %	A virtual value of 100 % is applied to the associated function.
*	Available analog input terminals	A dynamically generated selection of available analog input terminals is presented as an option. The specific set depends on the type and number of I/O options installed in the system.

P2.2.2.1.13 Speed Reference 1 Max. No. 1724

Set the maximum value of the reference. It defines the upper point for the scaling of the reference input.

P2.2.2.1.14 Speed Reference 1 Min. No. 1725

Set the minimum value of the reference. It defines the lower point for the scaling of the reference input.

P2.2.2.1.15 Speed Ref. 1 Input Failure Response No. 4591

Set the response to a live zero situation for speed reference 1 input. This will affect if the value of the selected terminal goes below its Live Zero Threshold.

No.	Name	Description
0	No response	The reference will be taken from the input terminal regardless of the failure.
1	Preset	The preset reference set with parameter No. 4594 is used.
2	Previous	The reference seen 10 seconds before the failure event is used.

P2.2.2.1.16 Speed Reference 2 Input No. 502

Select the input terminal or a predefined fixed value for the speed reference.

No.	Name	Description
0	None	No input is selected and a value of 0% is applied to the associated function.
5	50 %	A virtual value of 50 % is applied to the associated function.
10	100 %	A virtual value of 100 % is applied to the associated function.
*	Available analog input terminals	A dynamically generated selection of available analog input terminals is presented as an option. The specific set depends on the type and number of I/O options installed in the system.

P2.2.2.1.17 Speed Reference 2 Max. No. 1726

Set the maximum value of the reference. It defines the upper point for the scaling of the reference input.

P2.2.2.1.18 Speed Reference 2 Min. No. 1727

Set the minimum value of the reference. It defines the lower point for the scaling of the reference input.

P2.2.2.1.19 Speed Ref. 2 Input Failure Response No. 4592

Set the response to a live zero situation for speed reference 2 input. This will affect if the value of the selected terminal goes below its Live Zero Threshold.

No.	Name	Description
0	No response	The reference will be taken from the input terminal regardless of the failure.
1	Preset	The preset reference set with parameter No. 4594 is used.
2	Previous	The reference seen 10 seconds before the failure event is used.

P2.2.2.1.20 Fieldbus Speed Signal Max No. 6312

Defines a maximum value for the received speed reference signal and transferred actual speed signal for fieldbus. Use the interpretation parameter to define a corresponding maximum speed value. Note that this parameter limits the actual speed signal.

P2.2.2.1.21 Fieldbus Speed Signal Min No. 6313

Defines a minimum value for the received speed reference signal and transferred actual speed signal for fieldbus. Use the interpretation parameter to define a corresponding minimum speed value. Note that this parameter limits the actual speed signal.

P2.2.2.1.22 Fieldbus Speed Scale Max No. 6310

Defines how the drive interprets the maximum value of the incoming speed reference and outgoing actual speed signals as a speed value. Note that this parameter also limits the fieldbus reference.

P2.2.2.1.23 Fieldbus Speed Scale Min No. 6311

Defines how the drive interprets the minimum value of the incoming speed reference and outgoing actual speed signals as a speed value. Note that his parameter also limits the fieldbus reference.

P2.2.2.1.24 Speed Ref. Fieldbus Failure Response No. 4593

Set the response to a fieldbus communication error (fieldbus fault, process data timeout or fieldbus watchdog) for fieldbus speed reference. This will affect if one of the fieldbus communication errors is detected and the response for the error is set to warning.

No.	Name	Description
0	No response	The reference will be taken from the fieldbus regardless of the failure.
1	Preset	The preset reference set with parameter No. 4594 is used.
2	Previous	The reference seen 10 seconds before the failure event is used.

P2.2.2.1.25 Speed Ref. Failure Preset No. 4594

Set a preset speed for when an analog input live zero event or fieldbus communication warning has been detected, and the response has been selected to use this preset.

P2.2.2.1.26 Speed Ref. Filter Tc No. 1719

Set the time constant of the reference filter. Set to 0 disables the filter.

7.3.2.2.2 Reference Freeze

The reference freeze provides the ability to freeze the active reference with an input signal and to increase/decrease the reference by using two other input signals (digital potentiometer). Independent ramp times, delays, and speed steps can be configured for this feature. After starting up or after power cycling the drive, the reference for the freeze feature is set to either the latest registered freeze reference or to the minimum speed of the drive.

Please note that this feature is a bypass of all typical speed reference sources. The freeze is applied regardless of what source or control place is providing the speed reference.

Note also that the reference freeze acts before the speed ramp generator. The drive's output is ramped, even if the reference would be stepped or maxed by this function.

The digital potentiometer functionality of the reference freeze has three different modes: Step Mode, Ramp Mode, and their combination. In the Step Mode the reference is cumulatively changed by the defined step delta each time a rising edge of the increase or decrease input is registered. This mode is designed for pulse-wise inputs. In the Ramp Mode, the reference is maxed out for as long as the increase or decrease input is active. This results in a continuously increasing or decreasing output, until speed limits are met. This mode is designed for push and release inputs. The combined mode steps the reference with rising edges of the inputs and after a delay time maxes out the reference.

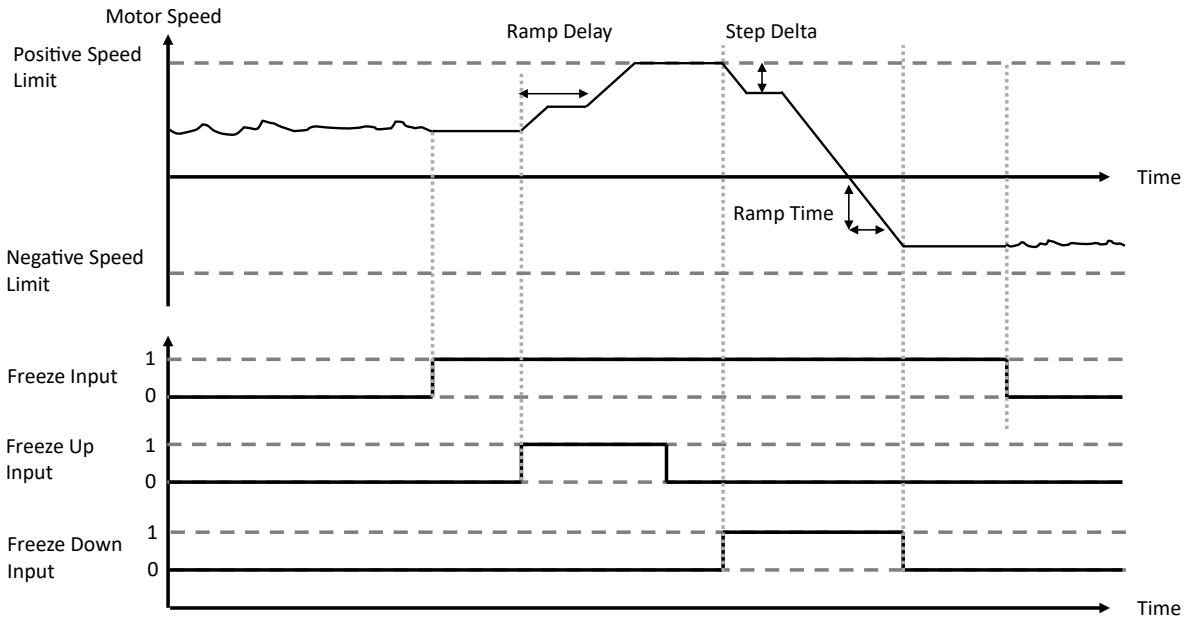

Figure 47: Reference Freeze behavior diagram.

P2.2.2.2.1 Freeze Input No. 1008

Select the digital input for freezing the reference. Freezing is used to control the speed reference with 2 digital inputs, 1 increasing the reference and the other decreasing the reference.

No.	Name	Description
0	None (False)	No input is selected. A virtual value of FALSE is applied.
1	None (True)	No input is selected. A virtual value of TRUE is applied.
*	Fieldbus control word 1/2 digital input bits	Fieldbus CTW1 digital input bits 12-15 and CTW2 digital input bits 0-15 will be presented as options.
*	Logic Digital I/O virtual terminals	Virtual digital outputs from the Logic Feature function blocks are presented as input options.
*	Available digital input terminals	A dynamically generated selection of available digital input terminals is presented as an option. The specific set depends on the type and number of I/O options installed in the system.

P2.2.2.2.2 Freeze Up Input **No. 1001**

Select the digital input for increasing the reference while reference freezing is activated.

No.	Name	Description
0	None (False)	No input is selected. A virtual value of FALSE is applied.
1	None (True)	No input is selected. A virtual value of TRUE is applied.
*	Fieldbus control word 1/2 digital input bits	Fieldbus CTW1 digital input bits 12-15 and CTW2 digital input bits 0-15 will be presented as options.
*	Logic Digital I/O virtual terminals	Virtual digital outputs from the Logic Feature function blocks are presented as input options.
*	Available digital input terminals	A dynamically generated selection of available digital input terminals is presented as an option. The specific set depends on the type and number of I/O options installed in the system.

P2.2.2.2.3 Freeze Down Input **No. 1002**

Select the digital input for decreasing the reference while reference freezing is activated.

No.	Name	Description
0	None (False)	No input is selected. A virtual value of FALSE is applied.
1	None (True)	No input is selected. A virtual value of TRUE is applied.
*	Fieldbus control word 1/2 digital input bits	Fieldbus CTW1 digital input bits 12-15 and CTW2 digital input bits 0-15 will be presented as options.
*	Logic Digital I/O virtual terminals	Virtual digital outputs from the Logic Feature function blocks are presented as input options.
*	Available digital input terminals	A dynamically generated selection of available digital input terminals is presented as an option. The specific set depends on the type and number of I/O options installed in the system.

P2.2.2.2.4 Freeze Ramp Time **No. 1003**

Set the ramp time for increasing/decreasing the reference while reference freeze is active.

P2.2.2.2.5 Freeze Ramp Delay **No. 1004**

Set the delay before ramping the reference while reference freeze is active.

P2.2.2.2.6 Freeze Step Delta **No. 1005**

Set the reference step for increasing/decreasing the reference while reference freeze is active.

P2.2.2.2.7 Freeze Initialization **No. 1006**

Enables freeze initialization. If enabled, freeze reference is initialized to the minimum speed after start-up or a start signal is applied. If disabled, the latest value is used.

No.	Name	Description
0	Disabled	
1	Enabled	

P2.2.2.2.8 Freeze Ramp/Step Mode **No. 1007**

Select how to increase or decrease the reference while reference freeze is active.

No.	Name	Description
0	Step and Ramp	Apply first a step increment and thereafter apply a ramp.
1	Ramp	Apply ramp increment.
2	Step	Apply step increment.

7.3.2.2.3 Speed Reference Presets

The speed reference preset function is a possible speed reference source. The user can define eight different preset values with parameters **No. 703-710**. Once defined the user can select which preset is active either directly with the parameter **No. 702**, or with the binary combination of three digital input signals. The terminals of these signals can be defined with parameters **No. 711-713**. The digital input selection of the presets can be made as shown by the following table.

	BIT 0 Input (No. 711)	BIT 1 Input (No. 712)	BIT 2 Input (No. 713)
Preset 1 (No. 703)	OFF	OFF	OFF
Preset 2 (No. 704)	ON	OFF	OFF
Preset 3 (No. 705)	OFF	ON	OFF
Preset 4 (No. 706)	ON	ON	OFF
Preset 5 (No. 707)	OFF	OFF	ON
Preset 6 (No. 708)	ON	OFF	ON
Preset 7 (No. 709)	OFF	ON	ON
Preset 8 (No. 710)	ON	ON	ON

P2.2.2.3.1 Preset Speed Reference Selector **No. 702**

Select the preset reference. The preset reference can be selected as a fixed value, or when set to Bit Selection, with 3 digital inputs (parameter **No. 711-713**).

No.	Name	Description
0	Bit Selection	Use the Preset Speed Reference Bit 0-2 Inputs to select the preset reference.
1	Preset 1	Use Preset 1
2	Preset 2	Use Preset 2
3	Preset 3	Use Preset 3
4	Preset 4	Use Preset 4
5	Preset 5	Use Preset 5
6	Preset 6	Use Preset 6
7	Preset 7	Use Preset 7
8	Preset 8	Use Preset 8

P2.2.2.3.2 Preset Speed 1 **No. 703**

Set the value of the preset reference.

P2.2.2.3.3 Preset Speed 2 **No. 704**

Set the value of the preset reference.

P2.2.2.3.4 Preset Speed 3 No. 705

Set the value of the preset reference.

P2.2.2.3.5 Preset Speed 4 No. 706

Set the value of the preset reference.

P2.2.2.3.6 Preset Speed 5 No. 707

Set the value of the preset reference.

P2.2.2.3.7 Preset Speed 6 No. 708

Set the value of the preset reference.

P2.2.2.3.8 Preset Speed 7 No. 709

Set the value of the preset reference.

P2.2.2.3.9 Preset Speed 8 No. 710

Set the value of the preset reference.

P2.2.2.3.10 Preset Speed Reference Bit 0 Input No. 711

Select the digital input used as bit 0 addressing the preset reference.

No.	Name	Description
0	None (False)	No input is selected. A virtual value of FALSE is applied.
1	None (True)	No input is selected. A virtual value of TRUE is applied.
*	Fieldbus control word 1/2 digital input bits	Fieldbus CTW1 digital input bits 12-15 and CTW2 digital input bits 0-15 will be presented as options.
*	Logic Digital I/O virtual terminals	Virtual digital outputs from the Logic Feature function blocks are presented as input options.
*	Available digital input terminals	A dynamically generated selection of available digital input terminals is presented as an option. The specific set depends on the type and number of I/O options installed in the system.

P2.2.2.3.11 Preset Speed Reference Bit 1 Input No. 712

Select the digital input used as bit 1 for addressing the preset reference. Selections are identical with the Preset Speed Reference Bit 0 Input.

P2.2.2.3.12 Preset Speed Reference Bit 2 Input No. 713

Select the digital input used as bit 2 for addressing the preset reference. Selections are identical with the Preset Speed Reference Bit 0 Input.

7.3.2.2.4 Speed Reference Adjustment

The reference adjustment feature can be used to fine tune the speed reference. The adjustment is added to the reference right before ramping, and it is relative to the defined minimum and maximum adjustment and the prevalent speed reference.

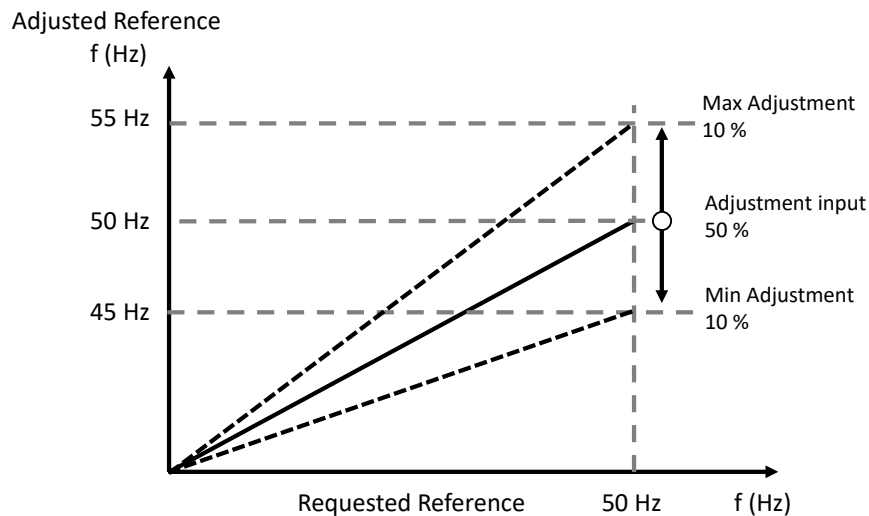

Figure 48: Speed reference adjustment definition.

The preceding figure presents an example of the function. In the figure both the minimum and maximum adjustment have been set to 10 %, which at a requested 50 Hz would correspond to +/- 5 Hz. When the adjustment input is at 50 % the reference is not changed at all. The closer the input is towards 0 % or 100 %, the more the adjustment reduces or increases the reference respectively. Likewise, the greater the requested reference is, the greater the absolute adjustment is. For example, at a requested 25 Hz the 10 % maximum and minimum adjustment would correspond only to +/- 2.5 Hz

P2.2.2.4.1 Adjustment Source Selection **No. 4514**

Select the source for the speed adjustment signal.

No.	Name	Description
0	Not Used	Reference adjustment is not used.
1	Analog Input	Analog Input is used for adjustment.
2	Fieldbus	Fieldbus (param No. 4516) is used for adjustment.

P2.2.2.4.2 Analog Adjustment Input **No. 4515**

Select an input terminal if analog input is used as the adjustment source.

No.	Name	Description
0	None	No input is selected and a value of 0% is applied to the associated function.
5	50 %	A virtual value of 50 % is applied to the associated function.
10	100 %	A virtual value of 100 % is applied to the associated function.
*	Available analog input terminals	A dynamically generated selection of available analog input terminals is presented as an option. The specific set depends on the type and number of I/O options installed in the system.

P2.2.2.4.3 Max. Speed Adjustment **No. 4517**

Set the maximum percentage for speed adjustment.

P2.2.2.4.4 Min. Speed Adjustment **No. 4518**

Set the minimum percentage for speed adjustment.

P2.2.2.4.5 Speed Step Adjustment **No. 4519**

Set a speed reference step after the ramp. Can be used to give an offset to the reference or a step impulse for testing the speed controller tuning.

CAUTION

Sudden speed steps can cause instantaneously high torque. Also note, that the step must be removed to be able to stop modulation, when using ramp stops. Use with care.

NOTICE

This parameter is not used if load drooping assist is in use.

7.3.2.2.5 Speed Bypass

Speed bypass allows the user to set limits for prohibited speed regions, that is, bypass bands. This feature can be used to avoid operating in speed regions that cause resonance in the system.

When the absolute speed reference is increased, the output speed is kept at the low limit until the input reference is above the high limit. Likewise, when the reference is decreased below the high limit, the output is kept at the high limit until the reference is below the low limit. When needing to cross a bypass band, a specific ramping time can be used, to quickly get past a bypass band.

Four separate bands can be configured. The bands are defined using absolute values, but they work symmetrically for both rotation directions.

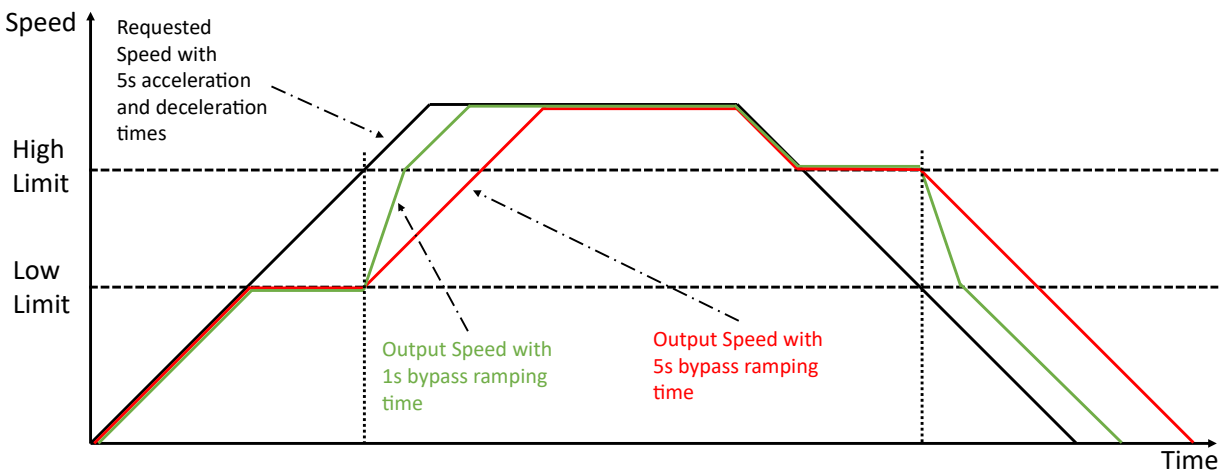

Figure 49: Speed bypass definition.

P2.2.2.5.1 Band 1, Low Limit **No. 4520**

Set the bypass hysteresis speed band, low limit.

P2.2.2.5.2 Band 1, High Limit **No. 4521**

Set the bypass hysteresis speed band, high limit.

P2.2.2.5.3 Band 2, Low Limit No. 4522

Set the bypass hysteresis speed band, low limit.

P2.2.2.5.4 Band 2, High Limit No. 4523

Set the bypass hysteresis speed band, high limit.

P2.2.2.5.5 Band 3, Low Limit No. 4524

Set the bypass hysteresis speed band, low limit.

P2.2.2.5.6 Band 3, High Limit No. 4525

Set the bypass hysteresis speed band, high limit.

P2.2.2.5.7 Band 4, Low Limit No. 4526

Set the bypass hysteresis speed band, low limit.

P2.2.2.5.8 Band 4, High Limit No. 4527

Set the bypass hysteresis speed band, high limit.

P2.2.2.5.9 Bypass Ramp Time No. 4528

Speed ramping time for when motor speed enters any bypass band.

7.3.2.3 Torque Reference

This group contains parameters for configuring the drive's torque reference settings. The following diagram depicts the control chain. The reference settings for the I/O control place are fully displayed in the diagram as an example, however similar selector and combining logics are also available for the other control places as well.

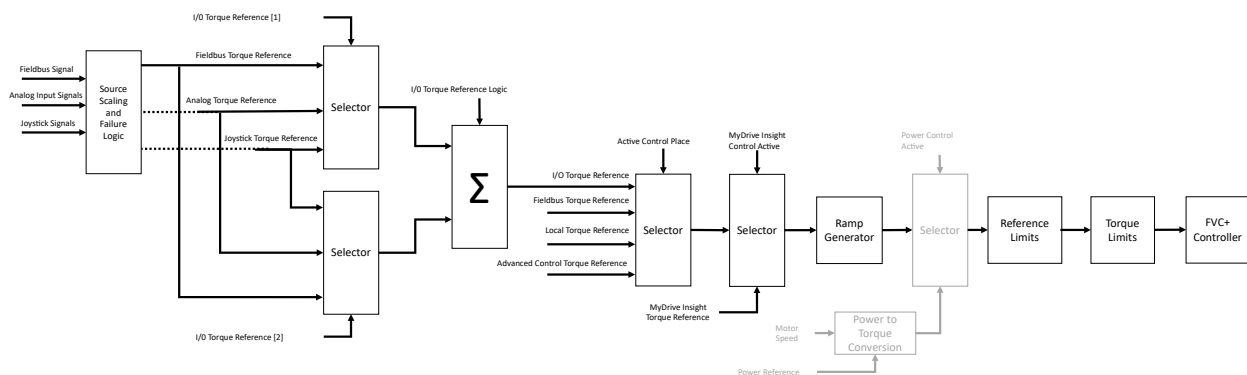

Figure 50: Torque control chain diagram

Source Selection:

As an example, for setting up the reference for the I/O control place the following should be done: Use **No. 1927** to select two sources as individual array elements of the parameter. Then using **No. 1917** select a combination logic for these two sources. A single source can be selected as is, or the two can be, for example, summed, divided, or the minimum of them can be selected.

The same settings can be made for other control places with their respective source selection and source logic parameters found within this parameter group.

Signal Scaling:

If one of the analog inputs is selected as the source the respective scaling signals can be used to interpret the input as a torque signal. For analog signals the maximum and minimum of each terminal can be set in **G9**. Set the corresponding maximum and minimum torque values with parameters **No. 4530** and **No. 4531**.

Response to Signal Failure:

In case of a signal failure (Live Zero event for analog signals and Fieldbus Watchdog event for fieldbus signals) the signal is no longer healthy. In this case, the signal respective parameters (**No. 4595-4597**) can be used to select a desirable response. The unhealthy signal can be replaced with a preset value defined with parameter **No. 4603** or the previous value of the respective signal which was seen 10 seconds before the failure event.

P2.2.3.1 I/O Torque Reference No. 1927

Select the torque reference sources for when the drive operates in I/O control. Two sources are available (Index 0 and Index 1), which can be combined into 1 reference value with parameter **No. 1917**.

No.	Name	Description
0	None	No source is selected. A reference of zero is provided.
2	Fieldbus reference	The reference is obtained from the fieldbus torque reference value (No. 4543). Select how to respond if this signal fails with No. 4597 .
3	Reference 1 input	The reference is obtained from the analog torque reference 1. Select the analog terminal with No. 4534 . Set the scaling of the signal with No. 4530 and No. 4531 . Select how to respond if this signal fails with No. 4595 .
4	Reference 2 input	The reference is obtained from the analog torque reference 2. Select the analog terminal with No. 1923 . Set the scaling of the signal with No. 4532 and No. 4533 . Select how to respond if this signal fails with No. 4596 .
6	Joystick 1	The reference is obtained from the Joystick 1 function. Further configure this signal in G2.2.5 .
7	Joystick 2	The reference is obtained from the Joystick 2 function. Further configure this signal in G2.2.5 .
9	Logic Reference	The reference is obtained from the logic feature. Refer to the <i>MyDrive® Insight Logic Feature Application Guide</i> for configuration information.

P2.2.3.2 I/O Torque Reference Logic No. 1917

Select how to form the torque reference out of the 2 sources when operating in I/O control.

No.	Name	Description
0	Source 1	Use the first of the two source inputs
1	Source 2	Use the second of the two source inputs
2	Sum	Source 1 + Source 2

No.	Name	Description
3	Subtract	Source 1 - Source 2
4	Divide	Source 1 / Source 2 Note: When dividing by zero, the reference is set to its maximum.
5	Multiply	Source 1 * Source 2 Note: The reference is saturated at +/- its maximum.
6	Maximum	Use whichever source is greater in value at the time.
7	Minimum	Use whichever source is smaller in value at the time.
8	Toggle	Use an input to toggle between Source 1 and 2 with the respective digital input signal. With low input signal Source 1 is selected, and with high input signal Source 2 is selected.

P2.2.3.3 Fieldbus Torque Reference No. 1928

Select the torque reference sources for when the drive operates in fieldbus control. Two sources are available (Index 0 and Index 1), which can be combined into 1 reference value with parameter **No. 1918**. Selections are the same as for I/O Torque Reference.

P2.2.3.4 Fieldbus Torque Reference Logic No. 1918

Select how to form the torque reference out of the 2 sources when operating in fieldbus control. Selections are the same as for I/O Torque Reference Logic.

P2.2.3.5 Adv. Torque Reference No. 1929

Select the torque reference sources for when the drive operates in advanced control. Two sources are available (Index 0 and Index 1), which can be combined into 1 reference value with parameter **No. 1919**. Selections are the same as for I/O Torque Reference.

P2.2.3.6 Adv. Torque Reference Logic No. 1919

Select how to form the torque reference out of the 2 inputs when operating in advanced control. Selections are the same as for I/O Torque Reference Logic.

P2.2.3.7 Local Torque Ref. Source No. 1925

Select the torque reference source for when the drive is in local control.

No.	Name	Description
1	Local Reference	The reference given with the control panel is used. Also, parameter No. 6155 can be used to give the reference.
2	Fieldbus reference	The reference is obtained from the fieldbus torque reference value (No. 4543). Select how to respond if this signal fails with No. 4597 .
3	Reference 1 input	The reference is obtained from the analog torque reference 1. Select the analog terminal with No. 4534 . Set the scaling of the signal with No. 4530 and No. 4531 . Select how to respond if this signal fails with No. 4595 .
4	Reference 2 input	The reference is obtained from the analog torque reference 2. Select the analog terminal with No. 1923 . Set the scaling of the signal with No. 4532 and No. 4533 . Select how to respond if this signal fails with No. 4596 .
6	Joystick 1	The reference is obtained from the Joystick 1 function.

No.	Name	Description
		Further configure this signal in G2.2.5 .
7	Joystick 2	The reference is obtained from the Joystick 2 function. Further configure this signal in G2.2.5 .
9	Logic Reference	The reference is obtained from the logic feature. Refer to the <i>MyDrive® Insight Logic Feature Application Guide</i> for configuration information.

P2.2.3.8 Local Torque Reference No. 6155

Shows and selects the value of the control panel torque reference.

P2.2.3.9 Torque Reference 1 Input No. 4534

Select the input terminal for torque reference 1.

No.	Name	Description
0	None	No input is selected and a value of 0% is applied to the associated function.
5	50 %	A virtual value of 50 % is applied to the associated function.
10	100 %	A virtual value of 100 % is applied to the associated function.
*	Available analog input terminals	A dynamically generated selection of available analog input terminals is presented as an option. The specific set depends on the type and number of I/O options installed in the system.

P2.2.3.10 Torque Reference 1 Max No. 4530

Set the torque reference 1 maximum in % of motor nominal torque. The set torque corresponds to input 1 maximum voltage/current.

P2.2.3.11 Torque Reference 1 Min No. 4531

Set the torque reference 1 minimum in % of motor nominal torque. The set torque corresponds to input 1 minimum voltage/current.

P2.2.3.12 Torque Reference 2 Input No. 1923

Select the input terminal for torque reference 2.

No.	Name	Description
0	None	No input is selected and a value of 0% is applied to the associated function.
5	50 %	A virtual value of 50 % is applied to the associated function.
10	100 %	A virtual value of 100 % is applied to the associated function.
*	Available analog input terminals	A dynamically generated selection of available analog input terminals is presented as an option. The specific set depends on the type and number of I/O options installed in the system.

P2.2.3.13 Torque Reference 2 Max No. 4532

Set the torque reference 2 maximum in % of motor nominal torque. The set torque corresponds to input 2 maximum voltage/current.

P2.2.3.14 Torque Reference 2 Min No. 4533

Set the torque reference 2 minimum in % of motor nominal torque. The set torque corresponds to input 2 minimum voltage/current.

P2.2.3.15 Torque Ref. 1 Input Failure Response No. 4595

Set the response to a live zero situation for torque reference 1 input. This will affect if the value of the selected terminal goes below its Live Zero Threshold.

No.	Name	Description
0	No response	The reference will be taken from the input terminal regardless of the failure.
1	Preset	The preset reference set with parameter No. 4603 is used.
2	Previous	The reference seen 10 seconds before the failure event is used.

P2.2.3.16 Torque Ref. 2 Input Failure Response No. 4596

Set the response to a live zero situation for torque reference 2 input. This will affect if the value of the selected terminal goes below its Live Zero Threshold.

No.	Name	Description
0	No response	The reference will be taken from the input terminal regardless of the failure.
1	Preset	The preset reference set with parameter No. 4603 is used.
2	Previous	The reference seen 10 seconds before the failure event is used.

P2.2.3.17 Torque Ref. Fieldbus Failure Response No. 4597

Set the response to a fieldbus communication error (fieldbus fault, process data timeout or fieldbus watchdog) for fieldbus torque reference. This will affect if one of the fieldbus communication errors is detected and the response for the error is set to warning.

No.	Name	Description
0	No response	The reference will be taken from the fieldbus regardless of the failure.
1	Preset	The preset reference set with parameter No. 4603 is used.
2	Previous	The reference seen 10 seconds before the failure event is used.

P2.2.3.18 Torque Ref. Failure Preset No. 4603

Set a preset torque for when an analog input live zero situation or fieldbus communication warning has been detected, and the response has been selected to use this preset.

P2.2.3.19 Torque Ref. Lowpass Filter Tc No. 2335

Set the time constant of the reference filter. Setting it to 0 disables the filter.

P2.2.3.20 Torque Reference Step No. 4542

Set a torque reference step after ramping and filtering. Can be used to create an offset or an impulse to the torque controller.

7.3.2.4 Power Reference

This group contains parameters for configuring the drive's power reference settings. The following diagram depicts the control chain. The reference settings for the I/O control place are fully displayed in the diagram as an example, however similar selector and combining logics are also available for the other control places as well.

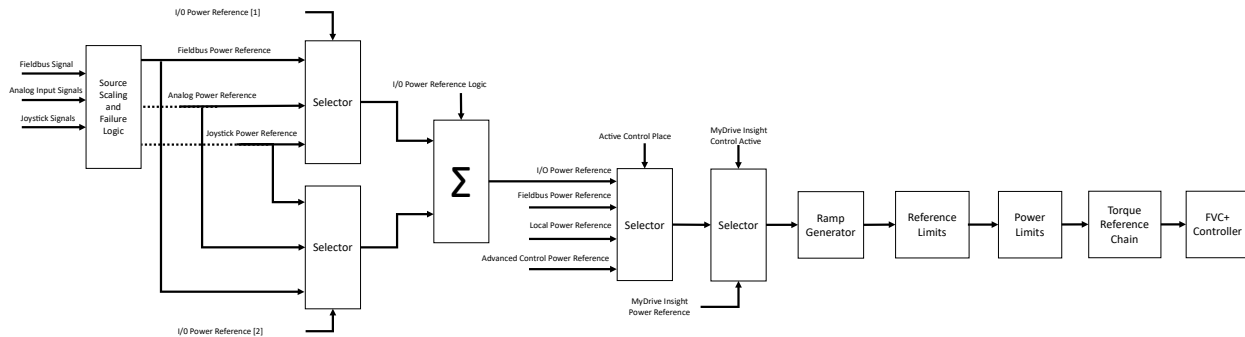

Figure 51: Power Control Chain Diagram

Source Selection:

As an example, to set up the reference for the I/O control place do the following: Use **No. 1930** to select two sources as individual array elements of the parameter. Then using **No. 1920** select a combination logic for these two sources. A single source can be selected as is, or the two can be, for example, summed, divided, or the minimum of them can be selected.

The same settings can be made for other control places with their respective source selection and source logic parameters found within this parameter group.

Signal Scaling:

If one of the analog inputs is selected as the source the respective scaling signals can be used to interpret the input as a speed signal. For analog signals the maximum and minimum of each terminal can be set in **G9**. Set the corresponding maximum and minimum torque values with parameters **No. 4571** and **No. 8027**.

Response to Signal Failure:

In case of a signal failure (Live Zero event for analog signals and Fieldbus Watchdog event for fieldbus signals) the signal is no longer healthy. In this case, the signal respective parameters (**No. 4604-4606**) can be used to select a desirable response. The unhealthy signal can be replaced with a preset value defined with parameter **No. 4607** or the previous value of the signal from 10 seconds before the failure event.

P2.2.4.1 I/O Power Reference Source No. 1930

Select the power reference sources for when the drive operates in I/O control. Two sources are available (Index 0 and Index 1), which can be combined into 1 reference value with parameter **No. 1920**.

No.	Name	Description
0	None	No source is selected. A reference of zero is provided.
2	Fieldbus reference	The reference is obtained from the fieldbus power reference value (No. 4575). Select how to respond if this signal fails with No. 4606 .
3	Reference 1 input	The reference is obtained from the analog power reference 1. Select the analog terminal with No. 4573 . Set the scaling of the signal with No. 4670 and No. 4671 . Select how to respond if this signal fails with No. 4604 .
4	Reference 2 input	The reference is obtained from the analog power reference 2. Select the analog terminal with No. 1924 . Set the scaling of the signal with No. 4672 and No. 4673 . Select how to respond if this signal fails with No. 4605 .
6	Joystick 1	The reference is obtained from the Joystick 1 function. Further configure this signal in G2.2.5 .
7	Joystick 2	The reference is obtained from the Joystick 2 function. Further configure this signal in G2.2.5 .
9	Logic Reference	The reference is obtained from the logic feature. Refer to the <i>MyDrive® Insight Logic Feature Application Guide</i> for configuration information.

P2.2.4.2 I/O Power Reference Logic No. 1920

Select how to form the power reference out of the 2 inputs when operating in I/O control.

No.	Name	Description
0	Source 1	Use the first of the two source inputs
1	Source 2	Use the second of the two source inputs
2	Sum	Source 1 + Source 2
3	Subtract	Source 1 - Source 2
4	Divide	Source 1 / Source 2 Note: When dividing by zero, the reference is set to its maximum.
5	Multiply	Source 1 * Source 2 Note: The reference is saturated at +/- its maximum.
6	Maximum	Use whichever source is greater in value at the time.
7	Minimum	Use whichever source is smaller in value at the time.
8	Toggle	Use an input to toggle between Source 1 and 2 with the respective digital input signal. With low input signal Source 1 is selected, and with high input signal Source 2 is selected.

P2.2.4.3 Fieldbus Power Reference Source No. 1931

Select the power reference sources for when the drive operates in fieldbus control. Two sources are available (Index 0 and Index 1), which can be combined into 1 reference value with parameter **No. 1921**. Selections are the same as for I/O Power Reference.

P2.2.4.4 Fieldbus Power Reference Logic No. 1921

Select how to form the power reference out of the 2 inputs when operating in fieldbus control. Selections are the same as for I/O Power Reference Logic.

P2.2.4.5 Adv. Power Reference Source No. 1932

Select the power reference sources for when the drive operates in advanced control. Two sources are available (Index 0 and Index 1), which can be combined into 1 reference value with parameter **No. 1922**. Selections are the same as for I/O Power Reference.

P2.2.4.6 Adv. Power Reference Logic No. 1922

Select how to form the power reference out of the 2 inputs when operating in advanced control. Selections are the same as for I/O Power Reference Logic.

P2.2.4.7 Local Power Reference Source No. 1926

Select the power reference source for when the drive operates in local control.

No.	Name	Description
1	Local Reference	The reference given with the control panel is used. Also, parameter No. 4574 can be used to give the reference.
2	Fieldbus reference	The reference is obtained from the fieldbus power reference value (No. 4575). Select how to respond if this signal fails with No. 4606 .
3	Reference 1 input	The reference is obtained from the analog torque reference 1. Select the analog terminal with No. 4573 . Set the scaling of the signal with No. 4670 and No. 4671 . Select how to respond if this signal fails with No. 4604 .
4	Reference 2 input	The reference is obtained from the analog torque reference 2. Select the analog terminal with No. 1924 . Set the scaling of the signal with No. 4672 and No. 4673 . Select how to respond if this signal fails with No. 4605 .
6	Joystick 1	The reference is obtained from the Joystick 1 function. Further configure this signal in G2.2.5 .
7	Joystick 2	The reference is obtained from the Joystick 2 function. Further configure this signal in G2.2.5 .
9	Logic Reference	The reference is obtained from the logic feature. Refer to the <i>MyDrive® Insight Logic Feature Application Guide</i> for configuration information.

P2.2.4.8 Power Reference 1 Input**No. 4573**

Select the input terminal for power reference 1.

No.	Name	Description
0	None	No input is selected and a value of 0% is applied to the associated function.
5	50 %	A virtual value of 50 % is applied to the associated function.
10	100 %	A virtual value of 100 % is applied to the associated function.
*	Available analog input terminals	A dynamically generated selection of available analog input terminals is presented as an option. The specific set depends on the type and number of I/O options installed in the system.

P2.2.4.9 Power Reference 1 Max**No. 4670**

Set the power reference 1 maximum in % of motor nominal power. The set power corresponds to input 1 maximum voltage/current.

P2.2.4.10 Power Reference 1 Min**No. 4671**

Set the power reference 1 minimum in % of motor nominal power. The set power corresponds to input 1 minimum voltage/current.

P2.2.4.11 Power Reference 2 Input**No. 1924**

Select the input terminal for power reference 2.

No.	Name	Description
0	None	No input is selected and a value of 0% is applied to the associated function.
5	50 %	A virtual value of 50 % is applied to the associated function.
10	100 %	A virtual value of 100 % is applied to the associated function.
*	Available analog input terminals	A dynamically generated selection of available analog input terminals is presented as an option. The specific set depends on the type and number of I/O options installed in the system.

P2.2.4.12 Power Reference 2 Max**No. 4672**

Set the power reference 2 maximum in % of motor nominal power. The set power corresponds to input 2 maximum voltage/current.

P2.2.4.13 Power Reference 2 Min**No. 4673**

Set the power reference 2 minimum in % of motor nominal power. The set power corresponds to input 2 minimum voltage/current.

P2.2.4.14 Power Ref. 1 Input Failure Response No. 4604

Set the response to a live zero situation for power reference 1 input. This will affect if the value of the selected terminal goes below its Live Zero Threshold.

No.	Name	Description
0	No response	The reference will be taken from the input terminal regardless of the failure.
1	Preset	The preset reference set with parameter No. 4607 is used.
2	Previous	The reference seen 10 seconds before the failure event is used.

P2.2.4.15 Power Ref. 2 Input Failure Response No. 4605

Set the response to a live zero situation for power reference 2 input. This will affect if the value of the selected terminal goes below its Live Zero Threshold.

No.	Name	Description
0	No response	The reference will be taken from the input terminal regardless of the failure.
1	Preset	The preset reference set with parameter No. 4607 is used.
2	Previous	The reference seen 10 seconds before the failure event is used.

P2.2.4.16 Power Ref. Fieldbus Failure Response No. 4606

Set the response to a fieldbus communication error (fieldbus fault, process data timeout or fieldbus watchdog) for fieldbus power reference. This will affect if one of the fieldbus communication errors is detected and the response for the error is set to warning.

No.	Name	Description
0	No response	The reference will be taken from the fieldbus regardless of the failure.
1	Preset	The preset reference set with parameter No. 4607 is used.
2	Previous	The reference seen 10 seconds before the failure event is used.

P2.2.4.17 Power Ref. Failure Preset No. 4607

Set a preset power for when an analog input live zero situation or fieldbus communication warning has been detected, and the response has been selected to use this preset.

P2.2.4.18 Control Panel Power Reference No. 4574

Shows the value of the power reference given from the control panel.

7.3.2.5 Joystick

The Joystick-feature can be used to provide an analog input -based speed, torque, or power reference. It comes with deadband and sleep functionalities, which can be used separately or in unison.

The deadband function is used to ignore small changes in the input reference around the zero-reference point. Similarly, the sleep functionality can be used to set an input window, in which the drive stops running. The sleep functionality is available only for the speed control mode.

The drive features two separate joystick functions: Joystick 1 and Joystick 2. These joysticks are configured in this group and selected as the reference source with the respective source selection parameters for each reference chain.

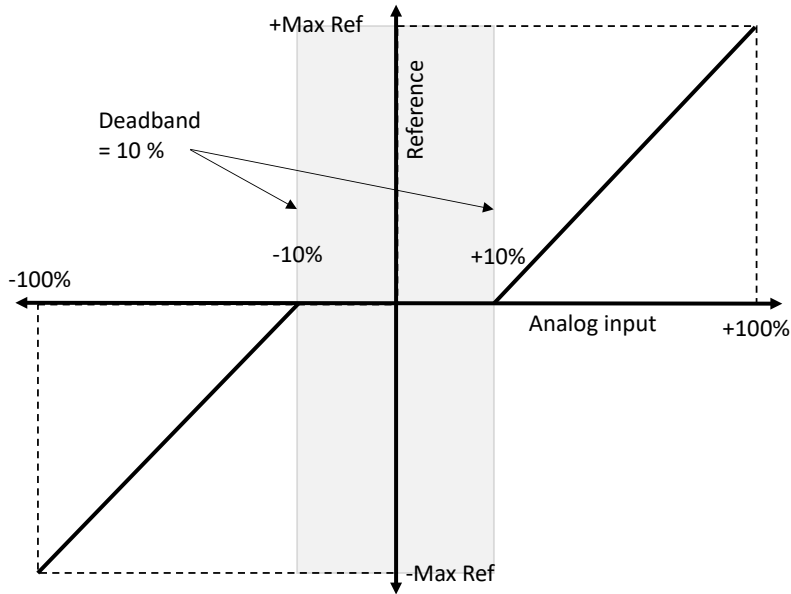

Figure 52: Deadband function of the Joystick control.

Both joysticks are scaled based on the following variables:

Input	Speed Reference [Hz]	Torque Reference [%]	Power Reference [%]
AI min. [V/mA]	(Motor Nominal Frequency * Joystick 1/2 Min)/100	Joystick 1/2 Min.	Joystick 1/2 Min.
AI max. [V/mA]	(Motor Nominal Frequency * Joystick 1/2 Max)/100	Joystick 1/2 Max.	Joystick 1/2 Max.

P2.2.5.1 Joystick 1 Input No. 4500

Select the analog input terminal for the Joystick 1.

No.	Name	Description
0	None	No input is selected and a value of 0% is applied to the associated function.
5	50 %	A virtual value of 50 % is applied to the associated function.
10	100 %	A virtual value of 100 % is applied to the associated function.
*	Available analog input terminals	A dynamically generated selection of available analog input terminals is presented as an option. The specific set depends on the type and number of I/O options installed in the system.

P2.2.5.2 Joystick 1 Max No. 4614

Set the maximum value of the joystick 1 output in percent of motor nominal speed, torque or power depending on the reference chain joystick 1 is used in.

P2.2.5.3 Joystick 1 Min No. 4615

Set the minimum value of the joystick 1 output in percent of motor nominal speed, torque or power depending on the reference chain joystick 1 is used in.

P2.2.5.4 Joystick 1 Deadband No. 4503

Set the deadband for Joystick 1 in % of the outgoing signals Max-Min range. The joystick output will be forced to zero, when the input is within the deadband.

P2.2.5.5 Joystick 1 Sleep Window No. 4550

Set the sleep limit for Joystick 1 in % of the outgoing signals Max-Min range. Drive will stop running when the joystick output within the sleep zone for the set sleep delay. Note: Sleep limit can only be applied when using the joystick with the speed controller.

P2.2.5.6 Joystick 1 Sleep Delay No. 4552

Set a delay for the Joystick 1 sleep-function.

P2.2.5.7 Joystick 1 Input Failure Response No. 4608

Set the response to a live zero event for joystick 1 input. This will affect if the value of the selected terminal goes below its Live Zero Threshold.

No.	Name	Description
0	No response	The reference will be taken from the joystick regardless of the failure.
1	Preset	The preset reference set with parameter No. 4610 is used.
2	Previous	The reference seen 10 seconds before the failure event is used.

P2.2.5.8 Joystick 1 Failure Preset No. 4610

Set a preset in % of the controlled reference Max-Min range for Joystick 1. The preset is used if a live zero situation has been detected for the selected terminal and the response has been selected to use this preset. The following are the conversion formulas for different controlled references.

Speed preset [Hz]:

Speed preset [Hz] = 0.01 * Joystick 1 Failure Preset * (Output Max - Output Min) + Output Min, where
 Output Max = (Motor Nominal Frequency * Joystick 1 Max)/100
 Output Min = (Motor Nominal Frequency * Joystick 1 Min)/100

Torque preset [%]:

Torque preset [%] = 0.01 * Joystick 1 Failure Preset * (Joystick 1 Max – Joystick 1 Min) + Joystick 1 Min

Power preset [%]:

Power preset [%] = 0.01 * Joystick 1 Failure Preset * (Joystick 1 Max – Joystick 1 Min) + Joystick 1 Min

P2.2.5.9 Joystick 2 Input No. 4504

Select the analog input terminal for the Joystick 2.

No.	Name	Description
0	None	No input is selected and a value of 0% is applied to the associated function.
5	50 %	A virtual value of 50 % is applied to the associated function.

No.	Name	Description
10	100 %	A virtual value of 100 % is applied to the associated function.
*	Available analog input terminals	A dynamically generated selection of available analog input terminals is presented as an option. The specific set depends on the type and number of I/O options installed in the system.

P2.2.5.10 Joystick 2 Max No. 4616

Set the maximum value of the joystick 2 output in percent of motor nominal speed, torque or power depending on the reference chain joystick 2 is used in.

P2.2.5.11 Joystick 2 Min No. 4617

Set the minimum value of the joystick 2 output in percent of motor nominal speed, torque or power depending on the reference chain joystick 2 is used in.

P2.2.5.12 Joystick 2 Deadband No. 4507

Set the deadband for Joystick 2 in % of the outgoing signals Max-Min range. The joystick output will be forced to zero, when the input is within the deadband.

P2.2.5.13 Joystick 2 Sleep Window No. 4551

Set the sleep limit for Joystick 2 in % of the outgoing signals Max-Min range. Drive will stop running when the joystick output within the sleep zone. Note: Sleep limit can only be applied when using the joystick with the speed controller.

P2.2.5.14 Joystick 2 Sleep Delay No. 4553

Set a delay for the Joystick 2 sleep-function.

P2.2.5.15 Joystick 2 Input Failure Response No. 4609

Set the response to a live zero event for joystick 1 input. This will affect if the value of the selected terminal goes below its Live Zero Threshold.

No.	Name	Description
0	No response	The reference will be taken from the joystick regardless of the failure.
1	Preset	The preset reference set with parameter No. 4611 is used.
2	Previous	The reference seen 10 seconds before the failure event is used.

P2.2.5.16 Joystick 2 Failure Preset No. 4611

Set a preset in % of the controlled reference Max-Min range for Joystick 2. The preset is used if a live zero situation has been detected for the selected terminal and the response has been selected to use this preset. The following are the conversion formulas for different controlled references.

Speed preset [Hz]:

Speed preset [Hz] = 0.01 * Joystick 2 Failure Preset * (Output Max - Output Min) + Output Min, where
 Output Max = (Motor Nominal Frequency * Joystick 2 Max)/100
 Output Min = (Motor Nominal Frequency * Joystick 2 Min)/100

Torque preset [%]:

Torque preset [%] = 0.01 * Joystick 2 Failure Preset * (Joystick 2 Max – Joystick 2 Min) + Joystick 2 Min

Power preset [%]:

Power preset [%] = 0.01 * Joystick 2 Failure Preset * (Joystick 2 Max – Joystick 2 Min) + Joystick 2 Min

7.3.3 Limits

This group contains parameters for configuring different limits for the drive.

7.3.3.1 Speed Limits

The speed of the motor can be limited by defining minimum (**No. 1722**) and maximum (**No. 1729**) allowed motor speeds. The maximum allowed speed can also be set separately for the reversing direction (negative speed) with **No. 1728**.

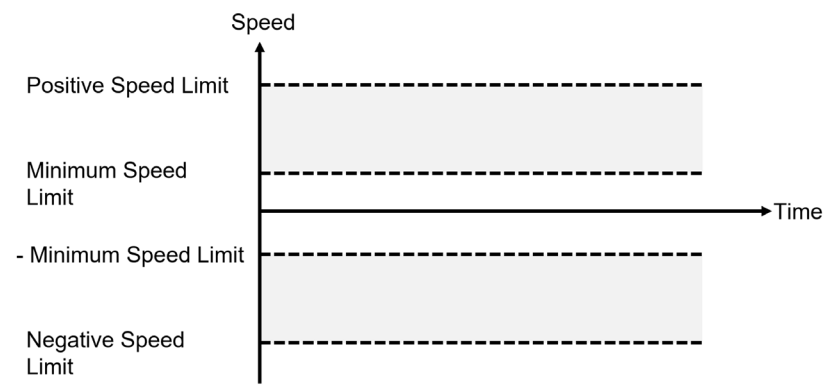

Figure 53: Definition of motor speed limits.

Additionally, two interchangeable positive (**No. 3210, No. 3211**) and negative (**No. 3213, No. 3214**) speed reference limits can be set. With the associated digital input signals, the active limits can be selected. With low input signals the first limits are used and with high signals the second limits are used. Select the terminals for these inputs with parameters **No. 3212** and **No. 3215**.

When operating in torque or power control modes, the speed is not controlled directly, but these limits can affect the motor speed by means defined with the Speed Limit in Torque Control parameter **No. 2332**. Depending on the torque demand and the loading conditions, the drive may reach speed limits. This parameter selects how these limits are defined. When a speed limit is reached, the speed controller takes active control of the drive, until the speed is no longer limited due to changes in torque demand or loading.

P2.3.1.1 Positive Speed Limit No. 1729

Set the speed limit for positive direction.

P2.3.1.2 Negative Speed Limit No. 1728

Set the speed limit for negative direction.

P2.3.1.3 Minimum Speed Limit No. 1722

Set the minimum speed for positive and negative direction.

P2.3.1.4 Positive Speed Ref. Limit 1 No. 3210

Set a limit for the speed reference in the positive rotation direction. This limit is used when the Positive Speed Ref. Limit Sel Input is inactive.

P2.3.1.5 Positive Speed Ref. Limit 2 No. 3211

Set another limit for the speed reference in the positive rotation direction. This limit is used when the Positive Speed Ref. Limit Sel Input signal is active.

P2.3.1.6 Positive Speed Ref. Limit Sel Input No. 3212

Select an input for the selection between limit 1 and 2 for the positive rotation direction. Limit 1 is selected when this signal is inactive and limit 2 is selected when this signal is active.

No.	Name	Description
0	None (False)	No input is selected. A virtual value of FALSE is applied.
1	None (True)	No input is selected. A virtual value of TRUE is applied.
*	Fieldbus control word 1/2 digital input bits	Fieldbus CTW1 digital input bits 12-15 and CTW2 digital input bits 0-15 will be presented as options.
*	Logic Digital I/O virtual terminals	Virtual digital outputs from the Logic Feature function blocks are presented as input options.
*	Available digital input terminals	A dynamically generated selection of available digital input terminals is presented as an option. The specific set depends on the type and number of I/O options installed in the system.

P2.3.1.7 Negative Speed Ref. Limit 1 No. 3213

Set a limit for the speed reference in the negative rotation direction. This limit is used when the Negative Speed Ref. Limit Sel Input is inactive.

P2.3.1.8 Negative Speed Ref. Limit 2 No. 3214

Set another limit for the speed reference in the negative rotation direction. This limit is used when the Negative Speed Ref. Limit Sel Input is active.

P2.3.1.9 Negative Speed Ref. Limit Sel Input No. 3215

Select an input for the selection of the speed reference limit in the negative rotation direction. Limit 1 is selected when the signal is inactive and limit 2 is selected when the signal is active.

No.	Name	Description
0	None (False)	No input is selected. A virtual value of FALSE is applied.
1	None (True)	No input is selected. A virtual value of TRUE is applied.
*	Fieldbus control word 1/2 digital input bits	Fieldbus CTW1 digital input bits 12-15 and CTW2 digital input bits 0-15 will be presented as options.
*	Logic Digital I/O virtual terminals	Virtual digital outputs from the Logic Feature function blocks are presented as input options.
*	Available digital input terminals	A dynamically generated selection of available digital input terminals is presented as an option. The specific set depends on the type and number of I/O options installed in the system.

P2.3.1.10 Speed Limit Mode Torque Control No. 2332

Select the speed limiting mode during torque control. Options are described in following table and figures.

No.	Name	Description
0	Pos./Neg. Speed Limit	The speed is limited between the negative and positive speed limits. Limits defined by No. 1728 and No. 1729 .
1	Limited by Ramp	The speed is limited by the absolute speed reference after ramping. The reference itself is limited by the positive and negative speed limits. Limits defined by No. 1728 and No. 1729 .
2	Window	A window is set around the ramped speed reference. Setup the window size with parameters No. 2333 and No. 2334 .
3	Neg. Limit to Ramp	The speed is limited between the negative speed limit and the speed reference after ramping. Limit defined with No. 1728 .
4	Ramp to Max. Limit	The speed is limited between the speed reference after ramping and the positive speed limit. Limit defined with No. 1729 .

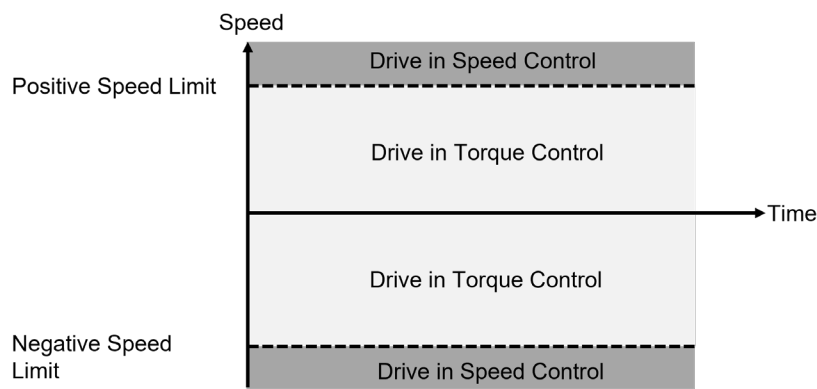

Figure 54: Pos./Neg. Speed Limit.

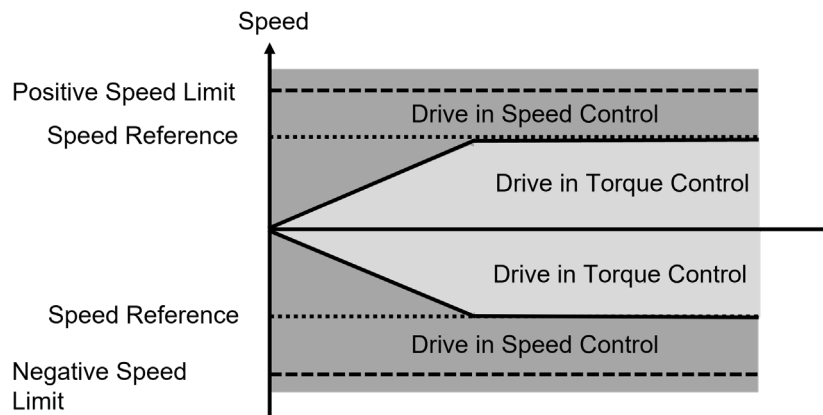

Figure 55: Limited By Ramp.

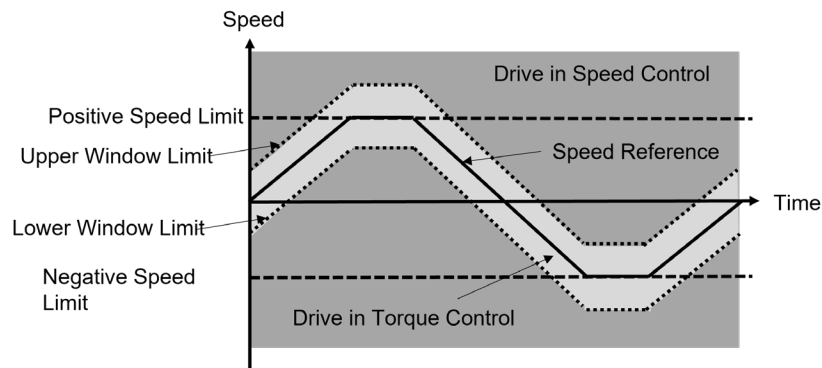

Figure 56: Window.

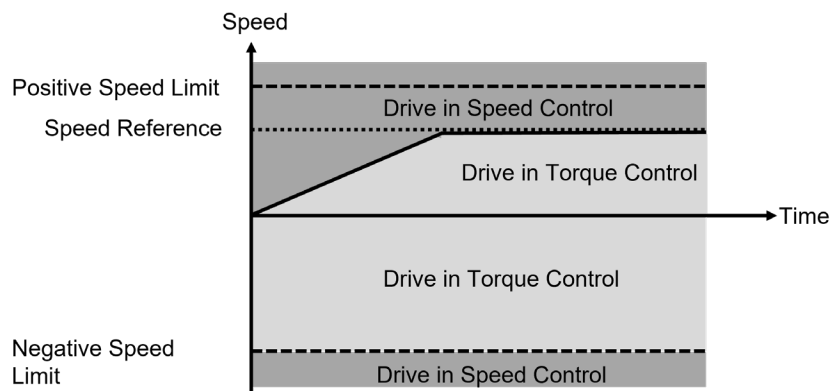

Figure 57: Neg. Limit to Ramp.

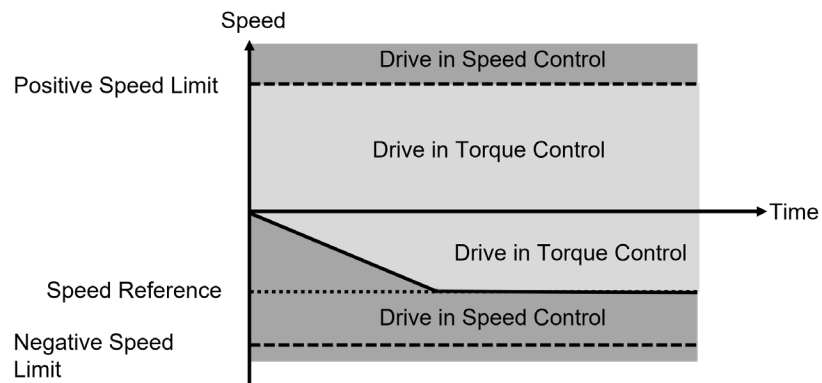

Figure 58: Ramp to Pos. Limit.

P2.3.1.11 Lower Window Limit No. 2333
Set the window size towards the positive speed direction.

P2.3.1.12 Upper Window Limit No. 2334
Set the window size towards the negative speed direction.

7.3.3.2 Output Current Limit

The application offers tools for limiting the drive's output current (motor stator current).

A current limit controller will activate if the output current exceeds the current limit. With the U/f and VVC+ motor control principles the current is not directly controlled, however, if the limit controller is activated it will bring the current back to the level of the limit. With the FVC+ control principle, the current is directly controlled. With this principle the motor current limit can be used as the upper limit for the current controller's reference.

The limit itself can be set with parameter **No. 3190**. If desired, parameter **No. 3191** can be used to choose to further adjust the signal by scaling it with either an analog input signal, or a fieldbus signal (**No. 3192**). The terminal for the analog input signal can be selected with **No. 3199**. If either of these signals are used, a response can be selected with **No. 5169** in case the signal fails due to a Live Zero or Fieldbus Watchdog event. Internal protection features may momentarily override the set current limit.

The motor current limit operation principle is further explained in the following figure for forward direction and motoring operation. When the measured motor current is lower than the motor current limit the PID controller error (e) is positive, and the internal positive torque limit is at the set level. When the load of the drive suddenly increases, it causes the motor current to exceed the motor current limit. This makes the PID controller error negative, which decreases the internal positive torque limit to reduce the motor torque as well as the current. Consequently, the speed of the motor will decrease because the drive cannot fully respond to the load torque demand. When the load torque again decreases the drive recovers from current limit control and the speed returns to its initial value.

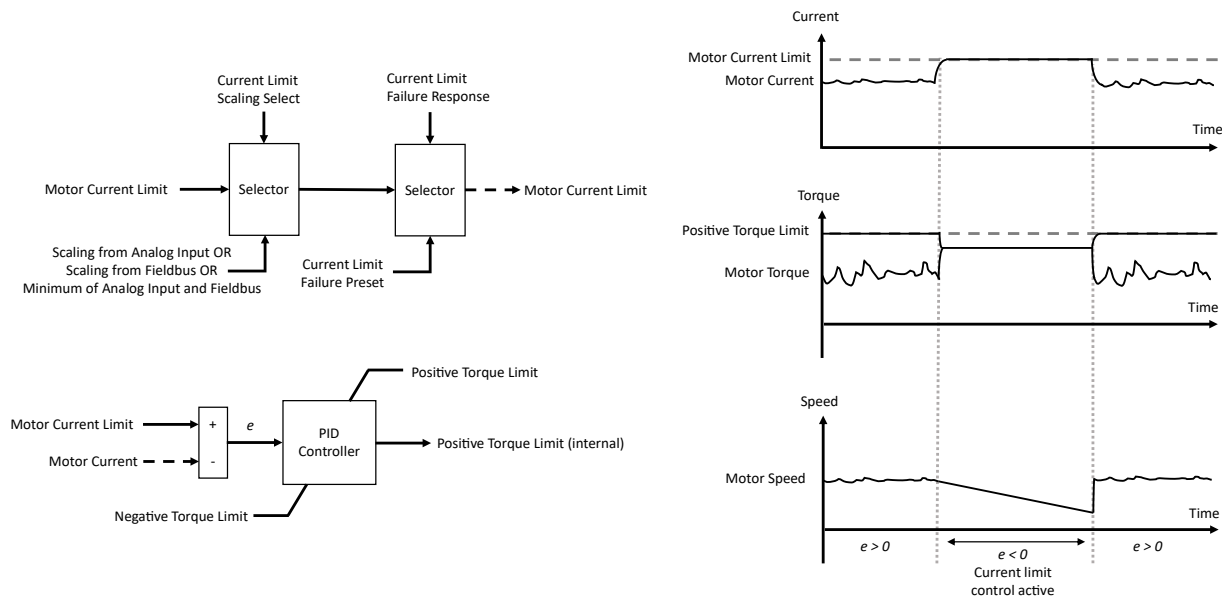

Figure 59: Operation principle of output current limit controller during sudden load increase.

P2.3.2.1 Motor Current Limit No. 3190

Set the motor current limit in % of the nominal motor current.

P2.3.2.2 Current Limiter Kp No. 3193

Set the proportional gain of the current limit controller.

P2.3.2.3 Current Limiter Ti No. 3194

Set the integration time of the current limit controller. The value is scaled to % of the nominal setting.

P2.3.2.4 Current Limit Scaling Select **No. 3191**

Select the source of scaling the current limit value. The scaling is applied as a multiplier to the Motor Current Limit parameter value.

No.	Name	Description
0	No Scaling	No scaling is applied.
1	Analog Input	Scaling is applied from analog input. Use parameter No. 3199 to select the terminal.
2	Fieldbus	Scaling is applied from fieldbus with parameter No. 3192 .
3	Minimum of Analog Input and Fieldbus	The smaller value between analog input and fieldbus is applied for scaling.

P2.3.2.5 Current Limit Scaling Input **No. 3199**

Select the analog input terminal to be used when using an analog input to scale the current limit.

No.	Name	Description
0	None	No input is selected and a value of 0% is applied to the associated function.
5	50 %	A virtual value of 50 % is applied to the associated function.
10	100 %	A virtual value of 100 % is applied to the associated function.
*	Available analog input terminals	A dynamically generated selection of available analog input terminals is presented as an option. The specific set depends on the type and number of I/O options installed in the system.

P2.3.2.6 Current Limit Failure Response **No. 5169**

Set the response to a live zero or fieldbus communication error (fieldbus fault, process data timeout or fieldbus watchdog) for the current limit. This will affect if an analog input is used to scale the limit and the value of the selected terminal goes below its Live Zero Threshold. Or if fieldbus is used to scale the limit, one of the fieldbus communication errors is detected, and the response for the fieldbus error is set to warning.

No.	Name	Description
0	No response	The limit will be taken from the given input regardless of the failure.
1	Preset	The preset limit set with parameter No. 5170 is used.

P2.3.2.7 Current Limit Failure Preset **No. 5170**

Set the preset value which is applied when the scaling signal experiences errors.

7.3.3.3 Torque Limits

The application offers a variety of functions to control both motoring and regenerative side torque limits, as presented in the torque limit chain diagram in the following figure.

Primary limits can be set with **No. 3156** and **No. 3160**, which can then be scaled with analog inputs (**No. 3197**, **No. 3198**) or fieldbus signals (**No. 3157**, **No. 3161**). If the scaling signal fails due to Live Zero event or Fieldbus Watchdog event, failure responses can be configured with **No. 5171** and **No. 5233**. Presets (**No. 3158**, **No. 3163**) can be applied with digital input signals (**No. 3150**, **No. 3162**) as a bypass to the primary limits and their scaling.

At the end of the torque limit chain there are both a Positive Torque Limit and a Negative Torque Limit which are defined with **No. 1810** and **No. 1811**. In addition, the power limits (after conversion to torque) will affect the final torque limits fed to the motor controller, as presented in the final selection section of the chain diagram. The torque limits apply regardless of the drive Control Mode.

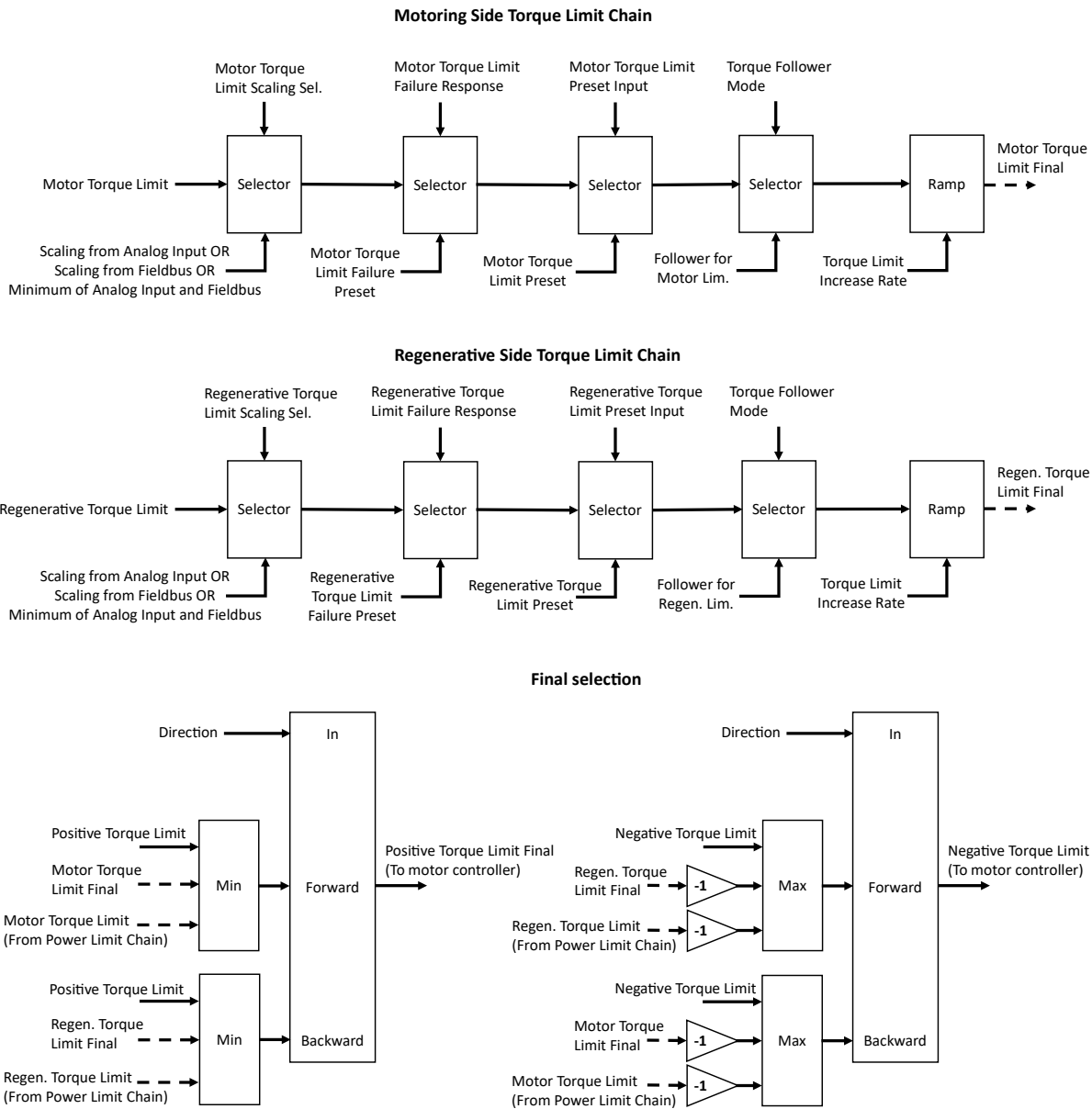

Figure 60: Torque limit chain diagram for motoring and regenerating sides.

The drive's operating range is divided into four quadrants, two motoring and two regenerating as presented in the following figure. The drive operates in one of these quadrants depending on the sign of the torque demand in combination of the motor's rotation direction. The drive uses always the tighter of the two quadrant-wise limits.

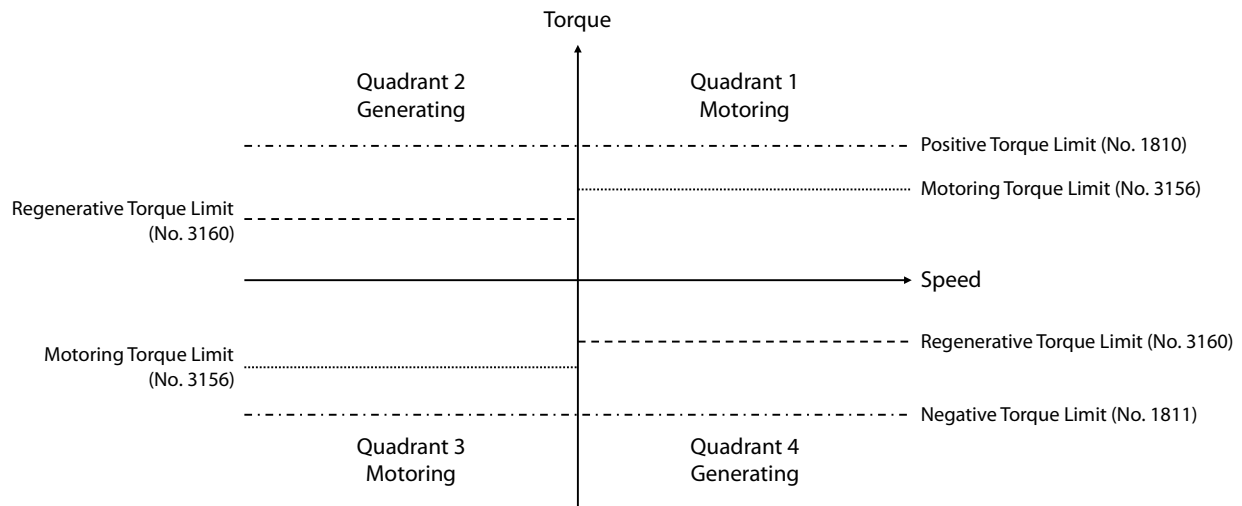

Figure 61: Definition of torque limits.

The torque limit chain also includes a torque follower functionality which can be configured separately for both limits with **No. 3154**. With the follower the limits can match the actual torque with a configurable amount of hysteresis **No. 3152**. However, the increase rate of the limit will regulate sudden torque spikes and ensure smooth and steady operation.

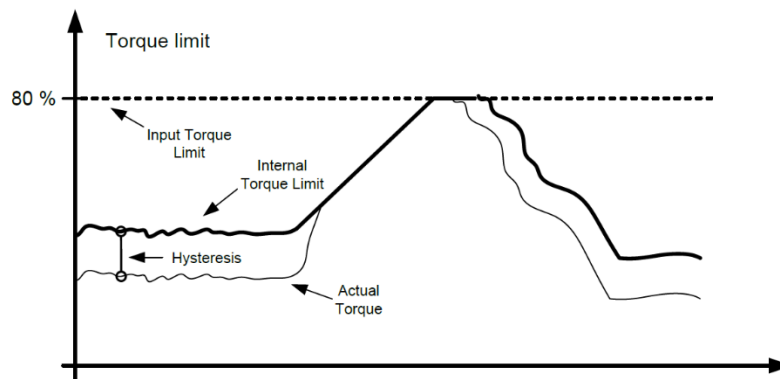

Figure 62: Torque Follower operation principle.

P2.3.3.1 Positive Torque Limit No. 1810

Set the positive torque limit (quadrants 1 and 2) in % of nominal motor torque.

P2.3.3.2 Negative Torque Limit No. 1811

Set the negative torque limit (quadrants 3 and 4) in % of nominal motor torque.

P2.3.3.3 Motor Torque Limit No. 3156

Set the motor torque limit in % of motor nominal torque. This is the limit value which is selected by default when no scaling or presets are used.

P2.3.3.4 Motor Torque Limit Scaling Sel. No. 3151

Select the source for scaling the motor torque limit. This scaling is applied as a multiplier to the Motor Torque Limit parameter value.

No.	Name	Description
0	No Scaling	No scaling is applied.
1	Analog Input	Scaling is applied from analog input. Use parameter No. 3197 to select the terminal.
2	Fieldbus	Scaling is applied from fieldbus with parameter No. 3157 .
3	Minimum of Analog Input and Fieldbus	The smaller value between analog input and fieldbus is applied for scaling.

P2.3.3.5 Motor Torque Limit Scaling Input No. 3197

Select an input terminal for scaling the motor power limit if analog input scaling is selected.

No.	Name	Description
0	None	No input is selected and a value of 0% is applied to the associated function.
5	50 %	A virtual value of 50 % is applied to the associated function.
10	100 %	A virtual value of 100 % is applied to the associated function.
*	Available analog input terminals	A dynamically generated selection of available analog input terminals is presented as an option. The specific set depends on the type and number of I/O options installed in the system.

P2.3.3.6 Motor Torque Limit Preset No. 3158

Set a preset for the motor torque limit in % of motor nominal torque. Enable this preset by activating the respective digital input.

P2.3.3.7 Motor Torque Limit Preset Input No. 3150

Select an input which is used to enable the motor torque limit preset.

No.	Name	Description
0	None (False)	No input is selected. A virtual value of FALSE is applied.
1	None (True)	No input is selected. A virtual value of TRUE is applied.
*	Fieldbus control word 1/2 digital input bits	Fieldbus CTW1 digital input bits 12-15 and CTW2 digital input bits 0-15 will be presented as options.
*	Logic Digital I/O virtual terminals	Virtual digital outputs from the Logic Feature function blocks are presented as input options.
*	Available digital input terminals	A dynamically generated selection of available digital input terminals is presented as an option. The specific set depends on the type and number of I/O options installed in the system.

P2.3.3.8 Regenerative Torque Limit No. 3160

Set the regenerative torque limit in % of motor nominal torque. This is the limit value which is selected by default when no scaling or presets are used.

P2.3.3.9 Regenerative Torque Limit Scaling Sel.**No. 3159**

Select the source for scaling the regenerative torque limit. This scaling is applied as a multiplier to the Regenerative Torque Limit parameter value.

No.	Name	Description
0	No Scaling	No scaling is applied.
1	Analog Input	Scaling is applied from analog input. Use parameter No. 3197 to select the terminal.
2	Fieldbus	Scaling is applied from fieldbus with parameter No. 3157 .
3	Minimum of Analog Input and Fieldbus	The smaller value between analog input and fieldbus is applied for scaling.

P2.3.3.10 Regenerative Torque Limit Scaling Input**No. 3198**

Select an input for scaling the regenerative power limit if analog input scaling is selected.

No.	Name	Description
0	None	No input is selected and a value of 0% is applied to the associated function.
5	50 %	A virtual value of 50 % is applied to the associated function.
10	100 %	A virtual value of 100 % is applied to the associated function.
*	Available analog input terminals	A dynamically generated selection of available analog input terminals is presented as an option. The specific set depends on the type and number of I/O options installed in the system.

P2.3.3.11 Regenerative Torque Limit Preset**No. 3163**

Set a preset for the regenerative torque limit in % of motor nominal torque. Enable this preset by activating the respective digital input.

P2.3.3.12 Regenerative Torque Limit Preset Input**No. 3162**

Select an input which is used to enable the regenerative torque limit preset.

No.	Name	Description
0	None (False)	No input is selected. A virtual value of FALSE is applied.
1	None (True)	No input is selected. A virtual value of TRUE is applied.
*	Fieldbus control word 1/2 digital input bits	Fieldbus CTW1 digital input bits 12-15 and CTW2 digital input bits 0-15 will be presented as options.
*	Logic Digital I/O virtual terminals	Virtual digital outputs from the Logic Feature function blocks are presented as input options.
*	Available digital input terminals	A dynamically generated selection of available digital input terminals is presented as an option. The specific set depends on the type and number of I/O options installed in the system.

P2.3.3.13 Torque Follower Mode No. 3154

Select the torque follower configuration which allows the torque limit to follow the actual torque.

No.	Name	Description
0	Not Used	Torque follower is disabled.
1	Follower for Motor Lim.	Torque follower is enabled for the motoring torque limit.
2	Follower for Regen. Lim.	Torque follower is enabled for the regenerative torque limit.
3	Follower for both Lims.	Torque follower is enabled for motoring and regenerative torque limits.

P2.3.3.14 Torque Follower Hysteresis No. 3152

Set a hysteresis value for the torque follower in % of motor nominal torque.

P2.3.3.15 Motor Torque Limit Failure Response No. 5171

Set the response to a live zero or fieldbus communication error (fieldbus fault, process data timeout or fieldbus watchdog) for the motoring torque limit. This will affect if an analog input is used to scale the limit and the value of the selected terminal goes below its Live Zero Threshold. Or if fieldbus is used to scale the limit, one of the fieldbus communication errors is detected, and the response for the fieldbus error is set to warning.

No.	Name	Description
0	No response	The limit will be taken from the given input regardless of the failure.
1	Preset	The preset limit set with parameter No. 5172 is used.

P2.3.3.16 Motor Torque Limit Failure Preset No. 5172

Set the value of the preset applied when the scaling signal experiences errors.

P2.3.3.17 Regen. Torque Limit Failure Response No. 5233

Set the response to a live zero or fieldbus communication error (fieldbus fault, process data timeout or fieldbus watchdog) for the regenerative torque limit. This will affect if an analog input is used to scale the limit and the value of the selected terminal goes below its Live Zero Threshold. Or if fieldbus is used to scale the limit, one of the fieldbus communication errors is detected, and the response for the fieldbus error is set to warning.

No.	Name	Description
0	No response	The limit will be taken from the given input regardless of the failure.
1	Preset	The preset limit set with parameter No. 5234 is used.

P2.3.3.18 Regen. Torque Limit Failure Preset No. 5234

Set the value of the preset applied when the scaling signal experiences errors.

P2.3.3.19 Positive Torque Ref. Limit No. 4630

Set the positive torque reference limit in % of motor nominal torque. This limit is applied before the torque reference ramp function.

P2.3.3.20 Negative Torque Ref. Limit No. 4631

Set the negative torque reference limit in % of motor nominal torque. This limit is applied before the torque reference ramp function.

7.3.3.4 Power Limits

The application offers a variety of functions to control the power limits. All options are separately available for both the motoring and regenerating operations. The power limit chain diagram is presented in the following figure.

Primary limits can be set with **No. 3167** and **No. 3166**, which can then be scaled with an analog input (**No. 3195**, **No. 3196**) or fieldbus signals (**No. 3175**, **No. 3176**). If the scaling signals somehow fail, failure responses can be configured with **No. 5173** and **No. 5168**.

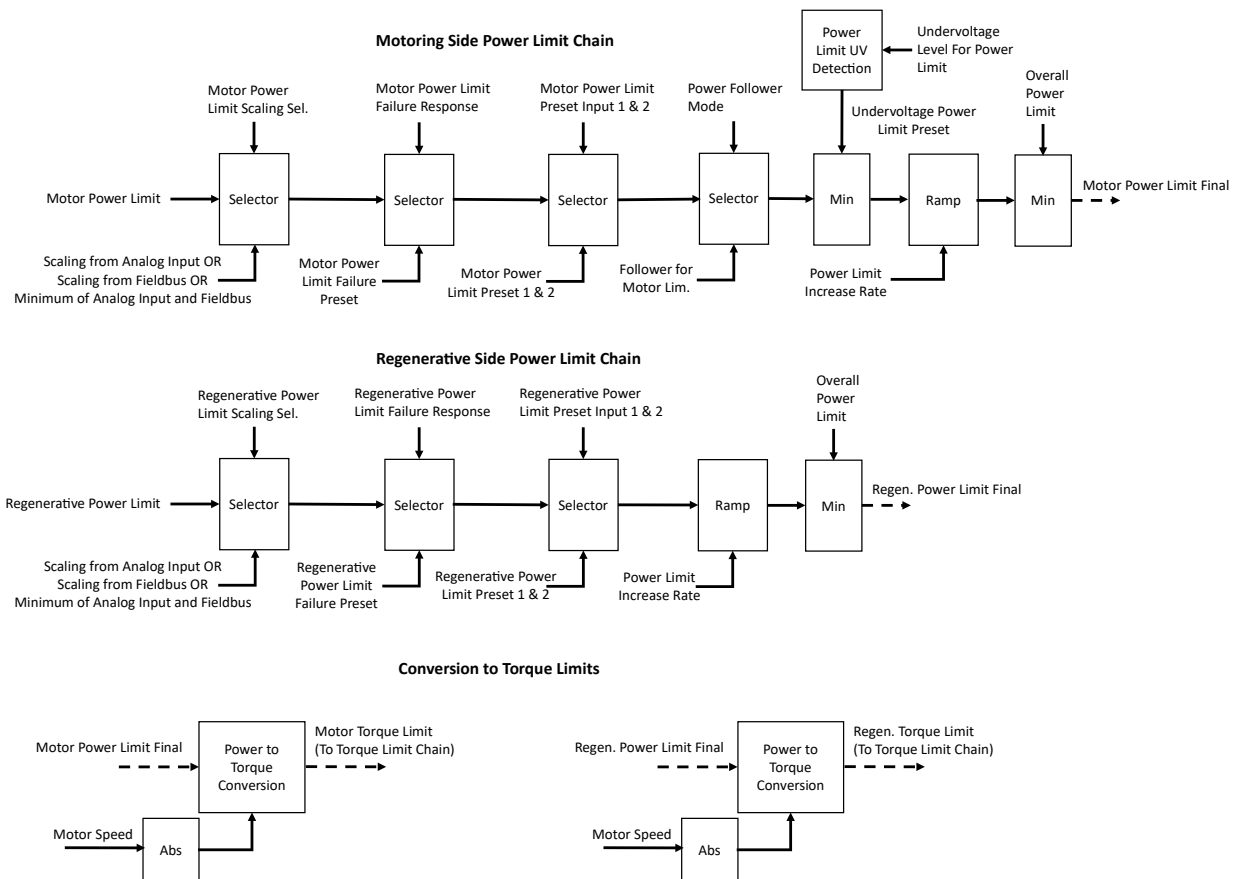

Figure 63: Power limit chain diagram for motoring and regenerating sides.

Two presets can be defined with parameters and toggled between them with binary coded digital input signals accordingly to the following table. If active, the preset will be applied as a bypass for the primary limit and it's possible scaling.

	Preset Input 1 State (No. 3179, No. 3180)	Preset Input 2 State (No. 3181, 3182)
No preset active	OFF	OFF
Preset 1 active	ON	OFF

	Preset Input 1 State (No. 3179, No. 3180)	Preset Input 2 State (No. 3181, 3182)
(No. 3170, 3168)		
Preset 2 active (No. 3171, 3169)	OFF	ON
Limit set to 0 %	ON	ON

A power follower can also be configured for the motoring limit with **No. 3173**. With the follower the limit can match the actual power with a configurable amount of hysteresis (**No. 3174**). However, the increase rate of the limit will regulate sudden power spikes and ensure smooth and steady operation. The power follower will apply as a bypass to all previously mentioned power limit sources.

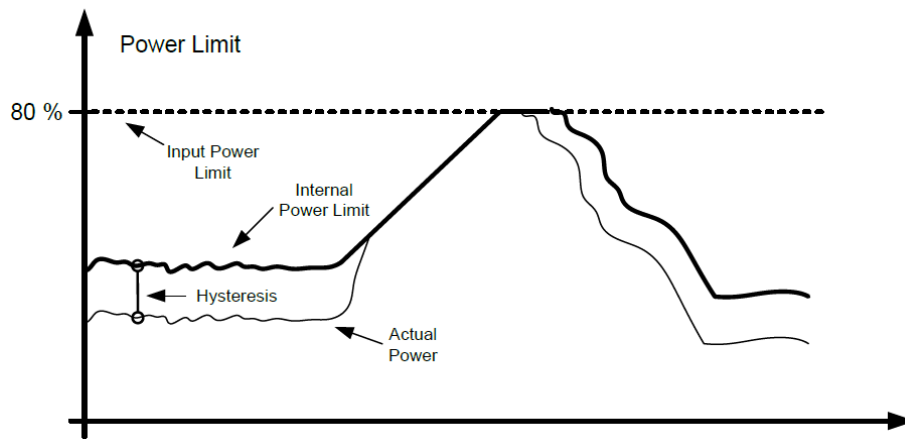

Figure 64: Power follower operation principle.

Motor power can also be limited to a specific DC undervoltage preset value (**No. 3178**) when the DC-link voltage is reduced below a set threshold (**No. 3177**). When the DC-link voltage goes back above this threshold, the DC-undervoltage preset is deactivated. This preset applies as a bypass if its value is smaller than any other power limit function.

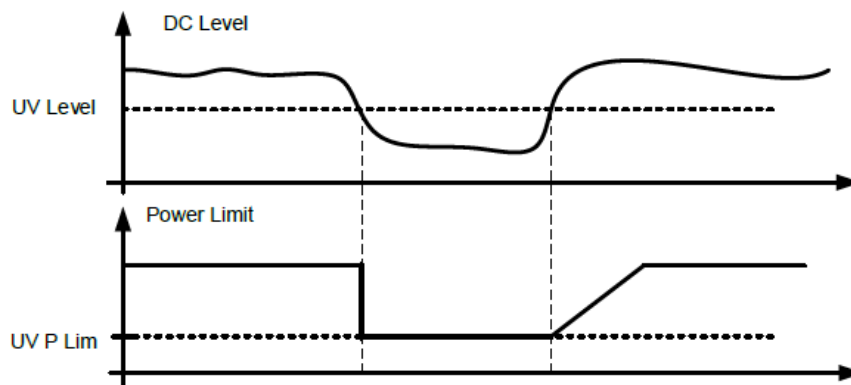

Figure 65: Operation principle of Undervoltage Level for Power Limit.

With the overall power limit (**No. 3165**), a maximum limit value can be defined for both the motoring and regenerative limits. If the overall limit is smaller than a limit defined by any other source, the

overall limit will regulate the power. Finally, both power limits are converted to torque and fed to the torque limit chain. The power limits apply regardless of the drive Control Mode.

P2.3.4.1 Overall Power Limit No. 3165

Set the overall power limit both for the motor and regenerative operations. This limit will apply if it is smaller than any other selected limit. The value is inputted in % of motor nominal power.

P2.3.4.2 Motor Power Limit No. 3167

Set the motor power limit in % of motor nominal power. This is the limit value which is selected by default if no scaling or presets are applied.

P2.3.4.3 Motor Power Limit Scaling Sel. No. 3185

Select the source of scaling the motor power limit. This scaling is applied as a multiplier to the Motor Power Limit parameter value.

No.	Name	Description
0	No Scaling	No scaling is applied.
1	Analog Input	Scaling is applied from analog input. Use parameter No. 3195 to select the terminal.
2	Fieldbus	Scaling is applied from fieldbus with parameter No. 3175 .
3	Minimum of Analog Input and Fieldbus	The smaller value between analog input and fieldbus is applied for scaling.

P2.3.4.4 Motor Power Limit Scaling Input No. 3195

Select the analog input terminal for scaling the motor power limit, if analog input scaling is used.

No.	Name	Description
0	None	No input is selected and a value of 0% is applied to the associated function.
5	50 %	A virtual value of 50 % is applied to the associated function.
10	100 %	A virtual value of 100 % is applied to the associated function.
*	Available analog input terminals	A dynamically generated selection of available analog input terminals is presented as an option. The specific set depends on the type and number of I/O options installed in the system.

P2.3.4.5 Motor Power Limit Preset 1 No. 3170

Set the value of the motor power limit preset 1.

P2.3.4.6 Motor Power Limit Preset 2 No. 3171

Set the value of the motor power limit preset 2.

P2.3.4.7 Motor Power Limit Preset Input 1 No. 3179

Select the first digital input terminal for the binary selection of the motor power limit presets. If neither input is active, no presets are used. If 1 is active, the respective preset is used. If both are active, the limit is set to 0.

No.	Name	Description
0	None (False)	No input is selected. A virtual value of FALSE is applied.
1	None (True)	No input is selected. A virtual value of TRUE is applied.
*	Fieldbus control word 1/2 digital input bits	Fieldbus CTW1 digital input bits 12-15 and CTW2 digital input bits 0-15 will be presented as options.
*	Logic Digital I/O virtual terminals	Virtual digital outputs from the Logic Feature function blocks are presented as input options.
*	Available digital input terminals	A dynamically generated selection of available digital input terminals is presented as an option. The specific set depends on the type and number of I/O options installed in the system.

P2.3.4.8 Motor Power Limit Preset Input 2 No. 3181

Select digital input terminal for the binary selection of the motor power limit presets. If neither input is active, no presets are used. If 1 is active, the respective preset is used. If both are active, the limit is set to 0.

No.	Name	Description
0	None (False)	No input is selected. A virtual value of FALSE is applied.
1	None (True)	No input is selected. A virtual value of TRUE is applied.
*	Fieldbus control word 1/2 digital input bits	Fieldbus CTW1 digital input bits 12-15 and CTW2 digital input bits 0-15 will be presented as options.
*	Logic Digital I/O virtual terminals	Virtual digital outputs from the Logic Feature function blocks are presented as input options.
*	Available digital input terminals	A dynamically generated selection of available digital input terminals is presented as an option. The specific set depends on the type and number of I/O options installed in the system.

P2.3.4.9 Regenerative Power Limit No. 3166

Set the regenerative power limit in % of motor nominal power. This is the limit value which is selected by default if no scaling or presets are applied.

P2.3.4.10 Regenerative Power Limit Scaling Sel. No. 3186

Select the source of scaling the regenerative power limit. This scaling is applied as a multiplier to the Regenerative Power Limit parameter value.

No.	Name	Description
0	No Scaling	No scaling is applied.
1	Analog Input	Scaling is applied from analog input. Use parameter No. 3196 to select the terminal.
2	Fieldbus	Scaling is applied from fieldbus with parameter No. 3176 .
3	Minimum of Analog Input and Fieldbus	The smaller value between analog input and fieldbus is applied for scaling.

P2.3.4.11 Regenerative Power Limit Scaling Input**No. 3196**

Select the analog input terminal for scaling the regenerative power limit, if analog input scaling is used.

No.	Name	Description
0	None	No input is selected and a value of 0% is applied to the associated function.
5	50 %	A virtual value of 50 % is applied to the associated function.
10	100 %	A virtual value of 100 % is applied to the associated function.
*	Available analog input terminals	A dynamically generated selection of available analog input terminals is presented as an option. The specific set depends on the type and number of I/O options installed in the system.

P2.3.4.12 Regenerative Power Limit Preset 1**No. 3168**

Set the value of the regenerative power limit preset 1.

P2.3.4.13 Regenerative Power Limit Preset 2**No. 3169**

Set the value of the regenerative power limit preset 2.

P2.3.4.14 Regenerative Power Limit Preset Input 1**No. 3180**

Select the first digital input terminal for the binary selection of the regenerative power limit presets. If neither input is active, no presets are used. If 1 is active, the respective preset is used. If both are active, the limit is set to 0.

No.	Name	Description
0	None (False)	No input is selected. A virtual value of FALSE is applied.
1	None (True)	No input is selected. A virtual value of TRUE is applied.
*	Fieldbus control word 1/2 digital input bits	Fieldbus CTW1 digital input bits 12-15 and CTW2 digital input bits 0-15 will be presented as options.
*	Logic Digital I/O virtual terminals	Virtual digital outputs from the Logic Feature function blocks are presented as input options.
*	Available digital input terminals	A dynamically generated selection of available digital input terminals is presented as an option. The specific set depends on the type and number of I/O options installed in the system.

P2.3.4.15 Regenerative Power Limit Preset Input 2**No. 3182**

Select the second digital input terminal for the binary selection of the regenerative power limit presets. If neither input is active, no presets are used. If 1 is active, the respective preset is used. If both are active, the limit is set to 0.

No.	Name	Description
0	None (False)	No input is selected. A virtual value of FALSE is applied.
1	None (True)	No input is selected. A virtual value of TRUE is applied.
*	Fieldbus control word 1/2 digital input bits	Fieldbus CTW1 digital input bits 12-15 and CTW2 digital input bits 0-15 will be presented as options.
*	Logic Digital I/O virtual terminals	Virtual digital outputs from the Logic Feature function blocks are presented as input options.
*	Available digital input terminals	A dynamically generated selection of available digital input

No.	Name	Description
		terminals is presented as an option. The specific set depends on the type and number of I/O options installed in the system.

P2.3.4.16 Power Follower Mode No. 3173

Enable or disable the power follower. Available for the motoring limit only.

No.	Name	Description
0	Disabled	
1	Enabled	

P2.3.4.17 Power Follower Hysteresis No. 3174

Set the power follower hysteresis value in % of nominal power.

P2.3.4.18 Undervoltage Limit for Power Limit No. 3177

Set a DC-link voltage limit below which a preset is applied for the motor power limit.

P2.3.4.19 Undervoltage Power Limit Preset No. 3178

Set the value of the preset which is applied if the DC-link voltage goes below the defined limit.

P2.3.4.20 Motor Power Limit Failure Response No. 5173

Set the response to a live zero or fieldbus communication error (fieldbus fault, process data timeout or fieldbus watchdog) for the motoring power limit. This will affect if an analog input is used to scale the limit and the value of the selected terminal goes below its Live Zero Threshold. Or if fieldbus is used to scale the limit, one of the fieldbus communication errors is detected, and the response for the fieldbus error is set to warning.

No.	Name	Description
0	No response	The limit will be taken from the given input regardless of the failure.
1	Preset	The preset limit set with parameter No. 5174 is used.

P2.3.4.21 Motor Power Limit Failure Preset No. 5174

Set the value of the preset applied when the scaling signal experiences errors.

P2.3.4.22 Regen. Power Limit Failure Response No. 5168

Set the response to a live zero or fieldbus communication error (fieldbus fault, process data timeout or fieldbus watchdog) for the regenerative torque limit. This will affect if an analog input is used to scale the limit and the value of the selected terminal goes below its Live Zero Threshold. Or if fieldbus is used to scale the limit, one of the fieldbus communication errors is detected, and the response for the fieldbus error is set to warning.

No.	Name	Description
0	No response	The limit will be taken from the given input regardless of the failure.
1	Preset	The preset limit set with parameter No. 5248 is used.

P2.3.4.23 Regen. Power Limit Failure Preset No. 5248

Set the value of the preset applied when the scaling signal experiences errors.

P2.3.4.24 Positive Power Ref. Limit No. 4571

Set a positive limit for the power reference in % of motor nominal power. This limit is applied before the power reference ramp function.

P2.3.4.25 Negative Power Ref. Limit No. 8027

Set a negative power reference limit in % of motor nominal power. This limit is applied before the power reference ramp function.

7.3.3.5 DC Link Voltage Limiters

The purpose of the DC link voltage limiters is to maintain the DC link voltage in sufficient level during operation.

7.3.3.5.1 Undervoltage Limit Controller

The undervoltage protection can be used for example to react to sudden loss of the supply voltage (DC-link voltage). There are several different responses to choose from in this situation with parameter **No. 1818**. The typical response is to try and support the DC-link voltage with the undervoltage controller. Other responses aim to stop the motor in a controlled manner.

The undervoltage controller will reduce the drive's output and decelerate the motor to regenerate energy to the DC-link to support it. If the power loss is very brief, such response may save the motor from stopping completely. The controller is configured with parameters **No. 1806-1808**.

A detection threshold for the undervoltage situation can be defined with either **No. 2901** or a fieldbus signal (**No. 4510**). The threshold is also used as the reference for the undervoltage limit controller. If the fieldbus signal is used it needs to be selected with **No. 2900**. In case the fieldbus signal fails due to Fieldbus Watchdog event, a reaction can be configured with **No. 4502**.

After the supply voltage is back to a secure level the drive will act according to a selected undervoltage recovery response (**No. 1819**). These responses determine how the motor speed is controlled in such a situation.

The undervoltage control operation principle is further explained in the following figure for forward direction and motoring operation. When the measured DC-link voltage is higher than the undervoltage level, the PID controller error (e) is positive, and the internal positive torque limit is at the set level. If the measured DC-link voltage falls below the undervoltage level, the PID controller error is negative, and the internal positive torque limit reduces the motor torque, and therefore speed, so that energy taken from the DC link is reduced. After DC-link voltage recovers from the undervoltage condition, the torque and speed return to their original values.

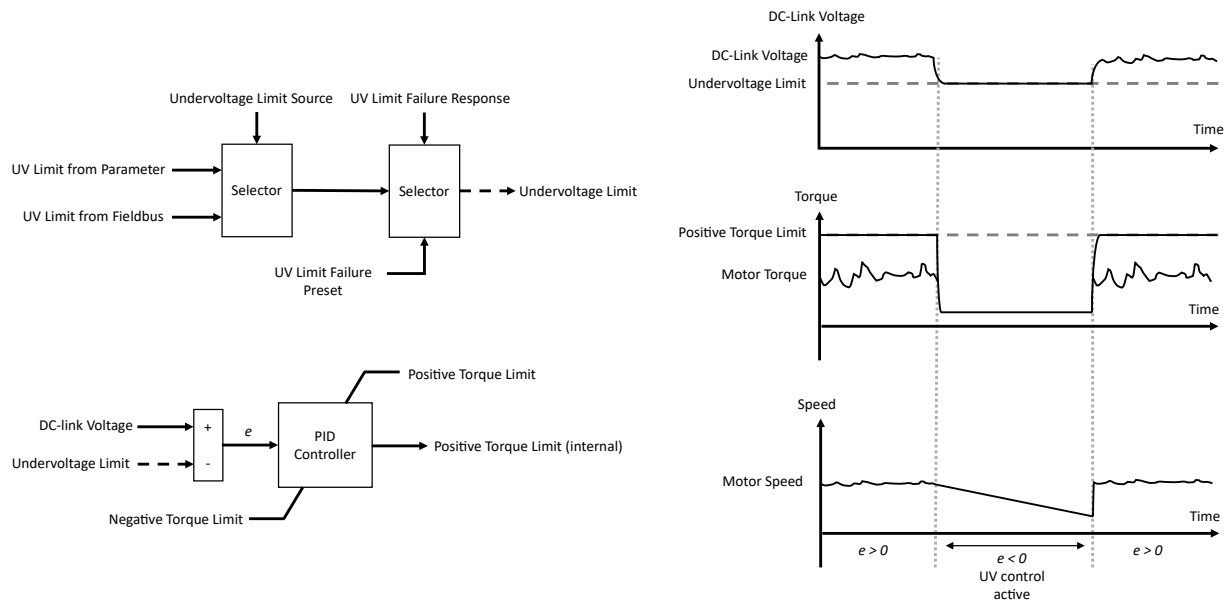

Figure 66: Operation principle of undervoltage limit controller during sudden loss of DC-link voltage.

P2.3.5.1.1 Undervoltage Response

No. 1818

Select the response to low DC link voltage.

No.	Name	Description
0	None	The function is disabled.
1	Undervoltage control	The drive will aim to maintain the DC link voltage in the set undervoltage control limit via the undervoltage control loop.
2	Controlled ramp down	The drive will ramp motor speed to zero before stopping modulation.
3	Coast	The drive will stop modulation immediately.

NOTICE

Options 2 and 3 are effective only in drives with integrated rectifier units. Do not use these options with any other drive types. This parameter can not be edited when the drive is running.

P2.3.5.1.2 Undervoltage Recovery Response **No. 1819**

Select the response to recovering from low DC link voltage.

No.	Name	Description
0	Ramp to reference	The drive will ramp the speed from the actual speed to the reference.
1	Ramp fast to reference	The drive will bypass ramping and jump straight to the reference. Only available with FVC+ principle.
2	Ramp to zero	The drive will ramp the speed from the actual speed to zero and stop modulating. To resume operation, a new start command must be issued.
3	Flystart	Only available if parameter No. 1818 is set to coast. After coasting due to undervoltage situation the drive will resume modulation, detect the motor speed and begin ramping to reference from the prevailing speed.

NOTICE

Options 1-3 are effective only in drives with integrated rectifier units. Do not use these options with any other drive types. This parameter can not be edited when the drive is running.

P2.3.5.1.3 Undervoltage Control Kp **No. 1806**

Set the scaling of the undervoltage control proportional gain.

P2.3.5.1.4 Undervoltage Control Ti **No. 1807**

Set the scaling of the undervoltage control integral time.

P2.3.5.1.5 Undervoltage Control Td **No. 1808**

Set the scaling of the undervoltage control derivation time.

P2.3.5.1.6 Undervoltage Limit Source **No. 2900**

Select the source for the DC-link undervoltage controller limit.

No.	Name	Description
0	Parameter	The undervoltage limit is taken from parameter No. 2901 .
1	Fieldbus	The undervoltage limit is taken from fieldbus via parameter No. 4510 .

P2.3.5.1.7 Undervoltage Limit **No. 2901**

Set the DC-link undervoltage limit in % of the DC-link nominal voltage.

P2.3.5.1.8 UV Limit Failure Response **No. 4502**

Select fieldbus communication error protection (fieldbus fault, process data timeout or fieldbus watchdog) for fieldbus undervoltage limit. When set to "Preset", and one of the fieldbus communication errors is detected with response for the error set to warning, the UV limit is taken from parameter **No. 2948**.

No.	Name	Description
0	No response	The undervoltage limit will be taken from fieldbus regardless of the failure.
1	Preset	The preset limit set with parameter No. 2948 is used.

P2.3.5.1.9 UV Limit Failure Preset **No. 2948**

Set the value of the preset applied when the fieldbus signal experiences errors.

P2.3.5.1.10 Deceleration Time Power Loss **No. 1139**

Set the deceleration time from nominal speed to 0 when in undervoltage control. This time applies to the speed ramp only if the controlled ramp down option is selected for the undervoltage response with parameter **No. 1818**.

7.3.3.5.2 Overvoltage Limit Controller

The overvoltage limit controller can be used to protect the DC-link of the drive from unacceptably high voltage levels. When activated, the controller can limit the motor speed or its deceleration to prevent the DC-link voltage from rising above the overvoltage limit.

The controller must be enabled with parameter **No. 1802**. Then the controller can be tuned with parameters **No. 1803-1305**.

The controller activates if the DC-link voltage exceeds the limit set with either parameter **No. 2898** or a fieldbus signal (**No. 4512**). The controller uses this limit as its reference. The selection between parameter and fieldbus is made with **No. 2897**. In case the fieldbus signal fails, due to a Fieldbus Watchdog event for example, a reaction can be configured with **No. 4501**.

The overvoltage control operation principle is further explained in the following figure for forward direction and motoring operation. When the measured DC-link voltage is lower than the overvoltage limit, the PID controller error (e) is negative, and the internal negative torque limit is at the set level. The drive is then decelerated, which causes the measured DC-link voltage to exceed the overvoltage limit. In this situation the PID controller error is positive, which raises the internal negative torque limit to reduce the motor decelerating torque, and therefore the rate of change of the speed, so the energy dissipated from the motor to the DC-link is reduced. After the deceleration is over, the DC-link voltage and torque limit return to their original values.

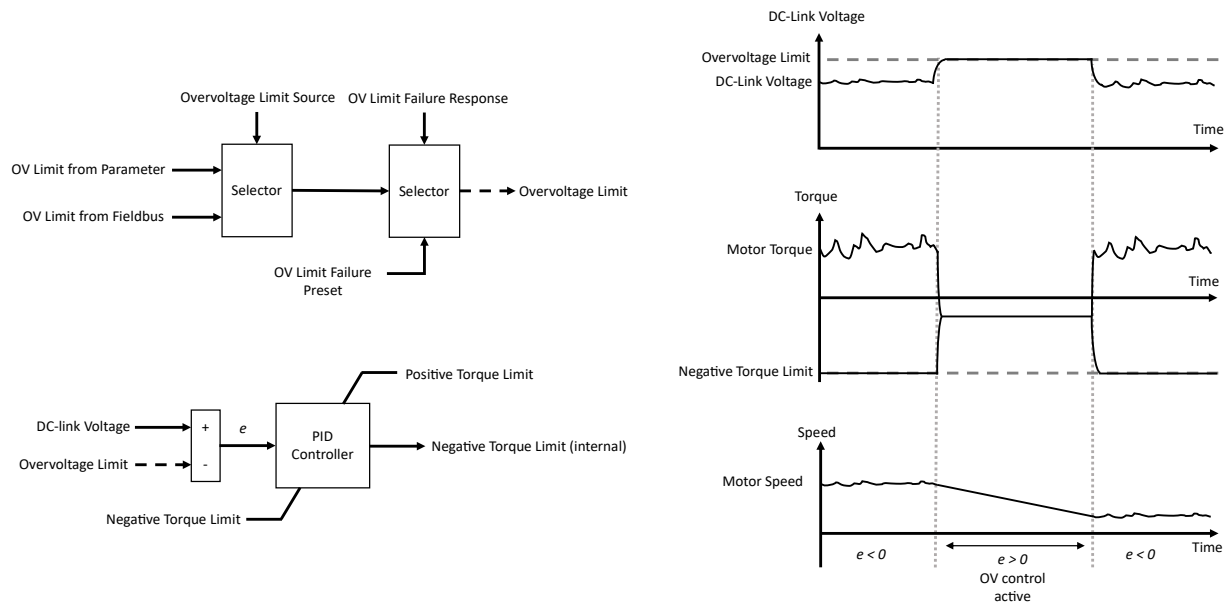

Figure 67: Operation principle of overvoltage limit controller during deceleration.

P2.3.5.2.1 Overvoltage Control No. 1802

Enables the DC-link overvoltage controller. It is recommended to disable the overvoltage controller if brake chopper is enabled, or the unit is supplied with a regulated DC.

No.	Name	Description
0	Disabled	
1	Enabled	

P2.3.5.2.2 Overvoltage Control Kp No. 1803

Set the scaling of the overvoltage control proportional gain.

P2.3.5.2.3 Overvoltage Control Ti No. 1804

Set the scaling of the overvoltage control integral time.

P2.3.5.2.4 Overvoltage Control Td No. 1805

Set the scaling of the overvoltage control derivation time.

P2.3.5.2.5 Overvoltage Limit Source No. 2897

Select the source for the DC-link overvoltage controller limit.

No.	Name	Description
0	Parameter	The overvoltage limit is taken from parameter No. 2898 .
1	Fieldbus	The overvoltage limit is taken from fieldbus via parameter No. 4512 .

P2.3.5.2.6 Overvoltage Limit No. 2898

Set the DC-link overvoltage limit in % of the DC-link nominal voltage.

P2.3.5.2.7 OV Limit Failure Response **No. 4501**

Select fieldbus communication error protection (fieldbus fault, process data timeout or fieldbus watchdog) for fieldbus overvoltage limit. When set to "Preset", and one of the fieldbus communication errors is detected with response for the error set to warning, the OV limit is taken from parameter **No. 2911**.

No.	Name	Description
0	No response	The overvoltage limit will be taken from fieldbus regardless of the failure.
1	Preset	The preset limit set with parameter No. 2911 is used.

P2.3.5.2.8 OV Limit Failure Preset **No. 2911**

Set the value of the preset applied when the fieldbus signal experiences errors.

7.3.3.5.3 Brake Chopper

This group houses the internal brake chopper parameters.

NOTICE

This group is only visible in drives with integrated brake chopper units.

P2.3.5.3.1 Brake Chopper **No. 2935**

Select the brake chopper operation mode.

No.	Name	Description
0	Disabled	Brake chopper is disabled.
1	Enabled in Run and Coast	Enables the brake chopper always.
2	Enabled in run only	Enables the brake chopper only while running.

P2.3.5.3.2 Brake Chopper Voltage Reduce **No. 2938**

Set the activation level of the brake chopper. If set to 0, the brake chopper is active if the voltage exceeds the overvoltage limit (**No. 2898** or **No. 4512**). The value set is subtracted from the overvoltage control limit, lowering the brake chopper activation level, respectively.

P2.3.5.3.3 Brake Resistor Resistance **No. 2936**

Set the resistance value of the brake resistor.

P2.3.5.3.4 Brake Resistor Power Limit **No. 2937**

Set the power limit for resistor braking.

P2.3.5.3.5 Brake Resistor Test **No. 430**

Enables the brake resistor test. The drive conducts a test of brake resistor presence while the drive is stopped. Starting of the drive is prohibited until the test is completed.

No.	Name	Description
0	Off	Function is disabled.
1	Enable brake chopper test run	Executes the brake chopper and brake resistor test to check if they are operational.

7.3.3.5.4 DC Voltage Drooping

DC voltage drooping is used to balance the load between multiple converters that are controlling the same DC-link voltage in overvoltage or undervoltage control. Voltage limits are modified according to the following figure as a function of torque or power. For example, if one drive is generating more power to the DC-link than the others, its overvoltage limit is reduced most, which reduces its generating power in relation to the other converters.

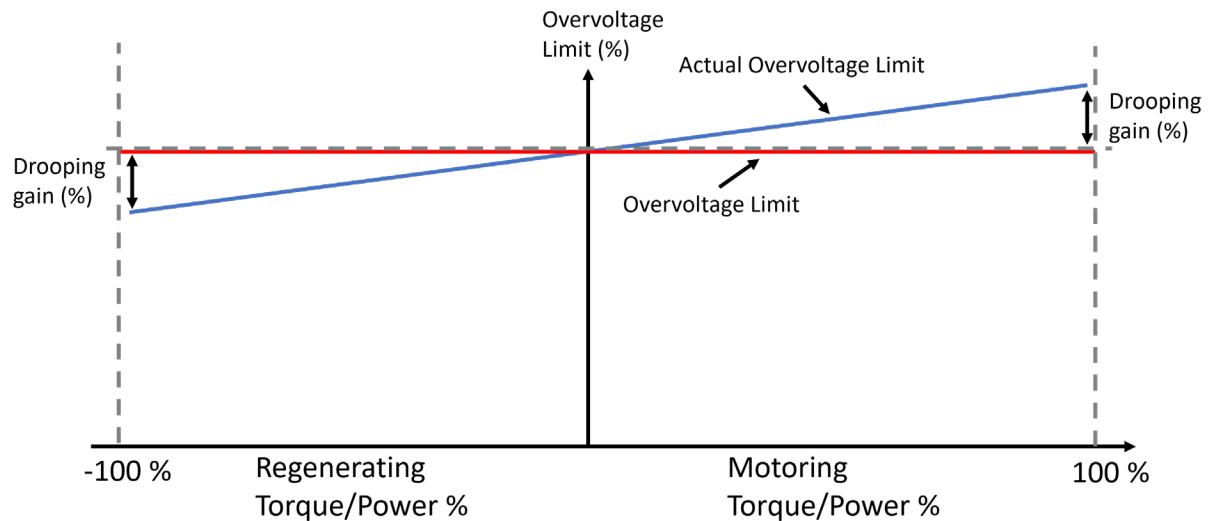

Figure 68: Operation principle of DC voltage drooping.

P2.3.5.4.1 DC Voltage Drooping Mode

No. 4619

Input signal for DC voltage drooping.

No.	Name	Description
0	Torque	Use motor torque.
1	Power	Use motor power.

P2.3.5.4.2 DC-link Voltage Droop Gain

No. 2912

Set the DC-link voltage drooping gain. Change of overvoltage limit per torque/power change.

P2.3.5.4.3 DC-link Voltage Droop. Tc

No. 5095

Filtering time constant of active current used for calculating motor torque and power when DC-link voltage drooping is used.

7.3.4 Ramps

7.3.4.1 Speed Ramps

The application offers various settings for configuring ramps for speed control. Acceleration, deceleration, and s-curve settings can be configured for the different speed ramps.

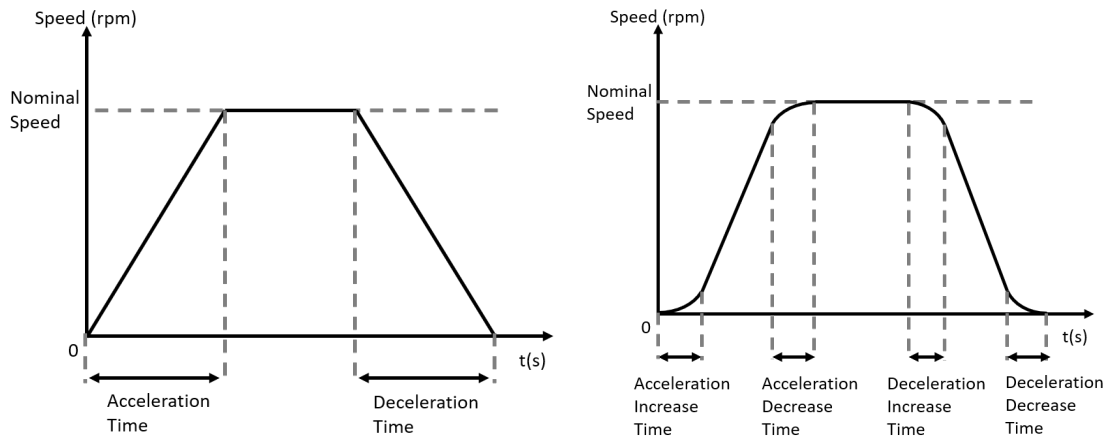

Figure 69: Definition of speed ramps. Left: Normal ramp. Right: S-Ramp.

The two different ramp presets are available with identical settings. The preset in use can be switched with a digital input signal (parameter **No. 1130**). The switch is instantaneous and can be done while the drive is running.

If a fault has been configured to stop the drive with a ramp, the ramp will behave according to the configuration of the active ramp preset.

With parameter **No. 5504** it can also be defined whether the motor speed is ramped or allowed to step to the speed reference after recovering from limit control. With parameter **No. 4405** the maximum allowed motor speed windup after recovering from a limiting condition can be defined. Within this gap the motor speed follows the speed reference with the speed controller dynamics.

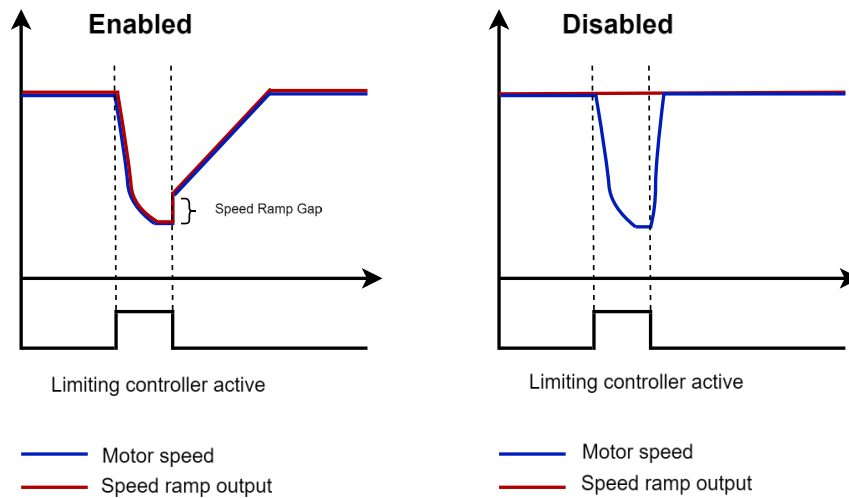

Figure 70: Operation principle of speed ramp gap.

7.3.4.1.1 Speed Ramp Settings

P2.4.1.1.1 Speed Ramp Selection Input **No. 1130**

Select the input terminal for selecting between the speed ramps 1 and 2. Ramp 1 is used when input is deactivated, and ramp 2 is used with activated input.

No.	Name	Description
0	None (Ramp 1)	No input is used. Ramp 1 is selected.
1	None (Ramp 2)	No input is used. Ramp 2 is selected.
*	Fieldbus control word 1/2 digital input bits	Fieldbus CTW1 digital input bits 12-15 and CTW2 digital input bits 0-15 will be presented as options.
*	Logic Digital I/O virtual terminals	Virtual digital outputs from the Logic Feature function blocks are presented as input options.
*	Available digital input terminals	A dynamically generated selection of available digital input terminals is presented as an option. The specific set depends on the type and number of I/O options installed in the system.

P2.4.1.1.2 Enable Speed Ramp Gap No. 5504

Defines whether the motor speed is ramped or allowed to step to the speed reference after recovering from limit control. When enabled the motor speed is ramped. When disabled the motor speed heads directly to given reference according to speed controller dynamics.

No.	Name	Description
0	Disabled	
1	Enabled	

P2.4.1.1.3 Speed Ramp Gap No. 5505

Set the maximum allowed motor speed windup after recovering from a limiting condition. Within this gap the motor speed follows the speed reference with the speed controller dynamics.

7.3.4.1.2 Ramp 1

P2.4.1.2.1 Ramp 1 Accel. Time No. 1101

Acceleration time from 0 Hz to Nominal Speed in Hz for speed ramp 1.

P2.4.1.2.2 Ramp 1 Decel. Time No. 1105

Deceleration time from Nominal Speed in Hz to 0 Hz for speed ramp 1.

P2.4.1.2.3 S-Ramp 1 Accel. Increase Time No. 1109

Ramp 1 Acceleration Increase Time For S-Ramp.

P2.4.1.2.4 S-Ramp 1 Accel. Decrease Time No. 1113

Ramp 1 Acceleration Decrease Time For S-Ramp.

P2.4.1.2.5 S-Ramp 1 Decel. Increase Time No. 1117

Ramp 1 Deceleration Increase Time For S-Ramp.

P2.4.1.2.6 S-Ramp 1 Decel. Decrease Time No. 1121

Ramp 1 Deceleration Decrease Time For S-Ramp.

7.3.4.1.3 Ramp 2

P2.4.1.3.1 Ramp 2 Accel. Time No. 1106

Acceleration time from 0 Hz to Nominal Speed in Hz for speed ramp 2.

P2.4.1.3.2 Ramp 2 Decel. Time No. 1102
Deceleration time from Nominal Speed in Hz to 0 Hz for speed ramp 2.

P2.4.1.3.3 S-Ramp 2 Accel. Increase Time No. 1110
Ramp 2 Acceleration Increase Time For S-Ramp.

P2.4.1.3.4 S-Ramp 2 Accel. Decrease Time No. 1114
Ramp 2 Acceleration Decrease Time For S-Ramp.

P2.4.1.3.5 S-Ramp 2 Decel. Increase Time No. 1118
Ramp 2 Deceleration Increase Time For S-Ramp.

P2.4.1.3.6 S-Ramp 2 Decel. Decrease Time No. 1122
Ramp 2 Deceleration Decrease Time For S-Ramp.

7.3.4.2 Torque Ramp

Ramping functions for both torque reference and limit are provided. Rates are given in percentage of motor nominal torque per second (%/s). The reference ramp rates can be defined separately for the increasing and decreasing reference either by parameters **No. 2350** and **No. 2351** or via fieldbus signals **No. 2353** and **No. 2354**. For the limit, a rate can be set for increasing the limit with parameter **No. 3153**, while decreasing the limit is always instantaneous.

P2.4.2.1 Torque Ref. Increase Rate No. 2350
Set an increasing rate for ramping the torque reference in %/s. Setting this parameter to 0 %/s will bypass ramping up.

P2.4.2.2 Torque Ref. Decrease Rate No. 2351
Set a decreasing rate for ramping the torque reference in %/s. Setting this parameter to 0 %/s will bypass ramping down.

P2.4.2.3 Torque Ref. Ramp Rate Source No. 2352
Select whether the torque reference increase and decrease rates are set via fieldbus or parameters.

No.	Name	Description
0	Parameter	Increase rate is set with parameter No. 2350 . Decrease rate is set with parameter No. 2351 .
1	Fieldbus	Increase rate is set with fieldbus signal No. 2353 . Decrease rate is set with fieldbus signal No. 2354 .

P2.4.2.4 Torque Limit Increase Rate No. 3153
Set an increasing rate for ramping the torque limit in %/s. No ramping is applied when the limit is decreased or if this parameter is set to 0.

7.3.4.3 Power Ramp

Ramping functions for both the power reference and limit are provided. Rates are given in percentage of motor nominal power per second (%/s). The reference ramp rates can be defined separately for the increasing and decreasing reference either by parameters **No. 4572**, **No. 4576** or via fieldbus signals

No. 4538, No. 4539. For the limit, the rate can be set for increasing the limit with a parameter **No. 3172** or fieldbus signal **No. 4529**, while decreasing the limit is always instantaneous.

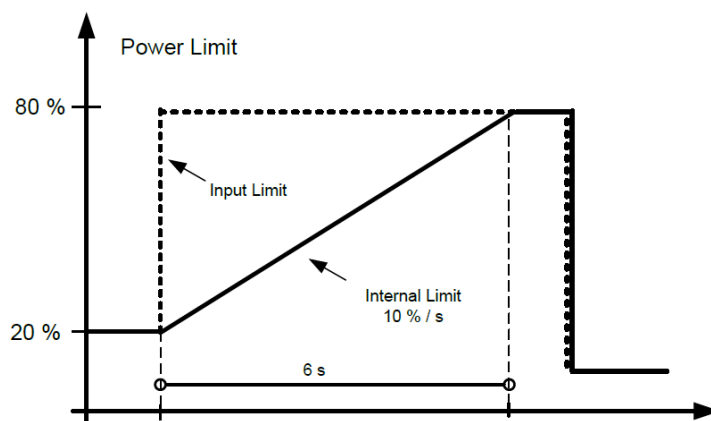

Figure 71: Definition of power limit increase rate.

P2.4.3.1 Power Ref. Increase Rate No. 4572

Set an increasing rate for ramping the power reference in %/s. Setting this parameter to 0 %/s will bypass ramping up.

P2.4.3.2 Power Ref. Decrease Rate No. 4576

Set a decreasing rate for ramping the power reference in %/s. Setting this parameter to 0 %/s will bypass ramping down.

P2.4.3.3 Power Ref. Ramp Rate Source No. 4577

Select whether the power reference increase and decrease rates are set via fieldbus or parameters.

No.	Name	Description
0	Parameter	Increase rate is set with parameter No. 4572 . Decrease rate is set with parameter No. 4576 .
1	Fieldbus	Increase rate is set with fieldbus signal No. 4538 . Decrease rate is set with fieldbus signal No. 4539 .

P2.4.3.4 Power Limit Increase Rate No. 3172

Set the increase rate in percent/second for the power limit. If the value is 0 then the ramp function is bypassed.

P2.4.3.5 Power Limit Ramp Rate Source No. 3200

Select whether power limit ramp rate is set via parameter or fieldbus.

No.	Name	Description
0	Parameter	Increase rate is set with parameter No. 3172 .
1	Fieldbus	Increase rate is set with fieldbus signal No. 4529 .

7.3.5 Digital and Analog Inputs

7.3.5.1 Digital Inputs

This group is a collection of all the digital input sink selection parameters. All these parameters have the following options:

No.	Name	Description
0	None (False)	No input is selected. A virtual value of FALSE is applied.
1	None (True)	No input is selected. A virtual value of TRUE is applied.
*	Fieldbus control word 1/2 digital input bits	Fieldbus CTW1 digital input bits 12-15 and CTW2 digital input bits 0-15 will be presented as options.
*	Logic Digital I/O virtual terminals	Virtual digital outputs from the Logic Feature function blocks are presented as input options.
*	Available digital input terminals	A dynamically generated selection of available digital input terminals is presented as an option. The specific set depends on the type and number of I/O options installed in the system.

P2.5.1.1 I/O Start Forward Input **No. 200**

Select the input source for the start forward command for when the drive operates in I/O control.

* No fieldbus control word 1/2 digital input bits -options

** Additional option: 8201 Logic Start

P2.5.1.2 I/O Start Backward Input **No. 210**

Select the input source for the start backward command for when the drive operates in I/O control.

* No fieldbus control word 1/2 digital input bits -options

** Additional option: 8201 Logic Start

P2.5.1.3 I/O Ramp Stop Inverse Input **No. 201**

Select the input source for the inverted ramp stop command when the drive operates in I/O control.

* No fieldbus control word 1/2 digital input bits -options

** Additional option: 8202 Logic Stop

P2.5.1.4 I/O Coast Inverse Input **No. 202**

Select the input source for the inverted coast stop command when the drive operates in I/O control.

* No fieldbus control word 1/2 digital input bits -options

** Additional option: 8203 Logic Coast

P2.5.1.5 I/O Reset Input **No. 203**

Select the input source for the reset command for when the drive operates in I/O control.

* No fieldbus control word 1/2 digital input bits -options

** Additional option: 8205 Logic Reset

P2.5.1.6 I/O Reverse Input **No. 204**

Select the input source for the reversing command for when the drive operates in I/O control.

* No fieldbus control word 1/2 digital input bits -options

** Additional option: 8204 Logic Reverse

P2.5.1.7 Advanced Start Forward Input **No. 4722**

Select inputs for starting in the forward direction when operating in advanced control.

* Additional option: 2 Fieldbus Start

** Additional option: 8201 Logic Start

P2.5.1.8 Advanced Start Backward Input No. 4725

Select inputs for starting in the backward direction when operating in advanced control.

* Additional option: 2 Fieldbus Start

** Additional option: 8201 Logic Start

P2.5.1.9 Adv. Ramp Stop Inverse Input No. 4723

Select inputs for inverted ramp stopping when operating in advanced control.

* Additional option: 2 Fieldbus Stop

** Additional option: 8202 Logic Stop

P2.5.1.10 Advanced Coast Inverse Input No. 4724

Select inputs for the coast when operating in advanced control. False means the drive is coasted.

* Additional option: 2 Fieldbus coast

** Additional option: 8203 Logic Coast

P2.5.1.11 Advanced Reset Input No. 4731

Select inputs for resetting faults when operating in advanced control.

* Additional option: 2 Fieldbus reset

** Additional option: 8205 Logic Reset

P2.5.1.12 Advanced Reversing Input No. 4730

Select inputs for inverting the reference signal when operating in advanced control. The reverse command does not provide a start signal.

* Additional option: 2 Fieldbus reverse

** Additional option: 8204 Logic Reverse

P2.5.1.13 Run Enable Input No. 103

Select an input enabling the drive to run.

P2.5.1.14 Quick Stop Input No. 215

Select an input terminal for activating the Quick Stop function.

P2.5.1.15 Quick Stop Inverse Input No. 4601

Select an input terminal for activating the Quick Stop Inverse function.

P2.5.1.16 Run Interlock Input 1 No. 4715

Select an input for Run Interlock 1. When active this signal will block the Run Request in all conditions.

P2.5.1.17 Run Interlock Input 2 No. 4716

Select an input for Run Interlock 2. When active this signal will block the Run Request in all conditions.

P2.5.1.18 Start Interlock Input 1 No. 4713

Select an input for Start Interlock 1. When active this signal will block the start, but its deactivation will not stop the drive.

P2.5.1.19 Start Interlock Input 2 No. 4714

Select an input for Start Interlock 2. When active this signal will block the start, but its deactivation will not stop the drive.

P2.5.1.20 Breaker Control Enable Input No. 4735

Select the input terminal for enabling motor breaker control.

P2.5.1.21 Breaker Manual Close Input No. 4705

Select the digital input terminal for the manual breaker closing command. Note: this terminal is used state-based for both closing and opening commands when Command Signal Mode is set to "Common CL/OP (state)". This same terminal is used for a pulse-based close command when the Command Signal Mode is set to "Separate CL/OP (Pulse)".

P2.5.1.22 Breaker Manual Open Input No. 4706

Select the digital input terminal for the manual breaker opening command. Note: this terminal is used only when Command Signal Mode is set to "Separate CL/OP (Pulse)".

P2.5.1.23 Breaker Close Feedback Input No. 4707

Select the digital input terminal for the breaker close-status feedback. Note: this terminal is used for both closed- and open-status when Feedback Signal Mode is set to "Common CL/OP Signal". This same terminal is used for close status only, when the Feedback Signal Mode is set to "Separate CL/OP Signals".

P2.5.1.24 Breaker Open Feedback Input No. 4708

Select the digital input terminal for the breaker open-status feedback. Note: this terminal is used only when Feedback Signal Mode is set to "Separate CL/OP Signals".

P2.5.1.25 Brake Closed Input No. 3011

Select the input terminal for a closed signal from the mechanical brake.

P2.5.1.26 Brake Open Input No. 3010

Select the input terminal for an open indication signal from the mechanical brake.

P2.5.1.27 Enable Inching Input No. 1080

Select a terminal to enable inching.

P2.5.1.28 Inching Activate Input 1 No. 1084

Select the terminal to inching with reference 1. Enable inching input must be active.

P2.5.1.29 Inching Activate Input 2 No. 1086

Select the terminal to inching with reference 2. Enable inching input must be active.

P2.5.1.30 Freeze Input No. 1008

Select the digital input for freezing the reference. Freezing is used to control the speed reference with 2 digital inputs, 1 increasing the reference and the other decreasing the reference.

P2.5.1.31 Freeze Up Input No. 1001

Select the digital input for increasing the reference while reference freezing is activated.

P2.5.1.32 Freeze Down Input No. 1002

Select the digital input for decreasing the reference while reference freezing is activated.

P2.5.1.33 Preset Speed Reference Bit 0 Input No. 711

Select the digital input used as bit 0 addressing the preset reference.

P2.5.1.34 Preset Speed Reference Bit 1 Input No. 712

Select the digital input used as bit 1 for addressing the preset reference.

P2.5.1.35 Preset Speed Reference Bit 2 Input No. 713

Select the digital input used as bit 2 for addressing the preset reference.

P2.5.1.36 Motor Torque Limit Preset Input No. 3150

Select an input which is used to enable the motor torque limit preset.

P2.5.1.37 Regenerative Torque Limit Preset Input No. 3162

Select an input which is used to enable the regenerative torque limit preset.

P2.5.1.38 Motor Power Limit Preset Input 1 No. 3179

Select the first digital input terminal for the binary selection of the motor power limit presets. If neither input is active, no presets are used. If 1 is active, the respective preset is used. If both are active, the limit is set to 0.

P2.5.1.39 Motor Power Limit Preset Input 2 No. 3181

Select digital input terminal for the binary selection of the motor power limit presets. If neither input is active, no presets are used. If 1 is active, the respective preset is used. If both are active, the limit is set to 0.

P2.5.1.40 Regenerative Power Limit Preset Input 1 No. 3180

Select the first digital input terminal for the binary selection of the regenerative power limit presets. If neither input is active, no presets are used. If 1 is active, the respective preset is used. If both are active, the limit is set to 0.

P2.5.1.41 Regenerative Power Limit Preset Input 2 No. 3182

Select the second digital input terminal for the binary selection of the regenerative power limit presets. If neither input is active, no presets are used. If 1 is active, the respective preset is used. If both are active, the limit is set to 0.

P2.5.1.42 Control Mode Preset Input 1 No. 3469

Select the first digital input terminal for the selection of the control mode preset.

P2.5.1.43 Control Mode Preset Input 2 No. 3470

Select the second digital input terminal for the selection of the control mode preset.

P2.5.1.44 I/O Speed Reference Toggle Input No. 1940

Select an input for toggling between the 2 speed reference sources selected, when operating in I/O control and toggling logic is used. A low signal selects the 1st source and high signal selects the 2nd source.

P2.5.1.45 Fieldbus Speed Reference Toggle Input No. 1939

Select an input for toggling between the 2 speed reference sources selected, when operating in fieldbus control and toggling logic is used. A low signal selects the 1st source and high signal selects the 2nd source.

P2.5.1.46 Adv. Speed Reference Toggle Input No. 1941

Select an input for toggling between the 2 speed reference sources selected, when operating in advanced control and toggling logic is used. A low signal selects the 1st source and high signal selects the 2nd source.

P2.5.1.47 Speed Ramp Selection Input No. 1130

Select the input terminal for selecting between the speed ramps 1 and 2. Ramp 1 is used when input is deactivated, and ramp 2 is used with activated input.

0: None (Ramp 1)

1: None (Ramp 2)

P2.5.1.48 Load Drooping Assist Force Off Input No. 4585

Select the digital input for forcing off the load drooping assist, for example during emergency situations. When input is applied the output of the load drooping assist will decay to 0 according to load drooping assist filter Tc.

P2.5.1.49 External Event 1 Input No. 4557

Select an input for the external event.

P2.5.1.50 Ext. Event 1 Inverse Input No. 4558

Select an inverted input for the external event 1 function.

P2.5.1.51 External Event 2 Input No. 4560

Select an input for the external event.

P2.5.1.52 Ext. Event 2 Inverse Input No. 4561

Select an inverted input for the external event 2 function.

P2.5.1.53 Cooling Monitor Input No. 2400

Select the input for the negated cooling monitor signal.

P2.5.1.54 Positive Speed Ref. Limit Sel Input No. 3212

Select an input for the selection between limit 1 and 2 for the positive rotation direction. Limit 1 is selected when this signal is inactive and limit 2 is selected when this signal is active.

P2.5.1.55 Negative Speed Ref. Limit Sel Input No. 3215

Select an input for the selection of the speed reference limit in the negative rotation direction. Limit 1 is selected when the signal is inactive and limit 2 is selected when the signal is active.

P2.5.1.56 Force I/O Control Input No. 4513

Select an input terminal for forcing the control place to I/O.

P2.5.1.57 Force FB Control Input No. 4511

Select an input terminal for forcing the control place to Fieldbus.

P2.5.1.58 Force Advanced Control Input No. 4721
Select an input terminal for forcing the control place to advanced control.

P2.5.1.59 Thermal Switch Input No. 3414
Select the digital input terminal for the thermal switch.

7.3.5.2 Analog Inputs

This group is a collection of all the analog input terminal selection parameters. All these parameters have the following options:

No.	Name	Description
0	None	No input is selected and a value of 0% is applied to the associated function.
5	50 %	A virtual value of 50 % is applied to the associated function.
10	100 %	A virtual value of 100 % is applied to the associated function.
*	Available analog input terminals	A dynamically generated selection of available analog input terminals is presented as an option. The specific set depends on the type and number of I/O options installed in the system.

P2.5.2.1 Speed Reference 1 Input No. 501
Select the input terminal or a predefined fixed value for the speed reference.

P2.5.2.2 Speed Reference 2 Input No. 502
Select the input terminal or a predefined fixed value for the speed reference.

P2.5.2.3 Analog Adjustment Input No. 4515
Select an input terminal if analog input is used as the source.

P2.5.2.4 Torque Reference 1 Input No. 4534
Select the input terminal for torque reference 1.

P2.5.2.5 Torque Reference 2 Input No. 1923
Select the input terminal for torque reference 2.

P2.5.2.6 Power Reference 1 Input No. 4573
Select the input terminal for power reference 1.

P2.5.2.7 Power Reference 2 Input No. 1924
Select the input terminal for power reference 2.

P2.5.2.8 Joystick 1 Input No. 4500
Select the analog input terminal for Joystick 1.

P2.5.2.9 Joystick 2 Input No. 4504
Select the analog input terminal for Joystick 2.

P2.5.2.10 Current Limit Scaling Input No. 3199

Select the analog input terminal to be used when using an analog input to scale the current limit.

P2.5.2.11 Motor Torque Limit Scaling Input No. 3197

Select an input terminal for scaling the motor power limit if analog input scaling is selected.

P2.5.2.12 Regenerative Torque Limit Scaling Input No. 3198

Select an input for scaling the regenerative power limit if analog input scaling is selected.

P2.5.2.13 Motor Power Limit Scaling Input No. 3195

Select the analog input terminal for scaling the motor power limit, if analog input scaling is used.

P2.5.2.14 Regenerative Power Limit Scaling Input No. 3196

Select the analog input terminal for scaling the regenerative power limit, if analog input scaling is used.

P2.5.2.15 Load Drooping Assist Analog Input No. 4583

Select the analog input terminal for the master drive torque in the load drooping assist function.

7.3.6 Digital and Analog Outputs

7.3.6.1 Digital Outputs

This group is a collection of all the digital output sink selection parameters. All these parameters have the following options:

No.	Name	Description
0	None	No output is selected.
*	Fieldbus status word 2 digital output bits	Fieldbus CTW2 digital output bits 0-15 will be presented as options.
*	Logic Digital I/O virtual terminals	Virtual digital inputs to the Logic Feature function blocks will be presented as output options.
*	Available digital output and relay terminals	A dynamically generated selection of available digital output and relay terminals is presented as an option. The specific set depends on the type and number of I/O options installed in the system.

P2.6.1.1 Ready Output No. 205

Select an output to indicate that the unit is in ready mode.

P2.6.1.2 Run Output No. 206

Select an output to indicate that the unit is in run mode.

P2.6.1.3 On Reference Output No. 207

Select an output to indicate that the unit is on reference.

P2.6.1.4 Static Fault Output No. 208

Select an output for the Static Fault Active signal.

P2.6.1.5 Static Warning Output No. 209

Select an output for the Static Warning Active signal.

P2.6.1.6 Reverse Output No. 5175

Select an output for the Reversing signal.

P2.6.1.7 Wrong Direction Output No. 5176

Select an output for the Wrong Direction signal. This signal is active when the sign of the speed reference disagrees with the sign of the motor speed.

P2.6.1.8 Toggling Fault Output No. 5180

Select an output for the Toggling Fault signal. This signal goes down for 1 second whenever a new fault is registered while another fault is already active.

P2.6.1.9 Toggling Warning Output No. 5181

Select an output for the Toggling Warning signal. This signal goes down for 1 second whenever a new warning is registered while another warning is already active.

P2.6.1.10 Regulator Active Output No. 5182

Select an output for the Regulator Active signal. This signal is active whenever any motor regulator (UV/OV controller, current limit controller and so on) becomes active.

P2.6.1.11 Drive Overheat Output No. 5183

Select an output for the Drive Overheating signal.

P2.6.1.12 FB CTW Bit 12 Output No. 5193

Select an output for the status of the fieldbus control word bit 12.

P2.6.1.13 FB CTW Bit 13 Output No. 5194

Select an output for the status of the fieldbus control word bit 13.

P2.6.1.14 FB CTW Bit 14 Output No. 5198

Select an output for the status of the fieldbus control word bit 14.

P2.6.1.15 FB CTW Bit 15 Output No. 5191

Select an output for the status of the fieldbus control word bit 15.

P2.6.1.16 Local Control Active Output No. 5178

Select an output terminal indicating that the drive is in local control.

P2.6.1.17 I/O Control Active Output No. 5177

Select an output terminal indicating that the drive is in I/O control.

P2.6.1.18 Fieldbus Control Active Output No. 5197

Select an output terminal indicating that the drive is in fieldbus control.

P2.6.1.19 Advanced Control Active Output No. 4727

Select an output terminal indicating that the drive is in advanced control.

P2.6.1.20 Local Control Forcing Requested Output No. 125

Select an output terminal for the indication that the control place forcing to local control has been requested with the [REM/LOC] button of control panel (output high = requested).

P2.6.1.21 I/O Forcing Requested Output No. 121

Select an output terminal for the indication that the control place forcing to I/O control has been requested (output high = requested).

P2.6.1.22 FB Forcing Requested Output No. 120

Select an output terminal for the indication that the control place forcing to fieldbus control has been requested (output high = requested).

P2.6.1.23 Advanced Forcing Requested Output No. 122

Select an output terminal for the indication that the control place forcing to advanced control has been requested (output high = requested).

P2.6.1.24 Motoring Power Limited Output No. 219

Select an output for the motoring power limited signal. This signal is active when the motoring side power limit controller is active.

P2.6.1.25 Brake Output No. 3007

Select the output terminal for controlling the mechanical brake.

P2.6.1.26 Breaker Close Output No. 4709

Select the digital output terminal for the breaker closing command. Note: this terminal is used state-based for both closing and opening commands when Command Signal Mode is set to "Common CL/OP (state)". This same terminal is used for a pulse-based close command when the Command Signal Mode is set to "Separate CL/OP (Pulse)". A 1 second pulse is used.

P2.6.1.27 Breaker Open Output No. 4710

Select the digital output terminal for the breaker opening command. Note: this terminal is used only when Command Signal Mode is set to "Separate CL/OP (Pulse)". A 1 second pulse is used.

P2.6.1.28 Capacitor Disconnect Output No. 3412

Select the output terminal for disconnecting the capacitor.

P2.6.1.29 Persistent Warning Output No. 126

Select an output for the Persistent Warning Active signal. This signal activates when any warning is registered and deactivates if there are no active warnings and a reset command is given.

P2.6.1.30 Regenerative Power Limited Output No. 223

Select an output for the regenerative power limited signal. This signal is active when the regenerative side power limit controller is active.

P2.6.1.31 Freeze Up Output No. 2442

Select an output terminal for the reference freeze up active signal. For activation the reference freeze and freeze up inputs need to be active, and speed reference needs to be in ramping state upwards.

P2.6.1.32 Freeze Down Output No. 2443

Select an output terminal for the reference freeze down active signal. For activation the reference freeze and freeze down inputs need to be active, and speed reference needs to be in ramping state downwards.

P2.6.1.33 Reset Output No. 2444

Select an output terminal for the reset active signal. This signal stays active for 1 seconds after performing event reset.

7.3.6.2 Delayed Digital Outputs

The delayed digital outputs (DDO) are output functions that can be used to relay drive information to external systems, with additional configurations compared to general outputs. Two sets of DDOs are provided.

The desirable output contents are selected (parameters **No. 8032, No. 8033**) for selected terminals (parameters **No. 8040, No. 8041**) using the function-to-terminal method. After that the selected signals can be inverted (parameters **No. 8034, No. 8035**), and activation (parameter **No. 8036, No. 8037**) and deactivation (parameters **No. 8038, No. 8039**) delays can be defined for them.

P2.6.2.1 Delayed Output 1 Content Sel. No. 8032

Select the function for the delayed digital output 1.

No.	Name	Description
0	Not Used	-
1	Drive Ready Status	Motor control functions are ready for operation.
2	Drive Running Status	The drive is in operation (modulation has started).
3	Reverse Direction	Actual speed is negative.
4	Wrong Direction	The sign of the actual speed differs from the speed reference's sign.
5	On Reference	The actual and reference speeds are equal.
6	Limit Regulators Active	One or more regulators are active.
7	Drive Overheat Warning	The drive's overtemperature protection function is reporting high drive temperatures.
8	Ext. Event Active	External event is active.
9	Live Zero Active	Analog input live zero events is active.
10	Motor Thermal Protection Active	The motor thermal function has estimated high motor temperatures.
11	I/O Control Active	Drive is in I/O Control
12	Advanced Control Active	Drive is in Advanced Control
13	Warning Active (Static)	Warning active
14	Fault Active (Static)	Fault active
15	Local control	Drive is in Local Control.
16	Quick Stop Active	Quick Stop is active.
17	Warning Active (Toggled)	Warning active. The emergence of another warning toggles this signal down for one second.
18	Fault Active (Toggled)	Fault active. The emergence of another fault warning toggles this signal down for one second.
19	Brake Control Active	Mechanical Brake control is active.

No.	Name	Description
20	Inching/Preset Speed Active	Inching is active.
25	CTW1 Bit 12	Fieldbus control word vendor specific bit 12 is active.
26	CTW1 Bit 13	Fieldbus control word vendor specific bit 13 is active.
27	CTW1 Bit 14	Fieldbus control word vendor specific bit 14 is active.
28	CTW1 Bit 15	Fieldbus control word vendor specific bit 15 is active.
29	Motoring Power Limited	Motor power limit is active.
30	Warning Active (Persistent)	A warning has activated and has not been acknowledged.
31	Regenerative Power Limited	Regenerative power limit is active.
32	Freeze Up Active	Reference freeze up active signal. For activation the reference freeze and freeze up inputs need to be active, and speed reference needs to be in ramping state upwards.
33	Freeze Down Active	Reference freeze down active signal. For activation the reference freeze and freeze down inputs need to be active, and speed reference needs to be in ramping state downwards.
34	Reset Active	Reset active signal. This signal stays active for 1 seconds after performing event reset.

P2.6.2.2 Output 1 Inversion **No. 8034**

Invert the delayed digital output 1.

No.	Name	Description
0	Disabled	
*	Enabled	

P2.6.2.3 Delayed Output 1 On Delay **No. 8036**

Set the on delay for the delayed digital output 1.

P2.6.2.4 Delayed Output 1 Off Delay **No. 8038**

Set the off delay for the delayed digital output 1.

P2.6.2.5 Delayed Output 1 Output **No. 8040**

Select the output for transmitting the delayed digital output 1.

No.	Name	Description
0	None	No output is selected.
*	Fieldbus status word 2 digital output bits	Fieldbus CTW2 digital output bits 0-15 are presented as options.
*	Logic Digital I/O virtual terminals	Virtual digital inputs to the Logic Feature function blocks are presented as output options.
*	Available digital output and relay terminals	A dynamically generated selection of available digital output and relay terminals is presented as an option. The specific set depends on the type and number of I/O options installed in the system.

P2.6.2.6 Delayed Output 2 Content Sel. **No. 8033**

Select the function for the delayed digital output 2.

No.	Name	Description
0	Not Used	-
1	Drive Ready Status	Motor control functions are ready for operation.
2	Drive Running Status	The drive is in operation (modulation has started).
3	Reverse Direction	Actual speed is negative.
4	Wrong Direction	The sign of the actual speed differs from the speed reference's sign.
5	On Reference	The actual and reference speeds are equal.
6	Limit Regulators Active	One or more regulators is active.
7	Drive Overheat Warning	The drive's overtemperature protection function is reporting high drive temperatures.
8	Ext. Event Active	External event is active.
9	Live Zero Active	Analog input live zero events is active.
10	Motor Thermal Protection Active	The motor thermal function has estimated high motor temperatures.
11	I/O Control Active	Drive is in I/O Control
12	Advanced Control Active	Drive is in Advanced Control
13	Warning Active (Static)	Warning active
14	Fault Active (Static)	Fault active
15	Local control	Drive is in Local Control.
16	Quick Stop Active	Quick Stop is active.
17	Warning Active (Toggled)	Warning active. The emergence of another warning will toggle this signal down for one second.
18	Fault Active (Toggled)	Fault active. The emergence of another fault warning will toggle this signal down for one second.
19	Brake Control Active	Mechanical Brake control is active.
20	Inching/Presets Speed Active	Inching is active.
25	CTW1 Bit 12	Fieldbus control word vendor specific bit 12 is active.
26	CTW1 Bit 13	Fieldbus control word vendor specific bit 13 is active.
27	CTW1 Bit 14	Fieldbus control word vendor specific bit 14 is active.
28	CTW1 Bit 15	Fieldbus control word vendor specific bit 15 is active.
29	Motoring Power Limited	Motor power limit is active.
30	Warning Active (Persistent)	A warning has activated, and has not been acknowledged.
31	Regenerative Power Limited	Regenerative power limit is active.

P2.6.2.7 Output 2 Inversion

No. 8035

Invert the delayed digital output 2.

No.	Name	Description
0	Disabled	
*	Enabled	

P2.6.2.8 Delayed Output 2 On Delay

No. 8037

Set the on delay for the delayed digital output 2.

P2.6.2.9 Delayed Output 2 Off Delay No. 8039

Set the off delay for the delayed digital output 2.

P2.6.2.10 Delayed Output 2 Output No. 8041

Select the output for transmitting the delayed digital output 2.

No.	Name	Description
0	None	No output is selected.
*	Fieldbus status word 2 digital output bits	Fieldbus CTW2 digital output bits 0-15 are presented as options.
*	Logic Digital I/O virtual terminals	Virtual digital inputs to the Logic Feature function blocks are presented as output options.
*	Available digital output and relay terminals	A dynamically generated selection of available digital output and relay terminals is presented as an option. The specific set depends on the type and number of I/O options installed in the system.

7.3.6.3 Analog outputs

This group is a collection of all the analog output terminal selection parameters of the drive. All these parameters will have the following options:

No.	Name	Description
0	None	No output is selected for the associated parameter.
*	Available analog output terminals	A dynamically generated selection of available analog output terminals is presented as an option. The specific set depends on the type and number of I/O options installed in the system.

P2.6.3.1 Drive DC-link Voltage Output No. 2311

Select the output indicating if the DC-link voltage is within range.

P2.6.3.2 Heat Sink Temperature Output No. 2312

Select the output indicating if the heat sink temperature is within range.

P2.6.3.3 Absolute Output Frequency Output No. 2300

Select an output terminal for the output frequency scaled between 0 Hz and positive speed limits in Hz.

P2.6.3.4 Motor Current Output No. 2302

Select an output for the motor current signal. The scale of the signal is 0 - 100% of the nominal current.

P2.6.3.5 Motor Power Output No. 2305

Select an output for the motor power signal. The scale of the signal is 0 - 100% of the nominal power.

P2.6.3.6 Absolute Motor Torque Output No. 2306

Select an output for the motor torque signal. The scale of the signal is 0 - 100% of the absolute value of the nominal torque.

P2.6.3.7 Extended Motor Torque Output No. 2310
Select an output for the motor torque signal. The scale of the signal is -200...200% of the nominal torque.

P2.6.3.8 Absolute Motor Speed Output No. 2301
Select an output for the motor speed signal. The scale of the signal is 0 - 100% of the absolute value of the nominal speed.

P2.6.3.9 Extended Motor Speed Output No. 2309
Select an output for the motor speed signal. The scale of the signal is -200...200% of the nominal speed.

P2.6.3.10 Motor Voltage Output No. 2303
Select an output for the motor voltage signal. The scale of the signal is 0 - 100% of the nominal voltage.

P2.6.3.11 Absolute Speed Reference Output No. 2304
Select an output terminal for the absolute speed reference, scaled between 0 and positive speed limit.

P2.6.3.12 Output Frequency Output No. 2308
Select an output terminal for the output frequency scaled between minimum speed limit and positive speed limits in Hz.

P2.6.3.13 Scaled Motor Speed Output No. 2430
Select an output terminal for the motor speed scaled between user defined limits.

P2.6.3.14 Scaled Motor Speed Output Max. No. 2431
Set the maximum motor speed for analog output scaling.

P2.6.3.15 Scaled Motor Speed Output Min. No. 2432
Set the minimum motor speed for analog output scaling.

P2.6.3.16 Scaled Speed Reference Output No. 2433
Select an output terminal for the speed reference scaled between user defined limits.

P2.6.3.17 Scaled Speed Reference Output Max. No. 2434
Set the maximum speed reference for analog output scaling.

P2.6.3.18 Scaled Speed Reference Output Min. No. 2435
Set the minimum speed reference for analog output scaling.

P2.6.3.19 Scaled Motor Power Output No. 2439
Select an output terminal for the motor power scaled between user defined limits.

P2.6.3.20 Scaled Motor Power Output Max. No. 2440
Set the maximum motor power for analog output scaling.

P2.6.3.21 Scaled Speed Reference Output Min. No. 2441
Set the minimum motor power for analog output scaling.

P2.6.3.22 Scaled Motor Torque % Output**No. 2436**

Select an output terminal for the motor torque % scaled between user defined limits.

P2.6.3.23 Scaled Motor Torque % Output Max.**No. 2437**

Set the maximum motor torque for analog output scaling.

P2.6.3.24 Scaled Motor Torque % Output Min.**No. 2438**

Set the minimum motor torque for analog output scaling.

7.3.7 Start and Stop Settings**7.3.7.1 Start Settings**

This group contains parameters for start related settings.

For induction motors a motor magnetization period can be configured with parameter **No. 2328** as a start time before speed ramp release. If this parameter is set to -1 the drive automatically determines the magnetization time. For synchronous motors magnetization time is always zero regardless of this parameter.

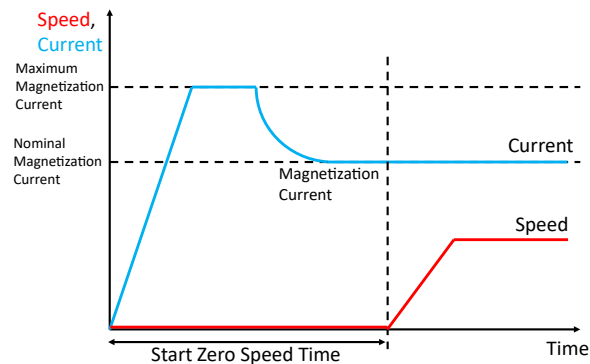

Figure 72: Operation principle of Magnetization Time.

NOTICE

Magnetization time is calculated after DC-start current injection. Note also, that magnetization time applies only in FVC+ mode.

The drive can also be configured to perform a “Flying Start” with parameter **No. 4025**. With flying start the drive detects the actual motor speed and starts operation from the detected speed before ramping to the speed reference. Otherwise, the drive starts operation from zero speed before ramping to the speed reference.

Parameter **No. 4717** defines how the drive responds for an active start command being removed. This parameter can be used to define how the drive stops when a state sensitive start signal is removed.

Additionally, parameter **No. 103** selects a digital input terminal for enabling the drive to run. Using parameter **No. 5110**, a response for a blocked start situation can be defined. Several factors may inhibit the drive from being in ready state and starting to operate.

P2.7.1.1 Magnetization Time**No. 2328**

Set a delay to magnetize the motor or synchronize parallel motors before starting ramping. Set to -1 for automatic calculation.

P2.7.1.2 Flying Start No. 4025

Enables a flying start. The drive detects its current speed at the moment that the start signal is given, and starts to ramp towards the given reference.

No.	Name	Description
0	Disabled	When started with a rotating motor, the drive will first force the motor speed to standstill and start ramping towards the reference from there.
1	Enabled	When started with a rotating motor, the drive will detect the motor speed and start ramping towards the reference from that speed.

P2.7.1.3 Missing Start Response No. 4717

Select the stopping mode when start signal is removed. This parameter is used to define how the drive stops when a state sensitive start command is removed.

No.	Name	Description
0	Coast	
1	Ramp to Standstill	

P2.7.1.4 Start Delay No. 4743

Set a delay to start the drive.

P2.7.1.5 Run Enable Input No. 103

Select an input enabling the drive to run. This signal must be active for the drive to be in the ready state. If the signal is deactivated while the drive is running, the drive will stop modulating immediately and coast stop.

No.	Name	Description
0	None (False)	No input is selected. A virtual value of FALSE is applied.
1	None (True)	No input is selected. A virtual value of TRUE is applied.
*	Fieldbus control word 1/2 digital input bits	Fieldbus CTW1 digital input bits 12-15 and CTW2 digital input bits 0-15 are presented as options.
*	Logic Digital I/O virtual terminals	Virtual digital outputs from the Logic Feature function blocks are presented as input options.
*	Available digital input terminals	A dynamically generated selection of available digital input terminals is presented as an option. The specific set depends on the type and number of I/O options installed in the system.

P2.7.1.6 Start Blocked Response **No. 5110**

Select the drive response for start blocked event. Several factors may inhibit the drive from being in a ready-state and allow starting to operate. If desired, the drive can issue an event if some start conditions are not met.

No.	Name	Description
0	No response	-
1	Info	The drive issues an info event.
3	Warning	The drive issues a warning event.
9	Fault, ramp to coast	The drive issues a fault event and ramp motor speed to zero before stopping modulation.
10	Fault, coast	The drive issues a fault event and stop modulation immediately.

P2.7.1.7 Flying Start Method **No. 4621**

Selects demagnetized flying start method for induction motors.

No.	Name	Description
0	DC Pulses	The speed of the motor is detected using DC pulses.
1	AC Scan	The speed of the motor is detected using an AC scan.

P2.7.1.8 Flying Start Search Direction **No. 4622**

Selects whether the search direction for flying start can be limited by speed limits or not.

No.	Name	Description
0	Based on speed limits	Flying start will not search for the motor in rotating directions limited by speed limit parameters.
1	Both directions	Flying start will search for the motor from both rotating directions regardless of any speed limits.

7.3.7.2 DC Start

The application software provides the possibility to configure a DC start before entering normal motor control, for purposes of motor pre-heating, pre-magnetization, DC holding, or a start delay. DC start current is applied before motor magnetization current. By setting the DC start current level to 0 %, this feature can also be used as a simple start delay.

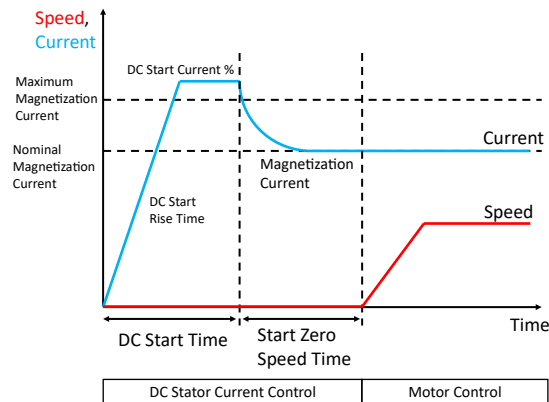

Figure 73: Operation principle of DC Start.

P2.7.2.1 DC Start Time No. 2264

Set the duration of the current injection during DC start.

P2.7.2.2 DC Start Current Rise Time No. 2265

Set the time to ramp the current from 0 to the specified injection level.

P2.7.2.3 DC Start Current No. 2263

Set the DC current in % of nominal motor current. This current is injected during the DC start time.

7.3.7.3 Synchronous Motor Start

This group has parameters for configuring the starting of synchronous motors. The available starting modes are rotor angle detection and rotor angle parking. In the detection mode, a configurable current is fed to the motor to detect the motor position before starting operation. In the parking mode, the rotor position is forced to a set angle before starting operation. If a speed feedback device is available, then rotor angle detection and parking can be skipped by setting the synchronous motor starting mode to disabled. The DC start feature can be used together with synchronous motor starting functions. The DC start is applied first.

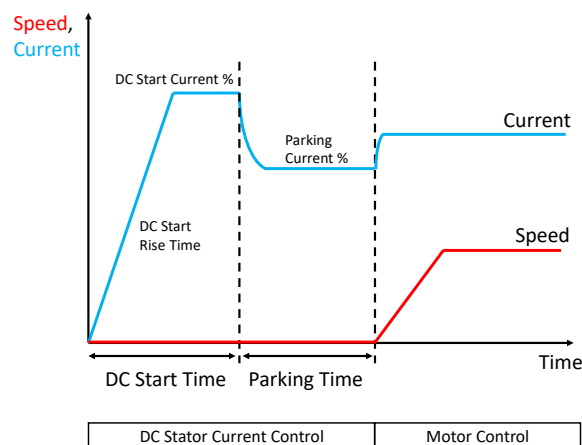

Figure 74: Operation principle of synchronous motor start.

P2.7.3.1 Sync. Motor Start Mode No. 2322

Set the synchronous motor initial position handling.

No.	Name	Description
0	Disabled	The drive will not try to obtain or set the rotor angle in the starting sequence. Recommended if angle feedback is available.
1	Rotor angle detection	Before starting operation, the drive applies a motor current set with parameter No. 2323 to detect the motor angle.
2	Rotor angle parking	The drive tries to set the rotor to the angle set with parameter No. 2326 before starting operation. The angle is set with a current defined with parameter No. 2325 , which is applied for a time defined with parameter No. 2324 .

P2.7.3.2 Sync. Motor Detection Current No. 2323
Set the rotor angle detection gain in % of the nominal motor current.

P2.7.3.3 Sync. Motor Parking Time No. 2324
Set the duration of the rotor parking.

P2.7.3.4 Sync. Motor Parking Current No. 2325
Set the rotor angle parking current in % of the nominal motor current.

P2.7.3.5 Sync. Motor Parking Angle No. 2326
Set the electrical parking angle for the rotor.

7.3.7.4 Stop Settings

The drive offers a DC stop function, which can be used for DC-hold or magnetization purposes. DC stop can only be applied at zero speed, and as the last event before entering coast state.

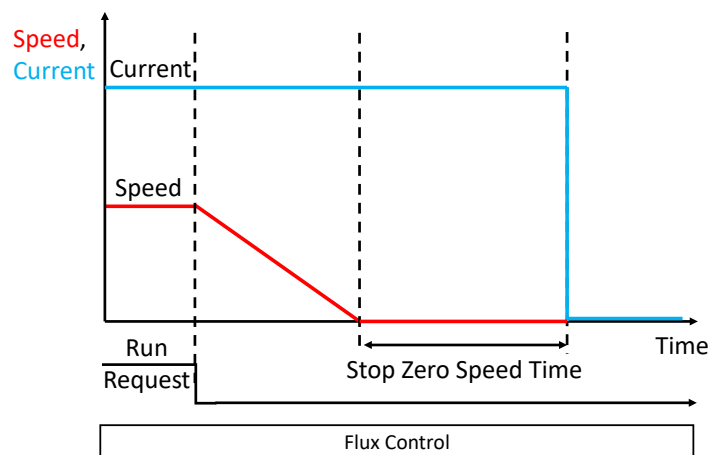

Figure 75: Operation principle of DC stop function.

P2.7.4.1 Stop Zero Speed Time No. 2331
Set the time that motor control stays active after reaching 0 speed. Value -1 means indefinitely.

P2.7.4.2 Zero-speed Detection Level No. 2339

Set the speed that is considered standstill.

P2.7.4.3 Zero-speed Detection Delay No. 2356

Set the time that the speed must be below zero-speed detection level before standstill is detected.

7.3.7.5 DC Injection

The drive offers a DC-braking function. A speed point can be configured below which a DC-braking current is applied. The DC current level and the time it is applied for during braking can also be defined. DC brake can be used consecutively with DC stop, where DC stop is applied right after DC-braking. DC stop can be used for holding or magnetization purposes. DC stop can only be applied at zero speed, and as the last event before entering coast state.

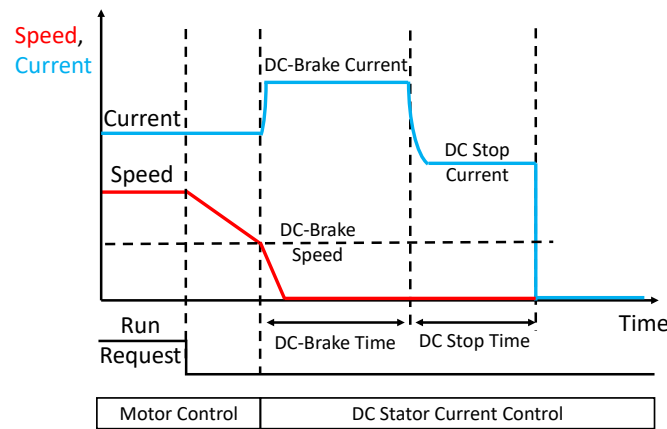

Figure 76: Operation principle of DC injection function.

P2.7.5.1 DC-brake Time No. 2267

Set the duration for a DC braking current injection.

P2.7.5.2 DC-brake Current No. 2266

Set the DC braking current in % of nominal motor current.

P2.7.5.3 DC-brake Speed No. 2268

Set the speed below which DC braking is activated.

P2.7.5.4 DC Stop Time No. 2320

Set the DC stopping injection duration. Value -1 means indefinitely.

P2.7.5.5 DC Stop Current No. 2321

Set the DC stopping current in % of nominal motor current. Applied after the drive has reached standstill.

7.3.7.6 Quick Stop

The Quick Stop function can be used as a special stop method in exceptional situations, for instance in emergencies. Parameters **No. 215** and **No. 4601** select between either a normally open or an inverted input for activating this function. Besides these inputs, a quick stop command can also be given via fieldbus.

Parameter **No. 4588** defines whether the stop should be performed by coasting or with a variety of ramps. Quick Stop specific ramping settings (parameters **No. 1129**, **No. 4590** and **No. 4613** can be defined. Quick Stop can also be configured to trigger an event, the type of which can be configured with parameter **No. 4587**. The quick stop command is a separate function from the quick stop event.

NOTICE

Once activated, Quick Stop will block starting until all active start commands are removed. In other words, a new start command is always required after a Quick Stop.

Quick Stop is not a Functional Safety feature.

P2.7.6.1 Quick Stop Input **No. 215**

Select an input terminal for activating the Quick Stop function.

No.	Name	Description
0	None (False)	No input is selected. A virtual value of FALSE is applied.
1	None (True)	No input is selected. A virtual value of TRUE is applied.
*	Fieldbus control word 1/2 digital input bits	Fieldbus CTW1 digital input bits 12-15 and CTW2 digital input bits 0-15 are presented as options.
*	Logic Digital I/O virtual terminals	Virtual digital outputs from the Logic Feature function blocks are presented as input options.
*	Available digital input terminals	A dynamically generated selection of available digital input terminals is presented as an option. The specific set depends on the type and number of I/O options installed in the system.

P2.7.6.2 Quick Stop Ramp Time **No. 1129**

Set the deceleration time for the quick stop ramp.

P2.7.6.3 Quick Stop Mode **No. 4588**

Select the stopping mode for the Quick Stop.

No.	Name	Description
0	Coast	A Quick Stop command coasts to a stop (stops modulating immediately).
1	Speed Ramp Down	A Quick Stop command forces the drive into Speed Control Mode and ramps the motor speed to zero before stopping modulation. Set a Quick Stop specific speed ramping time with parameter No. 1129 .
2	Torque Ramp Down	A Quick Stop command forces the drive into Torque Control Mode and ramps the motor torque to zero before stopping modulation. Set a Quick Stop specific torque ramp rate with parameter No. 4590 .
3	Power Ramp Down	A Quick Stop command forces the drive into Power Control Mode and ramps the motor power to zero before stopping modulation. Set a Quick Stop specific power ramp rate with parameter No. 4613 .

P2.7.6.4 Quick Stop Response **No. 4587**

Select the drive response to a Quick Stop event. Note that the drive will stop regardless of the event setting.

No.	Name	Description
0	No response	Quick stop does not trigger an event. Note that a quick stop command can still be given to stop the drive.
1	Info	The drive issues an info event and stops according to the setting of parameter No. 4588 .
3	Warning	The drive issues a warning event and stops according to the setting of parameter No. 4588 .
12	Fault	The drive issues a fault event and stops according to the setting of parameter No. 4588 .

P2.7.6.5 Quick Stop Active Output No. 5179

Select an output terminal for the Quick Stop Active indication.

No.	Name	Description
0	None	No output is selected.
*	Fieldbus status word 2 digital output bits	Fieldbus CTW2 digital output bits 0-15 are presented as options.
*	Logic Digital I/O virtual terminals	Virtual digital inputs to the Logic Feature function are presented as output options.
*	Available digital output and relay terminals	A dynamically generated selection of available digital output and relay terminals is presented as an option. The specific set depends on the type and number of I/O options installed in the system.

P2.7.6.6 Quick Stop Inverse Input No. 4601

Select an input terminal for activating the Quick Stop Inverse function.

No.	Name	Description
0	None (False)	No input is selected. A virtual value of FALSE is applied.
1	None (True)	No input is selected. A virtual value of TRUE is applied.
*	Fieldbus control word 1/2 digital input bits	Fieldbus CTW1 digital input bits 12-15 and CTW2 digital input bits 0-15 are presented as options.
*	Logic Digital I/O virtual terminals	Virtual digital outputs from the Logic Feature function blocks are presented as input options.
*	Available digital input terminals	A dynamically generated selection of available digital input terminals is presented as an option. The specific set depends on the type and number of I/O options installed in the system.

P2.7.6.7 Quick Stop Torque Ramp Rate No. 4590

Set Quick Stop torque ramp down rate in %/s.

P2.7.6.8 Quick Stop Power Ramp Rate No. 4613

Set Quick Stop power ramp down rate in %/s.

7.3.7.7 AC Brake

The AC brake improves braking without using a brake resistor. It controls the magnetization of the motor when running with a regenerative load.

This function improves the overvoltage controller function. Increasing the electrical losses in the motor allows the overvoltage controller function to increase the braking torque without exceeding the overvoltage limit.

NOTICE

Dynamic braking with the brake resistor is more efficient than the AC brake function. The AC brake function is available in VVC+ mode.

P2.7.7.1 AC Brake No. 4026

Enables the AC brake.

No.	Name	Description
0	Disabled	
1	Enabled	

P2.7.7.2 AC-brake Voltage Control Kp No. 4027

Set the scaling of the proportional gain of the AC brake controller.

P2.7.7.3 AC-brake Voltage Control Ti No. 4028

Set the scaling of the integral time of the AC brake controller.

P2.7.7.4 AC-brake Current No. 4057

Set the maximum allowed motor current in % of nominal motor current when AC brake is enabled.

7.3.7.8 Interlocking

Interlocking can be used to block the drive from starting if external systems do not allow it. This feature can be used to integrate externally controlled devices, such as motor switches, with the drive. There are two types of interlocks, Start & Run Interlocks.

Start Interlocks can be set via two separate digital inputs (parameters **No. 4713**, **No. 4714**). The drive cannot be started unless both signals are active. Start interlocks will only block the start. Removing them while the drive is running has no effect on the drive.

Run Interlocks can also be set via another set of two digital inputs (parameters **No. 4715**, **No. 4716**). Run interlocks work similarly to start interlocks, but removing either of them while the drive is running will stop the drive.

With parameter **No. 4719** interlocking can be configured to trigger an event, due to a failed start with an active interlock. Interlocks will always block the start until all locks are removed and a new start command has been given.

P2.7.8.1 Start Interlock Input 1 No. 4713

Select an input for Start Interlock 1. When active, this signal will block the start, but its deactivation will not stop the drive.

No.	Name	Description
0	None (False)	No input is selected. A virtual value of FALSE is applied.
1	None (True)	No input is selected. A virtual value of TRUE is applied.
*	Fieldbus control word 1/2 digital input bits	Fieldbus CTW1 digital input bits 12-15 and CTW2 digital input bits 0-15 will be presented as options.
*	Logic Digital I/O virtual terminals	Virtual digital outputs from the Logic Feature function blocks are presented as input options.
*	Available digital input terminals	A dynamically generated selection of available digital input terminals is presented as an option. The specific set depends on the type and number of I/O options installed in the system.

P2.7.8.2 Start Interlock Input 2 No. 4714

Select an input for Start Interlock 2. When active, this signal will block the start, but its deactivation will not stop the drive.

No.	Name	Description
0	None (False)	No input is selected. A virtual value of FALSE is applied.
1	None (True)	No input is selected. A virtual value of TRUE is applied.
*	Fieldbus control word 1/2 digital input bits	Fieldbus CTW1 digital input bits 12-15 and CTW2 digital input bits 0-15 will be presented as options.
*	Logic Digital I/O virtual terminals	Virtual digital outputs from the Logic Feature function blocks are presented as input options.
*	Available digital input terminals	A dynamically generated selection of available digital input terminals is presented as an option. The specific set depends on the type and number of I/O options installed in the system.

P2.7.8.3 Run Interlock Input 1 No. 4715

Select an input for Run Interlock 1. When active, this signal will block the Run Request in all conditions.

No.	Name	Description
0	None (False)	No input is selected. A virtual value of FALSE is applied.
1	None (True)	No input is selected. A virtual value of TRUE is applied.
*	Fieldbus control word 1/2 digital input bits	Fieldbus CTW1 digital input bits 12-15 and CTW2 digital input bits 0-15 will be presented as options.
*	Logic Digital I/O virtual terminals	Virtual digital outputs from the Logic Feature function blocks are presented as input options.
*	Available digital input terminals	A dynamically generated selection of available digital input terminals is presented as an option. The specific set depends on the type and number of I/O options installed in the system.

P2.7.8.4 Run Interlock Input 2 No. 4716

Select an input for Run Interlock 2. When active, this signal will block the Run Request in all conditions.

No.	Name	Description
0	None (False)	No input is selected. A virtual value of FALSE is applied.
1	None (True)	No input is selected. A virtual value of TRUE is applied.
*	Fieldbus control word 1/2 digital input bits	Fieldbus CTW1 digital input bits 12-15 and CTW2 digital input bits 0-15 will be presented as options.
*	Logic Digital I/O virtual terminals	Virtual digital outputs from the Logic Feature function blocks are presented as input options.
*	Available digital input terminals	A dynamically generated selection of available digital input terminals is presented as an option. The specific set depends on the type and number of I/O options installed in the system.

P2.7.8.5 Interlocking Response No. 4719

Select the response for a blocked start due to active interlocking.

No.	Name	Description
0	No response	-

No.	Name	Description
1	Info	The drive will issue an info event.
3	Warning	The drive will issue a warning event.
9	Fault, ramp to coast	The drive will issue a fault event and ramp motor speed to zero before stopping modulation.
10	Fault, coast	The drive will issue a fault event and stop modulation immediately.

P2.7.8.6 Interlocking Response Delay No. 4720

Set a delay before the response to a blocked start due to active interlocking.

7.3.8 Control Places

The P&M application features five different control places for determining how basic drive commands and references are interfaced. These control places are PC Control (MyDrive® Insight), Local Control (via control panel), Fieldbus Control, I/O Control and Advanced Control.

Selection:

There are two methods for selecting which control place is active, or in other words in command of the drive. The first is a simple parameter selection, while the second is a set of signals that can be used to force or request for a specific control place to be in command.

References:

Most of the references are control place specific. Which reference source each control place uses and how the source is scaled, among other things, can be defined. These settings are available in parameter group **2.2**.

Commands:

A control place is also a source for basic control commands (start, stop, reset, and so on). When operating for instance in I/O control, the drive cannot be started from the local or fieldbus control places. Control places do not dictate all possible commands. Note that specific features such as Inching, or Quick Stop can be used regardless of the control place and must be configured separately.

7.3.8.1 Control Place Settings

This group contains general control place settings that mainly have to do with control place selection. The following figure presents the control place selection chain diagram. The default method for choosing the control place is by using the parameter **No. 114 Control Place Selection**. It can be used to select the active control place between Local, Fieldbus, I/O and Advanced control.

Application Guide

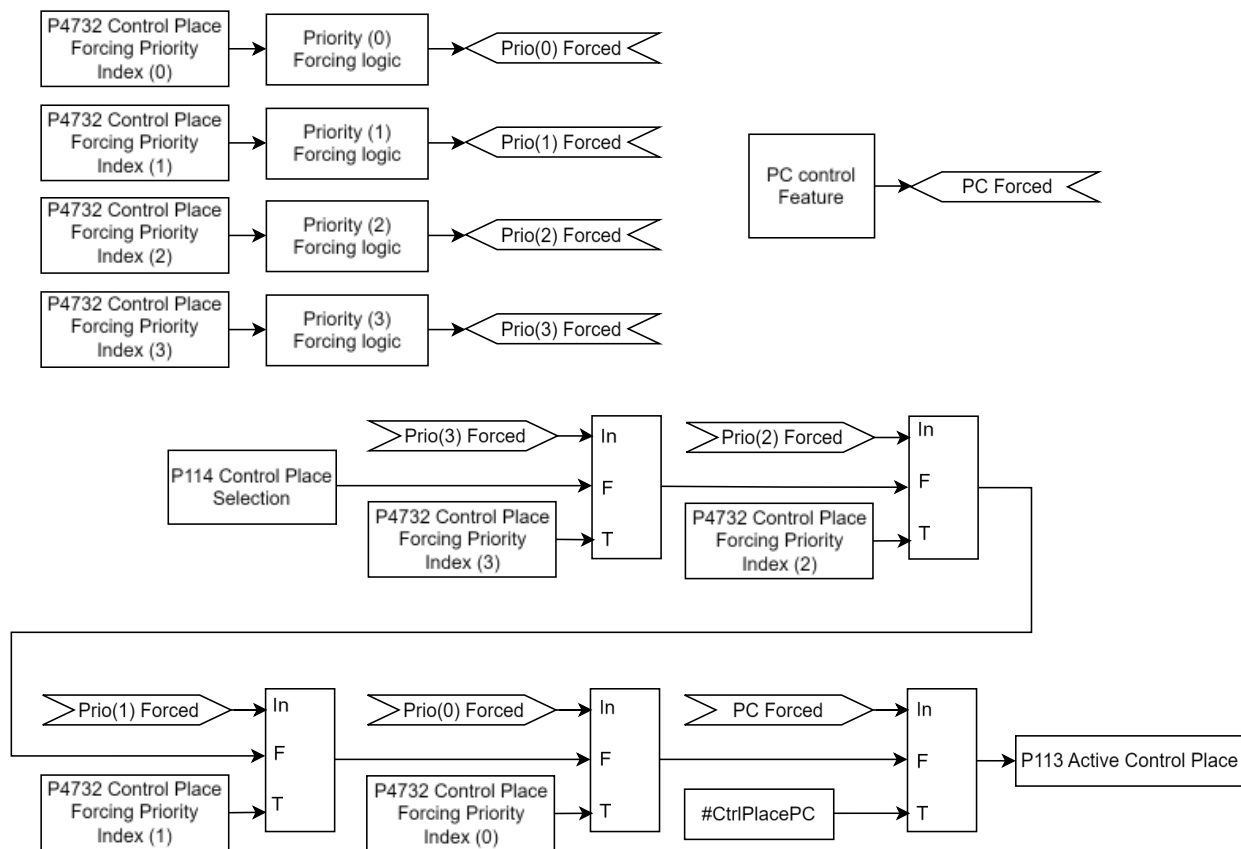

Figure 77: Control place selection chain diagram.

The second option for control place selection is to use control place forcing signals (**No. 4511, 4513, and 4721**), which will override the selection made with the parameter, and can be used to swap between different control places, for example via external push buttons or switches. The forcing signals for Fieldbus, I/O, and Advanced control can be mapped to digital inputs or fieldbus, and the Local control forcing is activated with the REM/LOC button of the control panel. In addition, the forcing signals for Fieldbus, I/O, and Advanced Control can be activated with the **FB PCD Operation Control Word (No. 4564)**. Bit 2 of the Operation Control Word is used for forcing Fieldbus Control, bit 3 for forcing I/O Control, and bit 4 for forcing Advanced Control.

The priority order for the forceable control places is configured with parameter **No. 4732**. The priority order affects the final control place selection if two or more control places are forced on simultaneously. For example: if Fieldbus is selected for highest priority with Index-0, and I/O for the next highest priority with index-1, and both control places are forced on simultaneously, fieldbus will be selected as the active control place. After Fieldbus forcing is removed the control place will fall to I/O because it has higher priority than the parameter selection.

The only control place which can take over the control from any other control place regardless of forcing inputs is the MyDrive® Insight. Control is taken by requesting it via the tool itself. By default, the drive uses the following control place priority order:

MyDrive® Insight > Local Control > Advanced > I/O > Fieldbus > Parameter Selection

Forcing can be further configured with parameter **No. 1972** which defines whether each forcing signal is treated as a state sensitive or toggled signal.

Parameter **No. 4800** can be used to define how the drive should behave when an active control place releases control. The options are to either release control immediately or only if another control place requests control.

When a control place is changed, the drive will either stop or continue operating (modulation) based on the settings defined with parameters **No. 108**, **No. 5112**, **No. 5111**, and **No. 5113** respectively for each control place.

P2.8.1.1 Control Place Selection No. 114

Select the active control place.

No.	Name	Description
0	PC control	
1	Local control	
2	Fieldbus control	
3	I/O control	
4	Advanced control	

P2.8.1.2 Force FB Control Input No. 4511

Select an input terminal for forcing the control place to Fieldbus.

No.	Name	Description
0	None (False)	No input is selected. A virtual value of FALSE is applied.
1	None (True)	No input is selected. A virtual value of TRUE is applied.
*	Fieldbus control word 1/2 digital input bits	Fieldbus CTW1 digital input bits 12-15 and CTW2 digital input bits 0-15 will be presented as options.
*	Logic Digital I/O virtual terminals	Virtual digital outputs from the Logic Feature function blocks are presented as input options.
*	Available digital input terminals	A dynamically generated selection of available digital input terminals is presented as an option. The specific set depends on the type and number of I/O options installed in the system.

P2.8.1.3 Force I/O Control Input No. 4513

Select an input terminal for forcing the control place to I/O.

No.	Name	Description
0	None (False)	No input is selected. A virtual value of FALSE is applied.
1	None (True)	No input is selected. A virtual value of TRUE is applied.
*	Fieldbus control word 1/2 digital input bits	Fieldbus CTW1 digital input bits 12-15 and CTW2 digital input bits 0-15 will be presented as options.
*	Logic Digital I/O virtual terminals	Virtual digital outputs from the Logic Feature function blocks are presented as input options.
*	Available digital input terminals	A dynamically generated selection of available digital input terminals is presented as an option. The specific set depends on the type and number of I/O options installed in the system.

P2.8.1.4 Force Advanced Control Input No. 4721

Select an input terminal for forcing the control place to advanced control.

No.	Name	Description
0	None (False)	No input is selected. A virtual value of FALSE is applied.
1	None (True)	No input is selected. A virtual value of TRUE is applied.
*	Fieldbus control word 1/2 digital input bits	Fieldbus CTW1 digital input bits 12-15 and CTW2 digital input bits 0-15 will be presented as options.
*	Logic Digital I/O virtual terminals	Virtual digital outputs from the Logic Feature function blocks are presented as input options.
*	Available digital input terminals	A dynamically generated selection of available digital input terminals is presented as an option. The specific set depends on the type and number of I/O options installed in the system.

P2.8.1.5 Control Place Forcing Mode No. 1972

Select whether each control place forcing signal is treated as a state sensitive or a toggled signal. With toggling enabled, the forcing is activated by the first rising edge and deactivated by the second rising edge of the respective forcing signals.

No.	Name			Description
0	FB: State	I/O: State	Adv: State	
1	FB: Toggle	I/O: State	Adv: State	
2	FB: State	I/O: Toggle	Adv: State	
3	FB: Toggle	I/O: Toggle	Adv: State	
4	FB: State	I/O: State	Adv: Toggle	
5	FB: Toggle	I/O: State	Adv: Toggle	
6	FB: State	I/O: Toggle	Adv: Toggle	
7	FB: Toggle	I/O: Toggle	Adv: Toggle	

P2.8.1.6 Control Place Independent Reset No. 109

Enable faults to be reset from all control places.

No.	Name	Description
0	Disabled	Reset will go through only from active control place.
1	Enabled	Reset will go through from all control places regardless it was given from the active control place or not.

P2.8.1.7 Control Place Release Mode No. 4800

Select the action after the control place is released from the forced control places, as well as from control panel or PC control. When set to "Change After Release" the control place is changed after releasing to other forced place highest in priority order, or in case no forced places are used, to the place defined with parameter Control Place Selection. When set to "Retain After Release" the control place is not changed after releasing, but only after the control place is changed by forcing or by the parameter Control Place Selection.

No.	Name	Description
0	Retain After Release	When the forcing of the currently active control place is released, a new forcing command is required from another

No.	Name	Description
1	Change After Release	control place, for the active control place to change. When the forcing of the currently active control place is released, the control place will be changed immediately.

P2.8.1.8 Control Place Forcing Priority No. 4732

Set the control place priority when using control place forcing inputs. The parameter is an array where the priority is specified in decreasing order of the array members (Index 0-4). Therefore, in case multiple control places are requested simultaneously, the selection made with Index 0 prevails on the selection made with Index 1, and so on. If a control place is not assigned any priority, its forcing signal is disabled.

Index	Name	Description
0	Highest priority control place	Select the control place with the highest priority from the following list: <ul style="list-style-type: none"> • Local control • Fieldbus • I/O • Advanced
1	2nd highest priority control place	Select the control place with the second highest priority from the following list: <ul style="list-style-type: none"> • Local control • Fieldbus • I/O • Advanced
2	3rd highest priority control place	Select the control place with the 3 rd highest priority from the following list: <ul style="list-style-type: none"> • Local control • Fieldbus • I/O • Advanced
3	Lowest priority control place	Select the control place with the lowest priority from the following list: <ul style="list-style-type: none"> • Local control • Fieldbus • I/O • Advanced

P2.8.1.9 Continue Operation in PC Control No. 105

Select whether the start request is retained when the drive is running and the control place is changed to PC control.

No.	Name	Description
0	Disabled	The drive will stop when the active control place is changed. The stop mode is defined with parameter No. 4717.
1	Enabled	The drive will continue operating through the control place transition.

P2.8.1.10 Continue Operation in Local Control No. 108

Select whether the start request is retained when the drive is running, and the control place is changed to local control.

No.	Name	Description
0	Disabled	The drive will stop when the active control place is changed. The stop mode is defined with parameter No. 4717 .
1	Enabled	The drive will continue operating through the control place transition.

P2.8.1.11 Continue Operation in Fieldbus Control No. 5112

Select whether the start request is retained when the drive is running and the control place is changed to fieldbus. Note that any active stop command or auxiliary function such as quick stop may still prohibit continuing operation. Note also that continuation is possible only if the start is requested from fieldbus before the control place is changed to it.

No.	Name	Description
0	Disabled	The drive will stop when the active control place is changed. The stop mode is defined with parameter No. 4717 .
1	Enabled	The drive will continue operating through the control place transition.

P2.8.1.12 Continue Operation in I/O Control No. 5111

Select whether the start request is retained when the drive is running and the control place is changed to I/O, while using edge-sensitive start modes. Note that any active stop command or auxiliary function such as quick stop may still prohibit continuing operation.

No.	Name	Description
0	Disabled	The drive will stop when the active control place is changed. The stop mode is defined with parameter No. 4717 .
1	Enabled	The drive will continue operating through the control place transition.

P2.8.1.13 Continue Operation in Adv. Control No. 5113

Select whether the start request is retained when the drive is running and the control place is changed to advanced control place, while using edge-sensitive start modes. Note that any active stop command or auxiliary function such as quick stop may still prohibit continuing operation.

No.	Name	Description
0	Disabled	The drive will stop when the active control place is changed. The stop mode is defined with parameter No. 4717 .
1	Enabled	The drive will continue operating through the control place transition.

7.3.8.2 Local Control

Local control, also known as panel control, can be selected by the Selection parameter or by overriding control by pressing the REM/LOC-button on the panel. When control is released from the panel, the control place will be determined by the Selection parameter or forcing signals. The drive

offers a protection feature for monitoring the connection between the drive and the panel (parameter **No. 5420**). If the connection is lost while the panel is in control of the drive, the drive will force-release the control to the next control place in line. Do note that if Local control has not been given any priority with parameter **No. 4732** the change to Local control is disabled with the REM/LOC button.

P2.8.2.1 Allow Local Control Force Stop No. 106

Select whether the control panel stop button always stops the drive, regardless of the selected control place. Pressing the stop button also places the drive in local control.

No.	Name	Description
0	Disabled	
1	Enabled	

P2.8.2.2 Local Control Mode No. 107

Select restrictions of local control by the control panel. Use this parameter to influence the amount of control anyone accessing the control panel can have on the operation of the drive.

No.	Name	Description
0	Allow Local Control	Local Control can become the active control place. Local control can both start and stop the drive.
1	Deny Local Start	Local Control can become the active control place. Local control cannot start the drive, but it can stop it.
2	Deny Local Control	Local Control cannot become the active control place.

P2.8.2.3 Local Control Stop Button Action No. 110

Select the action of the stop button in the control panel. Selecting 'Stop, Hold to Coast' will stop, and coast if the stop button is pressed for 2 s.

No.	Name	Description
0	Ramp Stop	Push the stop button to ramp stop.
1	Coast Stop	Push stop button to coast the motor.
2	Ramp Stop, Hold to Coast	Push the stop button to ramp stop. If pressed for 2 seconds, the motor will coast stop.

7.3.8.3 I/O Control

The I/O control place is designed to give basic commands (start, stop, reset, and so on) to the drive via a set of digital input signals.

P2.8.3.1 I/O Start Forward Input No. 200

Select the input source for the start forward command for when the drive operates in I/O control.

No.	Name	Description
0	None (False)	No input is selected. A virtual value of FALSE is applied.
1	None (True)	No input is selected. A virtual value of TRUE is applied.
8201	Logic Start	Logic Start virtual output from the Logic Feature is used as an input.

No.	Name	Description
*	Logic Digital I/O virtual terminals	Virtual digital outputs from the Logic Feature function blocks are presented as input options.
*	Available digital input terminals	A dynamically generated selection of available digital input terminals is presented as an option. The specific set depends on the type and number of I/O options installed in the system.

P2.8.3.2 I/O Start Backward Input **No. 210**

Select the input source for the start backward command for when the drive operates in I/O control.

No.	Name	Description
0	None (False)	No input is selected. A virtual value of FALSE is applied.
1	None (True)	No input is selected. A virtual value of TRUE is applied.
8201	Logic Start	Logic Start virtual output from the Logic Feature is used as an input.
*	Logic Digital I/O virtual terminals	Virtual digital outputs from the Logic Feature function blocks are presented as input options.
*	Available digital input terminals	A dynamically generated selection of available digital input terminals is presented as an option. The specific set depends on the type and number of I/O options installed in the system.

P2.8.3.3 I/O Ramp Stop Inverse Input **No. 201**

Select the input source for the inverted ramp stop command when the drive operates in I/O control.

No.	Name	Description
0	None (False)	No input is selected. A virtual value of FALSE is applied.
1	None (True)	No input is selected. A virtual value of TRUE is applied.
8202	Logic Stop	Logic Stop virtual output from the Logic Feature is used as an input.
*	Logic Digital I/O virtual terminals	Virtual digital outputs from the Logic Feature function blocks are presented as input options.
*	Available digital input terminals	A dynamically generated selection of available digital input terminals is presented as an option. The specific set depends on the type and number of I/O options installed in the system.

P2.8.3.4 I/O Coast Inverse Input **No. 202**

Select the input source for the inverted coast stop command when the drive operates in I/O control.

No.	Name	Description
0	None (False)	No input is selected. A virtual value of FALSE is applied.
1	None (True)	No input is selected. A virtual value of TRUE is applied.
8203	Logic Coast	Logic Coast virtual output from the Logic Feature is used as an input.
*	Logic Digital I/O virtual terminals	Virtual digital outputs from the Logic Feature function blocks are presented as input options.
*	Available digital input terminals	A dynamically generated selection of available digital input terminals is presented as an option. The specific set depends on the type and number of I/O options installed in the system.

P2.8.3.5 I/O Reverse Input No. 204

Select the input source for the reversing command for when the drive operates in I/O control.

No.	Name	Description
0	None (False)	No input is selected. A virtual value of FALSE is applied.
1	None (True)	No input is selected. A virtual value of TRUE is applied.
8204	Logic Reverse	Logic Reverse virtual output from the Logic Feature is used as an input.
*	Logic Digital I/O virtual terminals	Virtual digital outputs from the Logic Feature function blocks are presented as input options.
*	Available digital input terminals	A dynamically generated selection of available digital input terminals is presented as an option. The specific set depends on the type and number of I/O options installed in the system.

P2.8.3.6 I/O Reset Input No. 203

Select the input source for the reset command for when the drive operates in I/O control.

No.	Name	Description
0	None (False)	No input is selected. A virtual value of FALSE is applied.
1	None (True)	No input is selected. A virtual value of TRUE is applied.
8205	Logic Reset	Logic Reset virtual output from the Logic Feature is used as an input.
*	Logic Digital I/O virtual terminals	Virtual digital outputs from the Logic Feature function blocks are presented as input options.
*	Available digital input terminals	A dynamically generated selection of available digital input terminals is presented as an option. The specific set depends on the type and number of I/O options installed in the system.

P2.8.3.7 I/O Start Mode No. 214

Select whether start commands for I/O control are state, rising edge or pulse sensitive.

No.	Name	Description
0	State High Start	<p>A start is requested based on the high state of the signal.</p> <p>When the start signal is removed the drive will stop according to parameter No. 4717 Missing Start Response.</p> <p>In case the start signal is high when a fault is cleared, or a separate stop signal is removed, the drive will start running immediately.</p> <p>Any active stop signal will block the start.</p>
1	Rising Edge Start	<p>A start is requested based on the combination of the rising-edge and the high-state of the signal.</p> <p>The drive will stop according to parameter No. 4717 Missing Start Response if the signal is removed.</p> <p>The drive will not start running in case the start signal is high when a fault is cleared, or a separate stop signal is removed.</p> <p>Any active stop signal will block the start.</p>
2	High Pulse Start	A start is requested based on the rising edge of the signal.

No.	Name	Description
		<p>The drive is stopped with a rising edge of a separate stop signal.</p> <p>The drive will not start running in case the start signal is high when a fault is cleared, or a separate stop signal is removed.</p> <p>Any active stop signal will block the start.</p>

7.3.8.4 Fieldbus Control

The drive can be controlled through a fieldbus master. When fieldbus is selected as the active control place, the drive will monitor active fieldbus connections for control commands.

How the drive interprets the commands depends on the selected fieldbus profile selected with parameter **No. 1301**. The profile will determine how the fieldbus control word is interpreted and how the fieldbus status word is formed. The profile may also enforce specific control schemes for things such as the starting sequence. All available profiles are described in 2.2 Fieldbus Control Profile Descriptions.

P2.8.4.1 Fieldbus Profile No. 1301

Select the fieldbus profile. The selection affects the interpretation of the control word and status word.

No.	Name	Description
0	iC Generic Profile	The default Propulsion and Machinery application profile.
1	iC Speed Profile	An all-purpose speed control profile for iC drives
2	PROFIdrive® Application Class 1 Profile	A standard PROFIdrive® speed control profile
3	CiA402 Velocity Mode Profile	A standard EtherCAT® speed control profile

NOTICE

- 1) Setting this parameter to "iC Generic Profile" automatically updates the following parameters to following values:
 - **No. 6312 Fieldbus Speed Signal Max** to 10000
 - **No. 6313 Fieldbus Speed Signal Min** to -1000
 - **No. 6310 Fieldbus Speed Scale Max** to $2 * \text{Motor Nominal Frequency (No. 403)}$
 - **No. 6313 Fieldbus Speed Scale Min** to $(-2) * \text{Motor Nominal Frequency (No. 403)}$

- 2) Setting this parameter to "Speed Profile" automatically updates the following parameters to following values:
 - **No. 6312 Fieldbus Speed Signal Max** to 32767
 - **No. 6313 Fieldbus Speed Signal Min** to -32768
 - **No. 6310 Fieldbus Speed Scale Max** to $2 * \text{Motor Nominal Frequency (No. 403)}$
 - **No. 6313 Fieldbus Speed Scale Min** to $(-2) * \text{Motor Nominal Frequency (No. 403)}$

- 3) Setting this parameter to "PROFIdrive® Standard Telegram 1" automatically updates the following parameters to following values:
 - **No. 6312 Fieldbus Speed Signal Max** to 32767
 - **No. 6313 Fieldbus Speed Signal Min** to -32768
 - **No. 6310 Fieldbus Speed Scale Max** to $2 * \text{Motor Nominal Frequency (No. 403)}$
 - **No. 6313 Fieldbus Speed Scale Min** to $(-2) * \text{Motor Nominal Frequency (No. 403)}$

 - **No. 5251 Limit Supervision Signal Number 1** to "Motor Shaft Speed"
 - **No. 5252 Limit Supervision 1 Type** to "Supervise High Limit"
 - **No. 5253 Limit Supervision 1 Threshold** to 100.00 rpm
 - **No. 5255 Limit Supervision 1 Hysteresis** to 0.00 %
 - **No. 5250 Limit Supervision Response 1** to "No response"

7.3.8.5 Advanced control

This control place can be configured similarly as the I/O control place; however, its command signals can be formed by combining signals from both fieldbus and digital inputs. Various combination logics can be assigned for each command separately. Single sources can be selected also, if combination of signals is not needed, but another control place needs to be dedicated to I/O or fieldbus signals.

It should be noted that the fieldbus commands that can be assigned to advanced control place follow all the rules dedicated to which ever fieldbus profile is currently selected. For instance, if a profile requires for a specific start sequence, this sequence needs to be followed to activate the fieldbus start command within advanced control place.

P2.8.5.1 Advanced Start Forward Input

No. 4722

Select inputs for starting in the forward direction when operating in advanced control. Two sources are available (Index 0 and Index 1), which can be combined into 1 command with parameter **No. 1933**.

No.	Name	Description
0	None (False)	No input is selected. A virtual value of FALSE is applied.
1	None (True)	No input is selected. A virtual value of TRUE is applied.
2	Fieldbus Start	Fieldbus control word's start bit is used for the start command.

No.	Name	Description
		Specific bit depends on the fieldbus profile (parameter No. 1301).
8201	Logic Start	Logic Start virtual output from the Logic Feature is used as an input.
*	Fieldbus control word 1/2 digital input bits	Fieldbus CTW1 digital input bits 12-15 and CTW2 digital input bits 0-15 will be presented as options.
*	Logic Digital I/O virtual terminals	Virtual digital outputs from the Logic Feature function blocks are presented as input options.
*	Available digital input terminals	A dynamically generated selection of available digital input terminals is presented as an option. The specific set depends on the type and number of I/O options installed in the system.

P2.8.5.2 Advanced Start Forward Logic **No. 1933**

Select the combination logic for the start command of advanced control.

No.	Name	Description
0	Source 1	The command is active when Source 1 (index 0) is active.
1	Source 2	The command is active when Source 2 (index 1) is active.
2	AND	The command is active when both sources are active.
3	OR	The command is active when either or both sources are active.
4	NAND	The command is active when only one or neither of the two sources is active.
5	NOR	The command is active when neither of the two sources are active.
6	XOR	The command is active when only one of the sources are active.
7	XNOR	The command is active when neither or both sources are active.

P2.8.5.3 Advanced Start Backward Input **No. 4725**

Select inputs for starting in the backward direction when operating in advanced control. Two sources are available (Index 0 and Index 1), which can be combined into 1 command with parameter **No. 1934**.

No.	Name	Description
0	None (False)	No input is selected. A virtual value of FALSE is applied.
1	None (True)	No input is selected. A virtual value of TRUE is applied.
2	Fieldbus Start	Fieldbus control word's start bit is used for the reverse start command. Specific bit depends on the fieldbus profile (parameter No. 1301).
8201	Logic Start	Logic Start virtual output from the Logic Feature is used as an input.
*	Fieldbus control word 1/2 digital input bits	Fieldbus CTW1 digital input bits 12-15 and CTW2 digital input bits 0-15 will be presented as options.
*	Logic Digital I/O virtual terminals	Virtual digital outputs from the Logic Feature function blocks are presented as input options.
*	Available digital input terminals	A dynamically generated selection of available digital input terminals is presented as an option. The specific set depends on the type and number of I/O options installed in the system.

P2.8.5.4 Advanced Start Backward Logic No. 1934

Select the combination logic for the start-backward command of advanced control.

No.	Name	Description
0	Source 1	The command is active when Source 1 (index 0) is active.
1	Source 2	The command is active when Source 2 (index 1) is active.
2	AND	The command is active when both sources are active.
3	OR	The command is active when either or both sources are active.
4	NAND	The command is active when only one or neither of the two sources is active.
5	NOR	The command is active when neither of the two sources are active.
6	XOR	The command is active when only one of the sources are active.
7	XNOR	The command is active when neither or both sources are active.

P2.8.5.5 Adv. Ramp Stop Inverse Input No. 4723

Select inputs for inverted ramp stopping when operating in advanced control. Two sources are available (Index 0 and Index 1), which can be combined into 1 command with parameter **No. 1935**.

No.	Name	Description
0	None (False)	No input is selected. A virtual value of FALSE is applied.
1	None (True)	No input is selected. A virtual value of TRUE is applied.
2	Fieldbus stop	Fieldbus control word's Ramp Stop bit is used for the inverse ramp stop command. Specific bit depends on the fieldbus profile (parameter No. 1301).
8202	Logic Stop	Logic Stop virtual output from the Logic Feature is used as an input.
*	Fieldbus control word 1/2 digital input bits	Fieldbus CTW1 digital input bits 12-15 and CTW2 digital input bits 0-15 will be presented as options.
*	Logic Digital I/O virtual terminals	Virtual digital outputs from the Logic Feature function blocks are presented as input options.
*	Available digital input terminals	A dynamically generated selection of available digital input terminals is presented as an option. The specific set depends on the type and number of I/O options installed in the system.

P2.8.5.6 Adv. Ramp Stop Inverse Logic No. 1935

Select the combination logic for the inverted ramp stop command of advanced control.

No.	Name	Description
0	Source 1	The command is active when Source 1 (index 0) is inactive.
1	Source 2	The command is active when Source 2 (index 1) is inactive.
2	AND	The command is active when both sources are inactive.
3	OR	The command is active when either or both sources are inactive.
4	NAND	The command is active when only one or neither of the two sources is inactive.
5	NOR	The command is active when neither of the two sources are inactive.
6	XOR	The command is active when only one of the sources are inactive.
7	XNOR	The command is active when neither or both sources are inactive.

P2.8.5.7 Advanced Coast Inverse Input No. 4724

Select inputs for the coast when operating in advanced control. False means the drive is coasted. Two sources are available (Index 0 and Index 1), which can be combined into 1 command with parameter **No. 1936**.

No.	Name	Description
0	None (False)	No input is selected. A virtual value of FALSE is applied.
1	None (True)	No input is selected. A virtual value of TRUE is applied.
2	Fieldbus Coast	Fieldbus control word's coast bit is used for the inverse coast command. Specific bit depends on the fieldbus profile (parameter No. 1301).
8203	Logic Coast	Logic Coast virtual output from the Logic Feature is used as an input.
*	Fieldbus control word 1/2 digital input bits	Fieldbus CTW1 digital input bits 12-15 and CTW2 digital input bits 0-15 will be presented as options.
*	Logic Digital I/O virtual terminals	Virtual digital outputs from the Logic Feature function blocks are presented as input options.
*	Available digital input terminals	A dynamically generated selection of available digital input terminals is presented as an option. The specific set depends on the type and number of I/O options installed in the system.

P2.8.5.8 Advanced Coast Inverse Logic No. 1936

Select the combination logic for the inverted coast command of advanced control.

No.	Name	Description
0	Source 1	The command is active when Source 1 (index 0) is inactive.
1	Source 2	The command is active when Source 2 (index 1) is inactive.
2	AND	The command is active when both sources are inactive.
3	OR	The command is active when either or both sources are inactive.
4	NAND	The command is active when only one or neither of the two sources is inactive.
5	NOR	The command is active when neither of the two sources are inactive.
6	XOR	The command is active when only one of the sources are inactive.
7	XNOR	The command is active when neither or both sources are inactive.

P2.8.5.9 Advanced Reversing Input No. 4730

Select inputs for inverting the reference signal when operating in advanced control. The reverse command does not provide a start signal. Two sources are available (Index 0 and Index 1), which can be combined into 1 command with parameter **No. 1937**.

No.	Name	Description
0	None (False)	No input is selected. A virtual value of FALSE is applied.
1	None (True)	No input is selected. A virtual value of TRUE is applied.
2	Fieldbus Reverse	Fieldbus control word's reverse bit is used for the reverse command. Specific bit depends on the fieldbus profile (parameter No. 1301).
8204	Logic Reverse	Logic Reverse virtual output from the Logic Feature is used as an input.

No.	Name	Description
*	Fieldbus control word 1/2 digital input bits	Fieldbus CTW1 digital input bits 12-15 and CTW2 digital input bits 0-15 will be presented as options.
*	Logic Digital I/O virtual terminals	Virtual digital outputs from the Logic Feature function blocks are presented as input options.
*	Available digital input terminals	A dynamically generated selection of available digital input terminals is presented as an option. The specific set depends on the type and number of I/O options installed in the system.

P2.8.5.10 Advanced Reverse Logic No. 1937

Select the combination logic for the reverse command of advanced control.

No.	Name	Description
0	Source 1	The command is active when Source 1 (index 0) is active.
1	Source 2	The command is active when Source 2 (index 1) is active.
2	AND	The command is active when both sources are active.
3	OR	The command is active when either or both sources are active.
4	NAND	The command is active when only one or neither of the two sources is active.
5	NOR	The command is active when neither of the two sources are active.
6	XOR	The command is active when only one of the sources are active.
7	XNOR	The command is active when neither or both sources are active.

P2.8.5.11 Advanced Reset Input No. 4731

Select inputs for resetting faults when operating in advanced control. Two sources are available (Index 0 and Index 1), which can be combined into 1 command. The sources work in parallel with an OR-logic.

No.	Name	Description
0	None (False)	No input is selected. A virtual value of FALSE is applied.
1	None (True)	No input is selected. A virtual value of TRUE is applied.
2	Fieldbus Reset	Fieldbus control word's reset bit is used for the reset command. Specific bit depends on the fieldbus profile (parameter No. 1301).
8205	Logic Reset	Logic Reset virtual output from the Logic Feature is used as an input.
*	Fieldbus control word 1/2 digital input bits	Fieldbus CTW1 digital input bits 12-15 and CTW2 digital input bits 0-15 will be presented as options.
*	Logic Digital I/O virtual terminals	Virtual digital outputs from the Logic Feature function blocks are presented as input options.
*	Available digital input terminals	A dynamically generated selection of available digital input terminals is presented as an option. The specific set depends on the type and number of I/O options installed in the system.

P2.8.5.12 Advanced Start Mode No. 4726

Select the starting logic for advanced control.

No.	Name	Description
0	State High Start	<p>A start is requested based on the high state of the signal.</p> <p>When the start signal is removed the drive will stop according to parameter No. 4717 Missing Start Response.</p> <p>In case the start signal is high when a fault is cleared, or a separate stop signal is removed, the drive will start running immediately.</p> <p>Any active stop signal will block the start.</p>
1	Rising Edge Start	<p>A start is requested based on the combination of the rising-edge and the high-state of the signal.</p> <p>The drive will stop according to parameter No. 4717 Missing Start Response if the signal is removed.</p> <p>The drive will not start running in case the start signal is high when a fault is cleared, or a separate stop signal is removed.</p> <p>Any active stop signal will block the start.</p>
2	High Pulse Start	<p>A start is requested based on the rising edge of the signal.</p> <p>The drive is stopped with a rising edge of a separate stop signal.</p> <p>The drive will not start running in case the start signal is high when a fault is cleared, or a separate stop signal is removed.</p> <p>Any active stop signal will block the start.</p>

P2.8.5.13 Fieldbus CTW Feature Bits No. 4627

Enables non-control-place-dependent control word functions to be used in advanced control place. These functions include Quick Stop, Inching, Ramp Selection and so on and depend on the selected control profile (parameter **No. 1301**).

No.	Name	Description
0	Disabled	
1	Enabled	

7.3.9 Motor Control

This group contains settings for adjusting various motor control functions.

7.3.9.1 General Settings

P2.9.1.1 AMA Mode No. 420

Select the Automatic Motor Adaptation (AMA) mode.

No.	Name	Description
0	Off	AMA is disabled.
3	Motor Data - Standstill	The next start command initiates measurement of the motor data. AMA is run without rotating the motor.
4	Reduced Motor Data (Rs) - Standstill	The next start command initiates measurement of the motor stator resistance - Rs. AMA is run without motor rotation.

NOTICE

- The AMA must be run on a cold motor. Note that also running the AMA multiple times will also increase the motor temperature.
- The AMA needs to be conducted with the motor at standstill. Avoid generating external torque during AMA.
- The AMA cannot run with a sine-wave filter connected. Uncoupling the load from the motor isn't needed.
- The duration of the AMA depends on the power rating of the motor.
- The AMA calculations depend on the motor nameplate values. Define these in group **G2.1** before running the AMA.
- Changing the nameplate data will also modify the motor identification data in the groups **G2.9.2** or **G2.9.3**, depending on the motor type. It is recommended to run the AMA after changing the nameplate data.
- The parameter automatically switches back to Off after the AMA has been performed.

P2.9.1.2 Motor Control Principle

No. 2503

Select the motor control principle.

No.	Name	Description
0	U/f Control	U/f control is used for less demanding applications without slip compensation, where motor data is typically unknown. U/f can operate all motor types in open-loop speed control only. It is most suitable for asynchronous motor operation. The Volts-per-Hertz curve can be defined with parameters G2.9.4 . Only usable with the Speed Control Mode.
1	VVC+ Control	VVC+ is a medium performance motor control principle. Enables slip compensation. Does not require detailed motor data (G2.9.2 or G2.9.3). VVC+ support all motor types. It offers closed-loop speed control for asynchronous motors, and open-loop speed control for other motor types. Only usable with the Speed Control Mode.
2	FVC+ Control	FVC+ control provides high performance motor control. It supports all motor types. It can be configured to run Speed, Torque or Power control. Flux control can run with or without resolver/encoder feedback (open-loop or closed-loop speed control).

No.	Name	Description
		It requires accurate motor data (G2.9.2 or G2.9.3). Running Automatic Motor Adaption prior to Flux control is highly recommended. Mandatory for Torque and Power Control Modes.

P2.9.1.3 Breakaway Current Boost No. 2930

Enables the breakaway current boost, which temporarily allows a higher starting current.

No.	Name	Description
0	Disabled	
1	Enabled	

P2.9.1.4 Number of Pole Pairs No. 406

Set the number of pole pairs. For example, a 4-pole motor is set as 2 pole pairs. Note that the drive automatically estimates the value of this parameter when the motor nameplate values are set.

P2.9.1.5 Motor Cable Length No. 425

Set the motor cable length.

P2.9.1.6 Maximum Motor Voltage No. 5433

Set the maximum output voltage applied to the motor. This can be used to avoid a field-weakening operation when running at speeds above the nominal motor speed, when the drive is supplied with a voltage higher than the nominal motor voltage.

P2.9.1.7 Motor Voltage Limitation Mode No. 4620

Motor voltage limitation mode selection. The limitation is performed based on the selected DC-link voltage statistic.

No.	Name	Description
0	Average DC-link voltage	
1	Minimum DC-link voltage	

7.3.9.2 Induction Motor

An asynchronous induction motor can be modelled with an equivalent circuit as presented in the following figure.

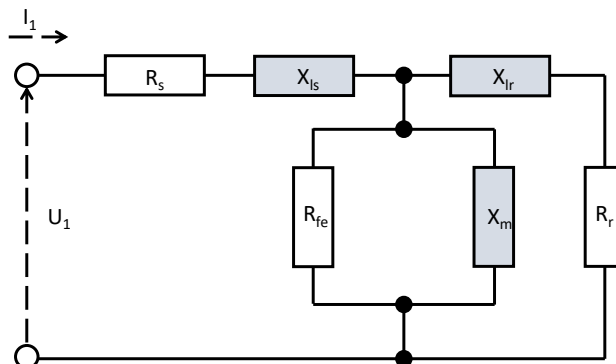

Figure 78: Equivalent circuit of an induction motor.

The key variables of this circuit are presented in this groups as parameters for better identification of the motor. These parameters can be automatically set by running the AMA successfully. Use parameters **No. 443-452** to define a saturation curve for the magnetizing reactance.

P2.9.2.1 Stator Resistance R_s No. 408

Set the motor stator resistance. Overwritten by AMA.

P2.9.2.2 Rotor Resistance R_r No. 409

Set the motor rotor resistance. Overwritten by AMA.

P2.9.2.3 Iron Loss Resistance R_{fe} No. 413

Set the motor iron-loss equivalent resistance.

P2.9.2.4 Stator Leakage Reactance X_{ls} No. 440

Set the motor stator leakage reactance. Overwritten by AMA.

P2.9.2.5 Rotor Leakage Reactance X_{lr} No. 441

Set the motor rotor leakage reactance. Overwritten by AMA.

P2.9.2.6 Magnetizing Reactance Xm No. 442

Set the motor magnetizing reactance. Overwritten by AMA.

P2.9.2.7 Magnetizing Reactance Saturation Point 1 Current No. 443

Set the magnetizing current corresponding to magnetizing reactance saturation point 1. Overwritten by AMA.

P2.9.2.8 Magnetizing Reactance Saturation Point 2 Current No. 444

Set the magnetizing current corresponding to magnetizing reactance saturation point 2. Overwritten by AMA.

P2.9.2.9 Magnetizing Reactance Saturation Point 3 Current No. 445

Set the magnetizing current corresponding to magnetizing reactance saturation point 3. Overwritten by AMA.

P2.9.2.10 Magnetizing Reactance Saturation Point 4 Current No. 446

Set the magnetizing current corresponding to magnetizing reactance saturation point 4. Overwritten by AMA.

P2.9.2.11 Magnetizing Reactance Saturation Point 5 Current No. 447

Set the magnetizing current corresponding to magnetizing reactance saturation point 5. Overwritten by AMA.

P2.9.2.12 Magnetizing Reactance Saturation Point 1 No. 448

Set the motor magnetizing reactance saturation point 1. Overwritten by AMA. If set to zero, the drive uses the magnetization reactance from parameter **No. 442**.

P2.9.2.13 Magnetizing Reactance Saturation Point 2 No. 449

Set the motor magnetizing reactance saturation point 2. Overwritten by AMA. If set to zero, the drive uses the magnetization reactance from parameter **No. 442**.

P2.9.2.14 Magnetizing Reactance Saturation Point 3 No. 450

Set the motor magnetizing reactance saturation point 3. Overwritten by AMA. If set to zero, the drive uses the magnetization reactance from parameter **No. 442**.

P2.9.2.15 Magnetizing Reactance Saturation Point 4 No. 451

Set the motor magnetizing reactance saturation point 4. Overwritten by AMA. If set to zero, the drive uses the magnetization reactance from parameter **No. 442**.

P2.9.2.16 Magnetizing Reactance Saturation Point 5 No. 452

Set the motor magnetizing reactance saturation point 5. Overwritten by AMA. If set to zero, the drive uses the magnetization reactance from parameter **No. 442**.

7.3.9.3 Permanent Magnet Motor

A permanent magnet motor can be characterized with its direct (d) and quadrature (q) axis inductances and saturation inductances in the d-q vector space. The parameters in this group provide the possibility to define these characteristics to better identify the motor. These parameters can also be automatically obtained by running the AMA successfully.

P2.9.3.1 Back EMF No. 415

Set the stator nominal induced voltage (back-EMF voltage) when running at 1000 RPM (line-to-line RMS). Overwritten by AMA.

P2.9.3.2 Stator Resistance Rs No. 408

Set the motor stator resistance. Overwritten by AMA.

P2.9.3.3 d-axis Inductance Ld No. 417

Set the motor non-saturated d-axis inductance. Overwritten by AMA.

P2.9.3.4 d-axis Inductance LdSat No. 418

Set the motor saturated d-axis inductance. Overwritten by AMA.

P2.9.3.5 Ld Saturation Point No. 426

Set the point (in % of nominal motor current) at which the Ld inductance saturates (average of non-saturated and saturated). Overwritten by AMA.

P2.9.3.6 q-axis Inductance Lq No. 427

Set the motor non-saturated q-axis inductance. Overwritten by AMA.

P2.9.3.7 q-axis Inductance LqSat No. 422

Set the motor saturated q-axis inductance. Overwritten by AMA.

P2.9.3.8 Lq Saturation Point No. 424

Set the point (in % of nominal motor current) at which the Lq inductance saturates (average of non-saturated and saturated). Overwritten by AMA.

P2.9.3.9 PMM Back EMF Based Speed Limit No. 1822

Enable speed limit for permanent magnet motors which ensures that rectified back EMF doesn't exceed overvoltage trip in case of a coast stop.

No.	Name	Description
0	Disabled	
1	Enabled	

P2.9.3.10 Feedback Angle Offset No. 9017

Set the offset between permanent magnet (direct axis) angle and absolute feedback angle in the electrical domain. The offset value is summed with the feedback angle to attain the permanent magnet angle used in the control. Its correct setting is important when running FVC+ with synchronous motors in closed loop. Overwritten by the AMA.

7.3.9.4 U/f Settings

The parameters in this group configure the voltage-frequency curve for defining how motor control behaves in the U/f Control mode. Five curve points can be defined with voltage-frequency parameter pairs.

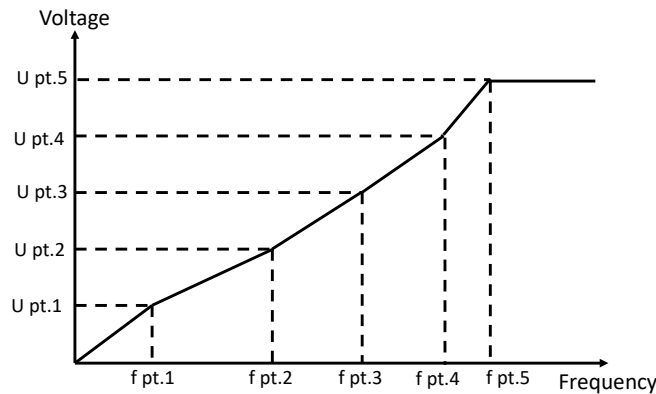

Figure 79: Example of a voltage-frequency curve in U/f control.

P2.9.4.1 Voltage Point 0 No. 2600

Set the U/f curve voltage point 0.

P2.9.4.2 Voltage Point 1 No. 2601

Set the U/f curve voltage point 1.

P2.9.4.3 Voltage Point 2 No. 2602

Set the U/f curve voltage point 2.

P2.9.4.4 Voltage Point 3 No. 2603

Set the U/f curve voltage point 3.

P2.9.4.5 Voltage Point 4 No. 2604

Set the U/f curve voltage point 4.

P2.9.4.6 Voltage Point 5 No. 2605

Set the U/f curve voltage point 5.

P2.9.4.7 Frequency Point 0 No. 2610

Set the U/f curve frequency point 0.

P2.9.4.8 Frequency Point 1 No. 2611

Set the U/f curve frequency point 1.

P2.9.4.9 Frequency Point 2 No. 2612

Set the U/f curve frequency point 2.

P2.9.4.10 Frequency Point 3 No. 2613

Set the U/f curve frequency point 3.

P2.9.4.11 Frequency Point 4 No. 2614

Set the U/f curve frequency point 4.

P2.9.4.12 Frequency Point 5 No. 2615

Set the U/f curve frequency point 5.

7.3.9.5 FVC+ Settings

The Flux vector control plus principle is an advanced motor control principle that enables several different motor control features that can be configured within this group.

P2.9.5.1 Continuous Rs Estimation **No. 428**

Enables Rs estimation while running, to compensate for changing operating conditions.

No.	Name	Description
0	Disabled	
1	Enabled	

P2.9.5.2 Current Controller Kp **No. 8021**

Set the scaling of the current controller nominal proportional gain.

P2.9.5.3 Current Controller Ti **No. 8022**

Set the scaling of the current controller nominal integral time.

P2.9.5.4 Current Controller Band Stop Frequency **No. 8023**

Set the band stop filter frequency for current control. 0 = Disabled.

P2.9.5.5 Low-speed Mode **No. 2816**

Select the motor control mode used at low speeds. The definition of low-speed depends on the selected mode.

No.	Name	Description
0	Selected motor control	No low-speed specific control is applied.
1	Force current mode (I/f Control)	Current-frequency control is used at low-speeds. This mode is activated if speed is below what is defined with parameter No. 2837 .
2	HF Injection	High Frequency Injection is used at low-speeds. This mode is activated if speed is below 10-30 % of the motor nominal speed.
3	Minimum Current Mode	Minimum current is used at low-speeds. This mode is activated if speed is below what is defined with parameter No. 2838 . The current that is applied at low-speeds is defined with parameter No. 2837 .
4	Saliency Tracking	Saliency tracking is used at low-speeds. This mode is activated if speed is below what is defined with parameter No. 2838 .

P2.9.5.6 I/f Control Current Reference **No. 2817**

Set the I/f control current reference in % of nominal motor current.

P2.9.5.7 I/f Control Speed Threshold **No. 2818**

Set the speed below which the I/f control is used.

P2.9.5.8 Low Speed Minimum Current No. 2837

Set the low-speed minimum current reference in % of nominal motor current.

P2.9.5.9 Minimum Current Speed Threshold No. 2838

Set the speed below which the minimum current control is used.

P2.9.5.10 Flux Control Feedback No. 2502

Selects the feedback mode for the control of flux in the motor control loop. In open loop the feedback is a calculated value, and in closed loop it is provided by an actual feedback device (encoder or resolver). A single feedback device is supported and is advised to be inserted in option slot 101.

No.	Name	Description
0	Open loop	Flux control uses a calculated estimation of the motor speed and angle.
1	Closed loop with Feedback Device 1	Flux control uses motor speed and angle measurement obtained from the feedback option's channel 1.
2	Closed loop with Feedback Device 2	Flux control uses motor speed and angle measurement obtained from the feedback option's channel 2.

P2.9.5.11 Relative HF Injection Voltage Gain No. 2821

Set the voltage gain for HF injection relative to the recommended voltage.

P2.9.5.12 Relative HF Inject Bandwidth No. 2826

Set the bandwidth for HF injection relative to the recommended bandwidth.

P2.9.5.13 HF Injection Angle Comp. Gain No. 2822

Set the HF injection angle error compensation gain in degrees per nominal load torque.

P2.9.5.14 HF Injection Angle Comp. Offset No. 2824

Set the HF injection angle error compensation offset in degrees.

P2.9.5.15 HF Injection Frequency No. 2823

Set the HF injection frequency. Setting 0 is equal to automatic setting of injection frequency.

P2.9.5.16 Id/Iq Reference Ratio No. 1219

Set the synchronous motor Id/Iq current reference ratio in %. It is used instead of the default MTPA, if it is set to be different from 0.

P2.9.5.17 Torque Estimation Bandwidth No. 4612

Set scaling factor for torque estimation correction bandwidth. 100% = default tuning, 0% = disable. Applies only to permanent magnet motors.

7.3.9.6 VVC+ & U/f Settings

This group contains parameters for configuring motor control features that are relevant for the Voltage Vector Control Plus and U/f Control principles.

P2.9.6.1 Slip Compensation No. 2804

Set the slip compensation in % of nominal motor slip.

P2.9.6.2 Slip Compensation Tc No. 2805

Set the slip compensation time constant.

P2.9.6.3 High-speed Load Comp. No. 2803

Set the high-speed load compensation in % of the motor voltage drop.

P2.9.6.4 Low-speed Load Comp. No. 2802

Set the low-speed load compensation in % of the motor voltage drop.

P2.9.6.5 Res. Damp. Gain No. 2806

Set the resonance damping gain in % of nominal slip for induction motors, and 0.1 times the nominal frequency for permanent magnet motors.

P2.9.6.6 Res. Damp. High Pass Tc No. 2807

Set the resonance damping high-pass time constant.

P2.9.6.7 Res. Damp Low Pass Tc No. 2808

Set the resonance damping low-pass time constant.

P2.9.6.8 Load Compensation Tc No. 8017

Load compensation time constant for induction motors in VVC+ control.

P2.9.6.9 Res. Damp. High Pass Tc (SM) No. 2819

Set time constant of resonance damping for VVC+ control of synchronous motors (SM).

7.3.9.7 Load Settings

The following group contains settings for defining details related to the motor load. Defining these settings can assist with more precise and optimized control of the load.

7.3.9.7.1 Inertia**P2.9.7.1.1 Inertia Estimation Mode No. 668**

Set the mode for the inertia estimation. The recommended setting for parameter this parameter depends on the torque characteristic configured with parameter **No. 2809**.

No.	Name	Description
0	Off	-
1	Without load profile	Next start command initiates the estimation. Use when parameter No. 2809 is set to "Constant Torque".
2	With load profile	Next start command initiates the estimation. Use when parameter No. 2809 is set to "Variable Torque".

NOTICE

After setting this parameter to something other than *Off*, the next start command will initiate the Inertia Estimation.

P2.9.7.1.2 Inertia Estimation Timeout No. 669

Set the time after which an event message will be generated if inertia estimation cannot be finalized.

P2.9.7.1.3 System Inertia No. 667

Set the system inertia.

7.3.9.7.2 Torque & AEO

P2.9.7.2.1 Torque Characteristic No. 2809

Select the torque characteristics matching the application needs.

No.	Name	Description
0	Constant torque (CT)	Recommended for applications where high load torque is expected in all (speed) operating points.
1	Variable torque (VT)	Recommended for applications with a quadratic load, such as fans and centrifugal pumps.
2	Automatic Energy Optimization (AEO)	Motor magnetization is adapted to the current load. This functionality optimizes energy efficiency but reduces dynamics to torque changes.

P2.9.7.2.2 AEO Minimum Speed No. 2810

Set the speed above which Automatic Energy Optimization (AEO) is active.

P2.9.7.2.3 AEO Minimum Magnetization No. 2811

Set the minimum magnetization current used by Automatic Energy Optimization (AEO).

P2.9.7.2.4 Variable Torque Zero Speed Magnetization No. 8020

Set the magnetization current level at 0 speed. Used in variable torque (VT) setting.

7.3.10 Speed Control

This group contains parameters for fine-tuning the speed control of the motor.

7.3.10.1 Speed Controller

7.3.10.1.1 Basic Settings

P2.10.1.1.1 Speed Controller Type No. 5005

Select the speed controller type.

No.	Name	Description
0	P-Controller	
1	PI-Controller	

P2.10.1.1.2 Speed Controller Kp FVC+ No. 4020

Set the proportional gain of the speed controller. This setting applies only if the control principle is FVC+.

P2.10.1.1.3 Speed Controller Ti FVC+ No. 4021

Set the integration time of the speed controller. This setting applies only if the control principle is FVC+.

P2.10.1.1.4 Acceleration Feedforward Gain No. 4022

Set the acceleration feedforward gain. It bypasses the speed controller by adding torque reference based on requested acceleration and system inertia. Improves tracking of speed reference changes.

P2.10.1.1.5 Speed Control Loop Type No. 4038

Select the loop type for the speed controller. The loop can be open, closed or influenced by the feedback mode of the flux control loop.

No.	Name	Description
3	Same As Flux Control Feedback	The loop type follows the setting of parameter Flux Control Feedback Mode (No. 2502) .

P2.10.1.1.6 Speed Feedback Filter Tc No. 4544

Set the speed feedback filter time constant (when the speed is controlled with speed sensor).

7.3.10.1.2 Advanced Settings

P2.10.1.2.1 Virtual Friction Gain No. 4549

Set the virtual friction gain, adding friction to the speed control loop to increase damping and stability. It is automatically adjusted when the system inertia is changed and parameter **Speed Controller Auto Tuning (No. 4546)** is enabled.

P2.10.1.2.2 Zero-speed Damping Gain No. 5434

Set the zero-speed damping gain. It dampens speed fluctuations when the speed reference is 0.

7.3.10.2 Load Drooping

Load drooping allows the configuring of a speed droop as a function of the motor load. Drooping is used for example to balance load sharing when mechanically coupling several motors to the same load. The drooping can be set to static or dynamic (parameter **No. 670**). With static drooping the drooping is directly defined with parameter **No. 671**.

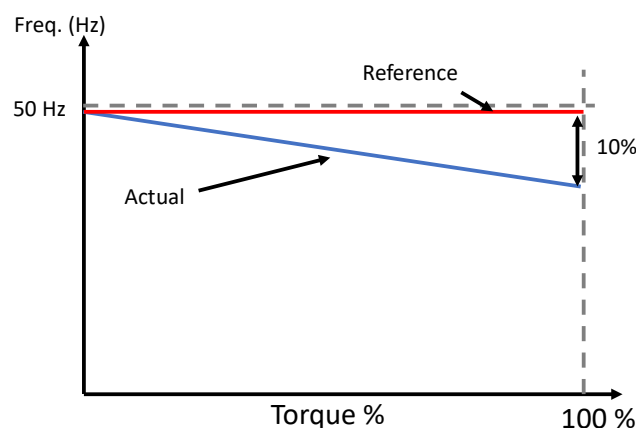

Figure 80: Example of static load drooping.

With dynamic drooping the same parameter provides the base value for drooping, but the actual value can change depending on the load. Increased load will increase drooping and vice versa.

Additional filtering parameters are also provided for tuning dynamic drooping (parameters **No. 673** and **No. 673**).

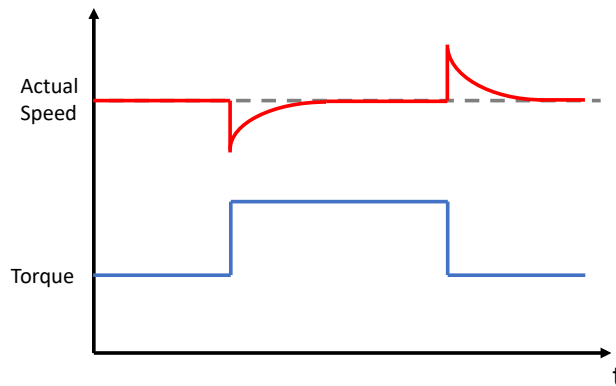

Figure 81: Example of dynamic load drooping.

A drooping removal feature is also provided. The drooping removal reduces the amount of drooping relative to decreasing motor speed. This can be used to steadily reduce drooping when nearing zero speed, where some applications require all load sharing motors to have precisely a zero-speed reference.

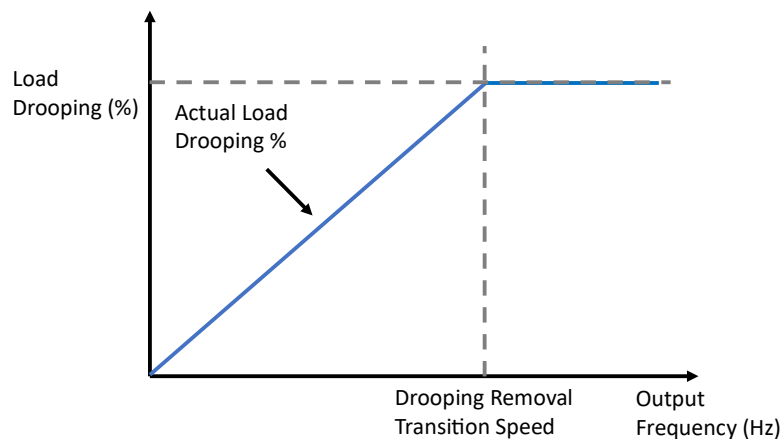

Figure 82: Drooping removal function.

P2.10.2.1 Load Drooping Mode **No. 670**

Select the load drooping mode - Only available in FVC+ mode.

No.	Name	Description
0	Static	Loading does not influence the amount of drooping.
1	Dynamic	Loading can momentarily influence the amount of drooping.

P2.10.2.2 Load Drooping **No. 671**

Set the load drooping amount in % of nominal motor speed at nominal load conditions.

P2.10.2.3 Load Drooping LP Tc **No. 672**

Set the load drooping low pass filter time constant.

P2.10.2.4 Load Drooping HP Tc No. 673

Set the load drooping high pass filter time constant. Only active in dynamic drooping mode.

P2.10.2.5 Drooping Removal Mode No. 4581

Select the drooping removal mode.

No.	Name	Description
0	Constant droop	Loading does not influence the amount of drooping.
1	Linear removal below transition speed	Load drooping gain is linearly reduced towards 0 % as a function of motor speed. Reduction applies for speeds below the transition speed setting (parameter No. 4582).
2	Linear below motor nominal speed	Load drooping gain is linearly reduced towards 0 % as a function of motor speed. Reduction applies for speeds below the motor nominal speed (parameter No. 402).

P2.10.2.6 Drooping Removal Transition Speed No. 4582

Set the drooping removal transition speed.

Load Drooping Assist

The load drooping assist function (LDA) helps in load balancing at low speeds between drives in applications where shafts of several motors are connected mechanically together. The function can be used from an external PLC either via fieldbus or analog I/O. An example of a load droop assisted winch system is depicted in the following figure.

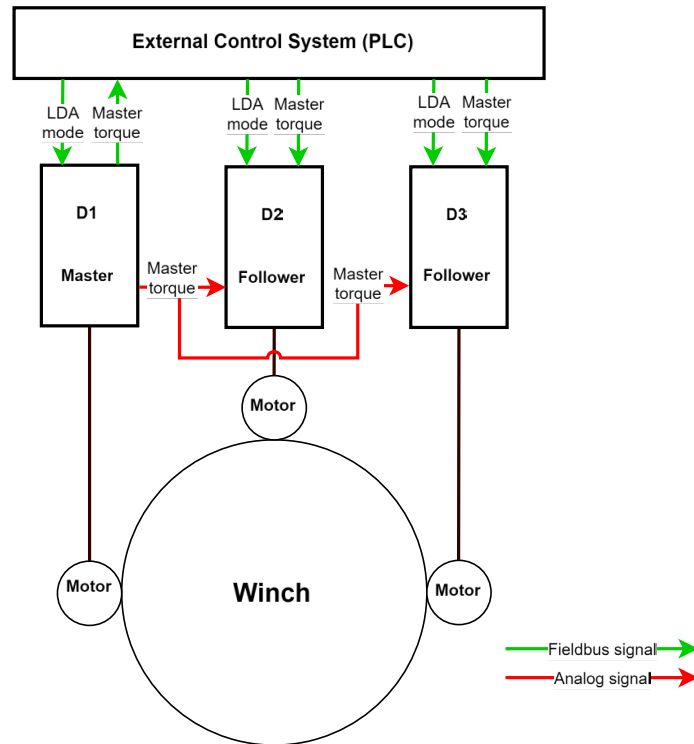

Figure 83: An example of a load drooping assisted multi-drive winch system.

The LDA function is activated once the motor speed is below the limit set with parameter **No. 4537**. Once the LDA is active, the follower(s) take the master drive's torque as an input and compare it to their own torque measurement. If the master's torque is higher than the torque of any of the followers, those followers increase their speed reference, thus increasing their own torque and assisting the master. Respectively, if the master's torque is smaller than the torque of any of the followers, the followers' speed reference decreases, thus helping in load balancing. A principal diagram of the LDA function is presented in the following figure.

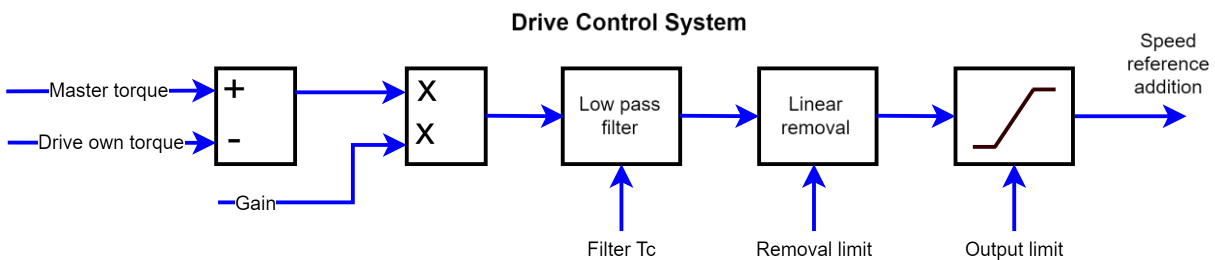

Figure 84: Load Drooping Assist control function diagram

If the master motor torque data is transferred via fieldbus, the master drive can be selected with the LDA mode parameter **No. 4570**, and the configuration can be changed during operation. If the data is sent via analog I/O, the master-follower roles are fixed based on I/O wirings, thus configuration cannot be changed during operation.

P2.10.2.7 Load Drooping Assist Mode **No. 4570**

Set the mode for the load drooping assist. With *Master Drive or Not Used* the function is not in use or this drive is the master torque source. With *Follower Drive: Master torque from FB* the drive gets master torque from fieldbus. With *Follower Drive: Master torque from I/O* the drive gets master torque from I/O.

No.	Name	Description
0	Master Drive or Not Used	Load drooping assist is either not used at all, or the drive acts as the LDA-master. The LDA function does not influence the drive's speed reference.
1	Follower Drive: Master torque from FB	The drive acts as a load drooping assist follower. The master torque data is obtained via fieldbus (parameter No. 4506). The LDA function effects the drive's speed reference when motor speed is below the removal limit set with parameter No. 4537 .
2	Follower Drive: Master torque from I/O	The drive acts as a load drooping assist follower. The master torque data is obtained via the analog input terminal defined with parameter No. 4583 . The LDA function effects the drive's speed reference when motor speed is below the removal limit set with parameter No. 4537 .

P2.10.2.8 Load Drooping Assist Gain **No. 4508**

Set the gain for the load drooping assist function.

P2.10.2.9 Load Drooping Assist Filter Tc **No. 4536**

Set the low-pass filter time constant for the load drooping assist function.

P2.10.2.10 Load Drooping Assist Removal Limit **No. 4537**

Set the removal limit for the load drooping assist function. The function assists in load drooping when the speed reference is below this setting.

P2.10.2.11 Load Drooping Assist Output Limit **No. 4579**

Set the output limit for the load drooping assist function.

P2.10.2.12 Master Motor Torque Failure Protection **No. 4580**

Enable live zero or fieldbus communication error protection (fieldbus fault, process data timeout or fieldbus watchdog) for master motor torque measurement. The load drooping assist is disabled if master motor torque is fed through analog input and the value of the selected terminal goes below its Live Zero Threshold. Or if master motor torque is fed through fieldbus, one of the fieldbus communication errors is detected, and the response for the fieldbus error is set to warning.

No.	Name	Description
0	Disabled	A failure in receiving the master drive's motor torque measurement will not effect the load drooping assist function.
1	Enabled	A failure in receiving the master drive's motor torque measurement will disable the load drooping assist function.

2.10.2.13 Load Drooping Assist Analog Input No. 4583

Select the analog input terminal for the master drive torque in the load drooping assist function.

No.	Name	Description
0	None	No input is selected and a value of 0% is applied to the associated function.
5	50 %	A virtual value of 50 % is applied to the associated function.
10	100 %	A virtual value of 100 % is applied to the associated function.
*	Available analog input terminals	A dynamically generated selection of available analog input terminals is presented as an option. The specific set depends on the type and number of I/O options installed in the system.

2.10.2.14 Load Drooping Assist AI Scale No. 4584

Set the scaling factor which converts the voltage/current of the master motor torque analog input channel to in % of motor nominal torque. For example, with setting 100% the value of 100% is achieved with +10 V input to a +10 V/0 V analog channel. Correspondingly -100% would be achieved with 0 V input.

2.10.2.15 Load Drooping Assist Force Off Input No. 4585

Select the digital input for forcing off the load drooping assist, for example during emergency situations. When input is applied the output of the load drooping assist will decay to 0 according to load drooping assist filter Tc.

No.	Name	Description
0	None (False)	No input is selected. A virtual value of FALSE is applied.
1	None (True)	No input is selected. A virtual value of TRUE is applied.
*	Fieldbus control word 1/2 digital input bits	Fieldbus CTW1 digital input bits 12-15 and CTW2 digital input bits 0-15 will be presented as options.
*	Logic Digital I/O virtual terminals	Virtual digital outputs from the Logic Feature function blocks are presented as input options.
*	Available digital input terminals	A dynamically generated selection of available digital input terminals is presented as an option. The specific set depends on the type and number of I/O options installed in the system.

7.3.11 Drive Control

This group holds settings related to the drive's modulation, power unit, fan control and rectifying.

7.3.11.1 Modulation

This group contains parameters for fine-tuning modulation settings. User can set e.g. the desired switching frequency and other modulator settings.

Minimum Pulse Number Function

The minimum pulse number function (operated with parameters **No. 5122** and **No. 5123**) is a performance enhancing function designed especially for high-speed drives ($f_{nom} > 100$ Hz). It enables the use of low switching frequency at low speeds, but at high speeds the switching frequency is increased in proportion to drive output frequency. This way, for example, the drive's thermal stress becomes reduced at lower speeds, while at higher speeds the drive THDi remains at acceptable level.

The operational principle of the function is presented in Figure 85. When the output frequency (f_{out}) is lower than the

$$f_{MinPulseLimit} = \frac{f_{sw}}{MinPulseNumber},$$

the switching frequency is taken from parameters **No. 2983** or **No. 2984**. With higher output frequency the switching frequency follows equation

$$f_{sw} = MinPulseNumber \times f_{out},$$

until f_{sw} is limited by **Max. Switching Frequency (No. 2924)**.

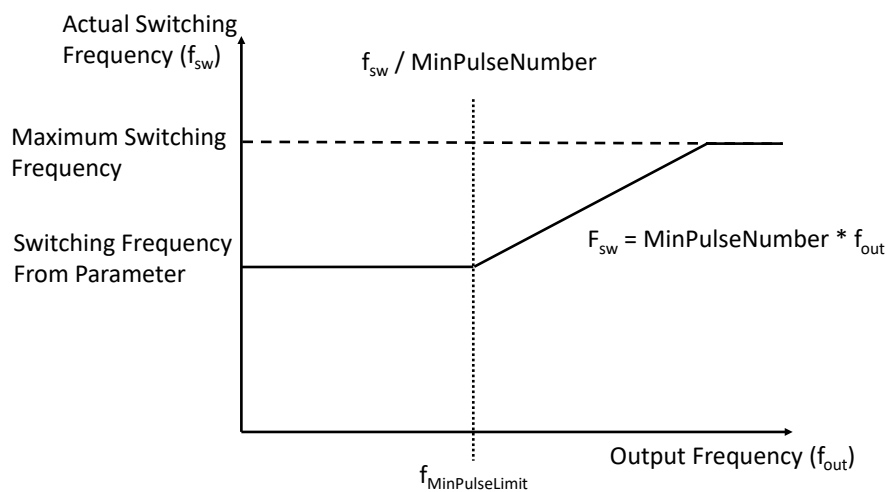

Figure 85: Operation principle of minimum pulse number function.

P2.11.1.1 Switching Frequency No. 2983

Set the switching frequency request. This parameter is used when output filter type is set to none with **No. 5501**. Note that the actual switching frequency is regulated by the drive itself, and it may be derated by some protections function.

P2.11.1.2 Switching Frequency Motor With Sine Filter No. 2984

Set the switching frequency request. This parameter is used when output filter type is set to sine-wave filter with **No. 5501**. Note that the actual switching frequency is regulated by the drive itself, and it may be derated by some protections function.

P2.11.1.3 Max. Switching Frequency No. 2924

Set the maximum switching frequency.

P2.11.1.4 Min. Switching Frequency No. 2925

Set the minimum switching frequency.

P2.11.1.5 Modulator Options **No. 5093**

Advanced modulator options.

Bit. No.	Name	Description
0	Disable compensation of non-linearities	
1	Disable deadtime compensation based on feedback	
2	Use filtered DC voltage over whole speed range	
3	Prohibit pulse dropping when reaching voltage ceiling	
4	Optimized minimum pulse logic for carrier synchronization	

P2.11.1.6 Overmodulation **No. 5094**

Enables the modulation index to exceed 1.0.

No.	Name	Description
0	Disabled	
1	Enabled	

P2.11.1.7 Modulator Type **No. 5100**

Select the modulator type.

No.	Name	Description
1	SVPWM	Standard Space Vector Pulse Width Modulation. Use in special applications, where automatic change of PWM carrier frequency and modulation pattern might cause issues (motor interfaced via filters or a transformer and so on). Drive derating is required.
6	Optimized	The modulator optimizes the trade-off between losses and harmonics. Recommended selection for most applications. Modulation parameters are automatically set.

P2.11.1.8 Minimum Pulse Number Mode **No. 5122**

Set the minimum pulse number mode.

No.	Name	Description
0	Disabled	Disables the minimum pulse number function. Switching frequency is determined as per parameters No. 2983 and No. 2984 .
2	User Selection	The Minimum Pulse Number set with parameter No. 5123 is used.

P2.11.1.9 Minimum Pulse Number **No. 5123**

Set the minimum number of switching cycles per motor electrical period. This is used when parameter **No. 5122** Minimum Pulse Number Mode is set to User Selection.

P2.11.1.10 Output Phase Sequence **No. 431**

Set the output phase sequence. This function virtually swaps the output phases, which can be used to change the direction of motor rotation without having to physically rewire motor cables.

No.	Name	Description
0	UVW	-
1	WVU	-

NOTICE

This setting applies only for frequency converter drives.

7.3.11.2 Power Unit Settings

This group contains parameters for setting up the drive's power unit(s).

P2.11.2.1 Power Unit Enable Mask **No. 2835**

Select which of the commissioned power units are enabled.

The value is given bitwise per each unit. Bit 0 corresponds to the first port in the Star coupler board, and bit 15 to the 16th port and so on. An active bit enables the corresponding power unit, and an inactive bit disables it.

This parameter is relevant only for drives with multiple power units, connected to the control board with the Star coupler board. Faulty or redundant power units can be disabled temporarily to allow running with reduced capacity. All internal protection functions adjust to the amount of enabled power units.

WARNING

Depending on the system's hardware configuration, it might be necessary to galvanically isolate the disabled units and all associated filters from the system. Failing to do so may increase the risk of resonance and damage the rest of the system. Please, contact Danfoss technical support for further instructions before using this functionality.

NOTICE

This parameter cannot be edited when the drive is running.

NOTICE

After Factory Reset or Node Commissioning the drive will automatically set this parameter to activate the nominal number of power units starting sequentially from the first port of the Star coupler board. If the drive has several power units, but this parameter does not have the correct value at initial start, it is recommended to run Factory Reset and power-cycle the drive. This operation will reset the Power Unit Enable Mask to correspond with the nominal amount of power units.

P2.11.2.2 Unit Voltage Class **No. 2832**

Select the unit voltage class to optimize the performance of the drive. Each power unit is rated for a wide voltage range which the drive can operate in. This parameter is used to specify a narrower band within that range to determine optimized values for the unit's nominal voltage and current. The DC-link nominal voltage is calculated automatically whenever this parameter is changed.

No.	Name	Description
1	Low-voltage range	Unit nominal voltage and current are set according to the lowest end of the unit's voltage range. <ul style="list-style-type: none"> • For example, for T5-units this range is 380-440 V AC. • For example, for T7-units this range is 525-550 V AC.
2	Mid-voltage range	Unit nominal voltage and current are set according to the middle of the unit's voltage range. <ul style="list-style-type: none"> • For example, for T5-units this range is 440-480 V AC. • For example, for T7-units this range is 550-600 V AC.
3	High-voltage range	Unit nominal voltage and current are set according to the highest end of the unit's voltage range. <ul style="list-style-type: none"> • For example, for T5-units this range is 480-500 V AC. • For example, for T7-units this range is 600-690 V AC.
4	Wide-voltage range	Unit nominal voltage and current are set according to the unit's whole voltage range. <ul style="list-style-type: none"> • For example, for T5-units this range is 380-500 V AC. • For example, for T7-units this range is 525-690 V AC.

P2.11.2.3 Overload Mode **No. 2833**

Select the overload mode. Overloading mode selects an overtemperature protection profile for the drive, effecting current limits and protection activation times. With a higher overloading mode, the drive will operate in a greater degree of overloading before protections take effect. Specific limits and activation delays depend on the conditions.

No.	Name	Description
0	Automatic	The drive automatically determines whether to use the Low or High Overload Mode.
1	Low overload (LO)	The drive uses the lower overloading profile. Overtemperature protection is activated with a lesser degree of overload.
2	High overload (HO1)	The drive uses a higher overloading profile. Overtemperature protection is activated with a higher degree of overload.
3	High overload increased duty (HO2)	The drive uses the highest overloading profile. Overtemperature protection is activated with the highest degree of overload.

P2.11.2.4 DC-link Voltage Measurement Corr. Gain **No. 6535**

Set the DC-link voltage measurement correction gain for parallel units.

P2.11.2.5 DC-link Voltage Measurement Corr. Offset **No. 6534**

Set the DC-link voltage measurement correction offset for parallel units.

P2.11.2.6 HF DC-link Filter Mode **No. 2944**

Select the mode of the high-frequency filter in the DC link.

No.	Name	Description
0	Filter inactive	
1	Filter active	

No.	Name	Description
2	Fiter matches grid type selection	

7.3.11.3 Cooling Fan Control

This group contains parameters for setting up the control of the drive's cooling fans. Note that these parameters are relevant only for air cooled units.

P2.11.3.1 Main Fan Minimum Speed No. 2932

Set the minimum speed of the main cooling fan. The main cooling fan(s) handles the cooling demand for the power modules and passive components placed in the cooling channel. Note that the fan's actual speed depends on the operating conditions of the drive.

7.3.11.4 Rectifier Settings

Note that the following parameters are only available for units with a rectifier.

P2.11.4.1 Grid Type No. 2942

Select the grid type of the supply system. If set to *As grid type*, the selection affects the setting of **RFI Filter Mode (No. 2943)** and **HF DC-link Filter Mode (No. 2944)**.

No.	Name	Description
0	TN	
1	TT	
2	IT	
3	HRG	
4	Grounded Delta	

P2.11.4.2 RFI Filter Mode No. 2943

Select the Radio Frequency Interference (RFI) filter mode.

No.	Name	Description
0	Filter inactive	
1	Filter active	
2	Fiter matches grid type selection	

P2.11.4.3 Supply Mode No. 1328

Select the supply mode.

This parameter is used, if the drive hardware is designed for both AC and DC supplies. Supply capabilities vary depending on the type and the size of the drive.

For example, low-power frequency converter hardware typically allows the drive to be supplied either by AC (through the inbuilt rectifier) or by DC (through the DC connectors). High-power system modules, on the other hand, are typically designed for common dc-bus applications, meaning that the drive hardware has DC-connectors only (no inbuilt rectifier or AC supply).

No.	Name	Description
0	AC	Drive is supplied through the AC terminals (if available)
1	DC	Drive is supplied through the DC terminals (if available)

7.3.12 Protections and Responses

This group contains parameters for applying most the drive's protection related configurations.

7.3.12.1 General Settings

P2.12.1.1 Retry after Fault No. 2927

Enables retry functionality (ride-through) functionality for the following fault type events. The number of retry attempts and the retry window depend on the event and the size and rating of the power unit.

No.	Name	Description
0	Disabled	
1	Enabled	

The following fault type events are retry-capable:

Name	Number	Name	Number	Name	Number
Ground Fault 2	4354	Output Current High 1	4369	Output Current High 2	4370
Brake Ch. Switch Shorted	4403	DC-link Voltage Low	4146	DC-link Voltage High 2	4144

P2.12.1.2 Smart Derate Mode No. 2345

Select the level of derating if the drive's nominal operational limits have been exceeded. The drive features multiple protection functions that can derate the switching frequency of the drive, to avoid operating conditions that are harmful for the drive. This parameter can be used to influence the degree of derating.

No.	Name	Description
0	Maximum derating	When switching frequency derating is applied the drive will reduce switching frequency the maximum possible amount. The actual amount of reduction depends on the case.
1	Minimum derating	When switching frequency derating is applied the drive will reduce switching frequency the minimum possible amount. The actual amount of reduction depends on the case.

7.3.12.2 Responses

This group contains response selections for miscellaneous protections. Excessive voltage ripples are detected when the peak-to-peak amplitude of the DC-voltage exceeds the drive's internal limit for an excess amount of time. Both the limit and time depend on the power unit type and rating.

NOTICE

All response selection parameters (not limited to this group) will require for the respective event not to be active for the parameter to be editable.

P2.12.2.1 DC-link Voltage Ripple Response No. 2929

Select the mode of excessive DC-link voltage ripple protection. Excessive voltage ripples are detected when the peak-to-peak amplitude of the DC voltage exceeds the drive's internal limit for too long a time. Both the limit and time depend on the power unit type and rating.

No.	Name	Description
0	Disabled	Effectively nothing is done when excessive rippling is detected.
1	Fault, coast	After detecting excessive ripples for too long, the drive will issue a fault and stop modulation.
2	Automatically derate + Fault, coast	After detecting excessive ripples, the drive will derate the maximum allowed output frequency. If the derating does not reduce the rippling soon enough, the drive will issue a fault and stop modulation. The derating is released if the ripple amplitude is reduced below the detection limit.

P2.12.2.2 Inverter Thermal Overload Response No. 2341

Select the mode of inverter thermal overload protection.

No.	Name	Description
1	Fault, coast	The drive will issue a fault and stop modulation.
2	Automatically derate	The drive will derate the maximum allowed output current to mitigate the issue. The derating will be undone when the drive exits the overload operation window.
3	Warning	The drive will issue a warning.

P2.12.2.3 ETR Overtemperature Response No. 2825

Select the response to motor overtemperature indicated by the electronic thermal relay (ETR). This function is an internal calculation of the motor temperature. It is not recommended to use this if the motor is externally cooled.

No.	Name	Description
0	No response	-
1	Info	The drive will issue an info event.
3	Warning	The drive will issue a warning event.
9	Fault, ramp to coast	The drive will issue a fault event and ramp motor speed to zero before stopping modulation.
10	Fault, coast	The drive will issue a fault event and stop modulation immediately.

P2.12.2.4 Motor Sync Loss No. 2922

Select the drive response if the synchronization between motor and drive is lost. This is only relevant when using a permanent magnet or synchronous reluctance motor.

No.	Name	Description
0	Disabled	-
1	Fault, coast	The drive will issue a fault event and stop modulation immediately.
2	Warning	The drive will issue a warning event.

P2.12.2.5 Missing Phase Start-up Detection No. 6070

Enables detection of missing motor phase at start-up.

No.	Name	Description
0	Disabled	-
1	Enabled	Enables the activation of the Missing Motor Phase event. The detection is done by monitoring the phase voltages.

P2.12.2.6 Missing Motor Phase Response No. 2348

Select the response to a missing motor phase event.

No.	Name	Description
0	Disabled	-
2	Warning	The drive will issue a warning event.
1	Fault, coast	The drive will issue a fault event and stop modulation immediately.

P2.12.2.7 Disconnected Motor Response No. 2349

Select the response to a disconnected motor. A disconnected motor is detected if all three phases are missing.

No.	Name	Description
0	No response	-
2	Warning	The drive will issue a warning event.
1	Fault, coast	The drive will issue a fault event and stop modulation immediately.
3	Motor Check	The drive is waiting for the motor to be connected.

P2.12.2.8 Motor Feedback Failure Response No. 4600

Select the drive response to Encoder/Resolver option related failures (Event No. 4607 Internal Communication Fault, No. 4602 Option Communication Fault, and No. 4417 Feedback Option Fault).

No.	Name	Description
3	Switch to Open Loop and Continue	A warning is issued, and the feedback mode is temporarily changed to Open Loop and the drive will continue running.
9	Switch to Open Loop and Ramp to Stop	The drive will change the feedback mode temporarily to Open Loop, issue a fault and ramp the motor speed to zero before stopping modulation.
10	Fault, coast	The drive will issue a fault event and stop modulation immediately.

P2.12.2.9 Bad Speed Feedback Response No. 4628

Select the drive response to unreliable speed feedback value.

No.	Name	Description
0	No response	-
1	Info	The drive will issue an info event.
3	Warning	The drive will issue a warning event.
9	Fault, ramp to coast	The drive will issue a fault event and ramp motor speed to zero before stopping modulation.
10	Fault, coast	The drive will issue a fault event and stop modulation immediately.

P2.12.2.10 Invalid Grid Frequency Response No. 2337

Select the response after detection of invalid grid frequency. Note that this parameter applies only to units with a rectifier.

No.	Name	Description
1	Fault, coast	The drive will issue a fault event and stop modulation immediately.
2	Automatically derate	The DC-link current is limited, limiting motor power indirectly.
3	Warning	The drive will issue a warning event.

P2.12.2.11 Missing Grid Phase Response **No. 2338**

Select the response after detection of a missing grid phase. Note that this parameter applies only to units with a rectifier.

No.	Name	Description
1	Fault, coast	The drive will issue a fault event and stop modulation immediately.
2	Automatically derate	The DC-link current is limited, limiting motor power indirectly.
3	Warning	The drive will issue a warning event.

P2.12.2.12 Grid Undervoltage Protection **No. 2344**

Enables the grid undervoltage protection. The event activates when the grid voltage is 20% below the selected voltage class level. The voltage class is defined with parameter **No. 2832**.

No.	Name	Description
0	Disabled	-
1	Enabled	-

P2.12.2.13 Grid Voltage Imbalance Response **No. 9056**

Select the mode of grid imbalance protection. This response activates if 3.3% or greater imbalance is seen between the phase voltages.

No.	Name	Description
0	Off	-
1	Fault or Warning	A warning is issued and escalated into a fault if the situation persists or appears multiple times in a short window. The specific time of the window depends on the unit specifications.
2	Automatically derate	The DC-link current is limited, limiting motor power indirectly.

P2.12.2.14 Rectifier Thermal Overload Response **No. 2340**

Select the mode of rectifier thermal overload protection. Rectifier thermal overload is detected if the drive operates for an extended period at a given rectifier current level. Specific current levels and trip times depend on the power unit type and rating.

No.	Name	Description
1	Fault, coast	The drive will issue a fault and stop modulation.
2	Automatically derate	The drive will derate the rectifier current (DC-link current) to mitigate the issue. The derating will be undone when the drive exits the overload operation window.
3	Warning	The drive will issue a warning.

7.3.12.3 External Event

External events are protection functions which can be configured to trigger drive events (warnings, faults, and so on) through inputs. Two separate events are available, both can be triggered with an active-high or active-low signals.

P2.12.3.1 External Event 1 Input**No. 4557**

Select an input for the external event.

No.	Name	Description
0	None (False)	No input is selected. A virtual value of FALSE is applied.
1	None (True)	No input is selected. A virtual value of TRUE is applied.
*	Fieldbus control word 1/2 digital input bits	Fieldbus CTW1 digital input bits 12-15 and CTW2 digital input bits 0-15 will be presented as options.
*	Logic Digital I/O virtual terminals	Virtual digital outputs from the Logic Feature function blocks are presented as input options.
*	Available digital input terminals	A dynamically generated selection of available digital input terminals is presented as an option. The specific set depends on the type and number of I/O options installed in the system.

P2.12.3.2 Ext. Event 1 Inverse Input**No. 4558**

Select an inverted input for the external event 1 function.

No.	Name	Description
0	None (False)	No input is selected. A virtual value of FALSE is applied.
1	None (True)	No input is selected. A virtual value of TRUE is applied.
*	Fieldbus control word 1/2 digital input bits	Fieldbus CTW1 digital input bits 12-15 and CTW2 digital input bits 0-15 will be presented as options.
*	Logic Digital I/O virtual terminals	Virtual digital outputs from the Logic Feature function blocks are presented as input options.
*	Available digital input terminals	A dynamically generated selection of available digital input terminals is presented as an option. The specific set depends on the type and number of I/O options installed in the system.

P2.12.3.3 External Event 1 Response**No. 4559**

Select the response to an external event.

No.	Name	Description
0	No response	-
1	Info	The drive will issue an info event.
3	Warning	The drive will issue a warning event.
9	Fault, ramp to coast	The drive will issue a fault event and ramp motor speed to zero before stopping modulation.
10	Fault, coast	The drive will issue a fault event and stop modulation immediately.

P2.12.3.4 External Event 2 Input**No. 4560**

Select an input for the external event.

No.	Name	Description
0	None (False)	No input is selected. A virtual value of FALSE is applied.
1	None (True)	No input is selected. A virtual value of TRUE is applied.
*	Fieldbus control word 1/2 digital input bits	Fieldbus CTW1 digital input bits 12-15 and CTW2 digital input bits 0-15 will be presented as options.
*	Logic Digital I/O virtual terminals	Virtual digital outputs from the Logic Feature function blocks are presented as input options.
*	Available digital input terminals	A dynamically generated selection of available digital input terminals is presented as an option. The specific set depends on the type and number of I/O options installed in the system.

P2.12.3.5 Ext. Event 2 Inverse Input**No. 4561**

Select an inverted input for the external event 2 function.

No.	Name	Description
0	None (False)	No input is selected. A virtual value of FALSE is applied.
1	None (True)	No input is selected. A virtual value of TRUE is applied.
*	Fieldbus control word 1/2 digital input bits	Fieldbus CTW1 digital input bits 12-15 and CTW2 digital input bits 0-15 will be presented as options.
*	Logic Digital I/O virtual terminals	Virtual digital outputs from the Logic Feature function blocks are presented as input options.
*	Available digital input terminals	A dynamically generated selection of available digital input terminals is presented as an option. The specific set depends on the type and number of I/O options installed in the system.

P2.12.3.6 External Event 2 Response**No. 4562**

Select the response to an external event.

No.	Name	Description
0	No response	-
1	Info	The drive will issue an info event.
3	Warning	The drive will issue a warning event.
9	Fault, ramp to coast	The drive will issue a fault event and ramp motor speed to zero before stopping modulation.
10	Fault, coast	The drive will issue a fault event and stop modulation immediately.

P2.12.3.7 External Event Active Output**No. 5184**

Select an output indicating an external event.

No.	Name	Description
0	None	No output is selected.
*	Fieldbus status word 2 digital output bits	Fieldbus CTW2 digital output bits 0-15 will be presented as options.
*	Logic Digital I/O virtual terminals	Virtual digital inputs to the Logic Feature function blocks will be presented as output options.
*	Available digital output and relay terminals	A dynamically generated selection of available digital output and relay terminals is presented as an option. The specific set depends on the type and number of I/O options installed in the system.

7.3.12.4 Cooling Monitor

The cooling monitor feature is relative for liquid cooled drives. It is designed to allow the drive to receive a single digital signal from the cooling unit when it experiences errors. The drive will then act as configured.

P2.12.4.1 Cooling Monitor Input**No. 2400**

Select the input for the negated cooling monitor signal.

No.	Name	Description
0	None (False)	No input is selected. A virtual value of FALSE is applied.
1	None (True)	No input is selected. A virtual value of TRUE is applied.
*	Fieldbus control word 1/2 digital input bits	Fieldbus CTW1 digital input bits 12-15 and CTW2 digital input bits 0-15 will be presented as options.
*	Logic Digital I/O virtual terminals	Virtual digital outputs from the Logic Feature function blocks are presented as input options.
*	Available digital input terminals	A dynamically generated selection of available digital input terminals is presented as an option. The specific set depends on the type and number of I/O options installed in the system.

P2.12.4.2 Cooling Monitor Fault Delay**No. 2401**

Set a delay before the cooling monitor issues a fault. Only valid if fault is selected.

P2.12.4.3 Cooling Monitor Response

No. 2402

Select the response to a missing cooling monitor signal. The response is selected for both stopped and running states.

No.	Name	Description
0	Warning while running	The drive issues a warning if the cooling signal is lost, and the drive is running.
1	Warning	The drive issues a warning if the cooling signal is lost.
2	Warning, Fault (coast) after Timeout while running	The drive issues a warning if the cooling signal is lost. If the drive is running the event is escalated into a fault after the fault delay (No. 2401).
3	Warning and Fault (coast) after Timeout while running	The drive issues a warning if the cooling signal is lost, and the drive is running. After the fault delay (No. 2401) the event is escalated into a fault.

7.3.12.5 Measured Temp. Protection

The measured temperature protection offers 10 individual protection channels for monitoring temperatures of external devices like filters or motor windings through temperature probes. Each protection can be configured to trigger an individual event, which can be used to identify the source of the high temperature measurement.

Each protection has two configurable stages, as illustrated in the following figure. Stage 1 is used to trigger a warning, while stage 2 can be used to trigger a more severe event, which may possibly stop the drive (fault). The activation levels of both stages and the event response of stage 2 can be configured. The levels of both stages can be configured to be the same, if two stages are unnecessary.

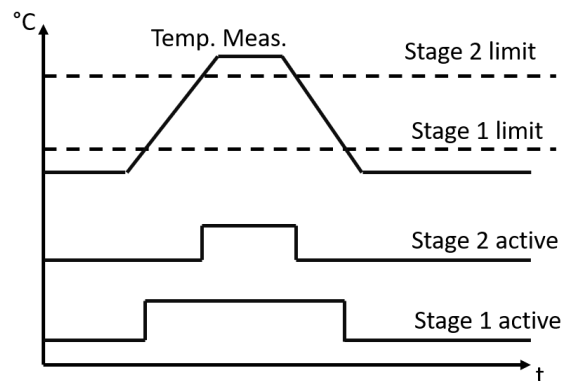

Figure 86: Operation principle of temperature measurement protection function.

Additionally, a temperature measurement range check feature is also available, as presented in the following figure. A range can be defined for checking the validity of each measured temperature protection. If the absolute measurement value of any protection exceeds this range, a separate event can be triggered.

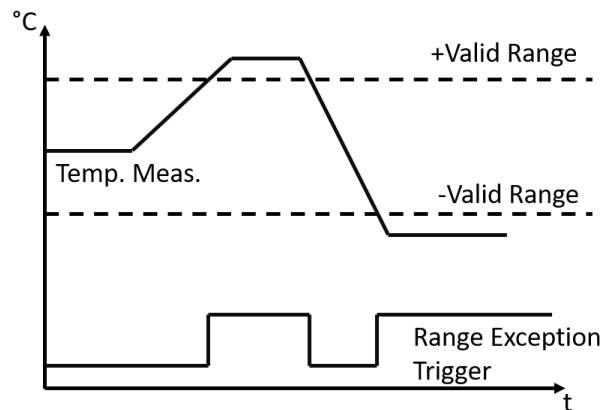

Figure 87: Operation principle of temperature measurement range check.

NOTICE

The range check is also sensor-specific, even though its limits and response are common for all sensors. If the range-check exception is triggered for a particular sensor, Stage 2 protection is deactivated for that sensor. This prevents, for example, a wire break (which would cause a rapid temperature rise above the Stage 2 limit in the faulty sensor) from generating a Stage 2 event. Instead, the drive executes the common measurement range check response and generates a sensor-specific Stage 1 warning.

If the common range check is disabled (the response is set to *No Response*), Stage 2 protection will be activated according to the response defined by the sensor-specific *Temp. Limit 2 Response* parameters.

7.3.12.5.1 Temp. 1 Protection

P2.12.5.1.1 Temp. 1 Input No. 5206

Select the temperature sensor input for the temperature protection.

No.	Name	Description
0	None	No input is selected.
*	Available temperature measurement terminals	A dynamically generated selection of available temperature measurement terminals is presented as an option. The specific set depends on the type and number of temperature options installed in the system.

P2.12.5.1.2 Temp. 1 Limit 1 No. 5207

Set the temperature level for issuing a warning.

P2.12.5.1.3 Temp. 1 Limit 2 No. 5208

Set the temperature level for issuing a protection response.

P2.12.5.1.4 Temp. 1 Limit 2 Response**No. 5209**

Select the response for exceeding the limit.

No.	Name	Description
0	No response	-
1	Info	The drive will issue an info event.
3	Warning	The drive will issue a warning event.
9	Fault, ramp to coast	The drive will issue a fault event and ramp motor speed to zero before stopping modulation.
10	Fault, coast	The drive will issue a fault event and stop modulation immediately.

7.3.12.5.2 Temp. 2 Protection**P2.12.5.2.1 Temp. 2 Input No. 5210**

Select the temperature sensor input for the temperature protection.

No.	Name	Description
0	None	No input is selected.
*	Available temperature measurement terminals	A dynamically generated selection of available temperature measurement terminals is presented as an option. The specific set depends on the type and number of temperature options installed in the system.

P2.12.5.2.2 Temp. 2 Limit 1 No. 5211

Set the temperature level for issuing a warning.

P2.12.5.2.3 Temp. 2 Limit 2 No. 5212

Set the temperature level for issuing a protection response.

P2.12.5.2.4 Temp. 2 Limit 2 Response No. 5213

Select the response for exceeding the limit.

No.	Name	Description
0	No response	-
1	Info	The drive will issue an info event.
3	Warning	The drive will issue a warning event.
9	Fault, ramp to coast	The drive will issue a fault event and ramp motor speed to zero before stopping modulation.
10	Fault, coast	The drive will issue a fault event and stop modulation immediately.

7.3.12.5.3 Temp. 3 Protection**P2.12.5.3.1 Temp. 3 Input No. 5214**

Select the temperature sensor input for the temperature protection.

No.	Name	Description
0	None	No input is selected.
*	Available temperature measurement terminals	A dynamically generated selection of available temperature measurement terminals is presented as an option. The specific set depends on the type and number of temperature options installed in the system.

P2.12.5.3.2 Temp. 3 Limit 1 No. 5215

Set the temperature level for issuing a warning.

P2.12.5.3.3 Temp. 3 Limit 2 No. 5216

Set the temperature level for issuing a protection response.

P2.12.5.3.4 Temp. 3 Limit 2 Response No. 5217

Select the response for exceeding the limit.

No.	Name	Description
0	No response	-
1	Info	The drive will issue an info event.
3	Warning	The drive will issue a warning event.
9	Fault, ramp to coast	The drive will issue a fault event and ramp motor speed to zero before stopping modulation.
10	Fault, coast	The drive will issue a fault event and stop modulation immediately.

7.3.12.5.4 Temp. 4 Protection

P2.12.5.4.1 Temp. 4 Input No. 5218

Select the temperature sensor input for the temperature protection.

No.	Name	Description
0	None	No input is selected.
*	Available temperature measurement terminals	A dynamically generated selection of available temperature measurement terminals is presented as an option. The specific set depends on the type and number of temperature options installed in the system.

P2.12.5.4.2 Temp. 4 Limit 1 No. 5219

Set the temperature level for issuing a warning.

P2.12.5.4.3 Temp. 4 Limit 2 No. 5220

Set the temperature level for issuing a protection response.

P2.12.5.4.4 Temp. 4 Limit 2 Response No. 5221

Select the response for exceeding the limit.

No.	Name	Description
0	No response	-

No.	Name	Description
1	Info	The drive will issue an info event.
3	Warning	The drive will issue a warning event.
9	Fault, ramp to coast	The drive will issue a fault event and ramp motor speed to zero before stopping modulation.
10	Fault, coast	The drive will issue a fault event and stop modulation immediately.

7.3.12.5.5 Temp. 5 Protection

P2.12.5.5.1 Temp. 5 Input No. 5222

Select the temperature sensor input for the temperature protection.

No.	Name	Description
0	None	No input is selected.
*	Available temperature measurement terminals	A dynamically generated selection of available temperature measurement terminals is presented as an option. The specific set depends on the type and number of temperature options installed in the system.

P2.12.5.5.2 Temp. 5 Limit 1 No. 5223

Set the temperature level for issuing a warning.

P2.12.5.5.3 Temp. 5 Limit 2 No. 5224

Set the temperature level for issuing a protection response.

P2.12.5.5.4 Temp. 5 Limit 2 Response No. 5225

Select the response for exceeding the limit.

No.	Name	Description
0	No response	-
1	Info	The drive will issue an info event.
3	Warning	The drive will issue a warning event.
9	Fault, ramp to coast	The drive will issue a fault event and ramp motor speed to zero before stopping modulation.
10	Fault, coast	The drive will issue a fault event and stop modulation immediately.

7.3.12.5.6 Temp. 6 Protection

P2.12.5.6.1 Temp. 6 Input No. 5226

Select the temperature sensor input for the temperature protection.

No.	Name	Description
0	None	No input is selected.
*	Available temperature measurement terminals	A dynamically generated selection of available temperature measurement terminals is presented as an option. The specific set depends on the type and number of temperature options installed in the system.

P2.12.5.6.2 Temp. 6 Limit 1 No. 5227

Set the temperature level for issuing a warning.

P2.12.5.6.3 Temp. 6 Limit 2 No. 5228

Set the temperature level for issuing a protection response.

P2.12.5.6.4 Temp. 6 Limit 2 Response No. 5229

Select the response for exceeding the limit.

No.	Name	Description
0	No response	-
1	Info	The drive will issue an info event.
3	Warning	The drive will issue a warning event.
9	Fault, ramp to coast	The drive will issue a fault event and ramp motor speed to zero before stopping modulation.
10	Fault, coast	The drive will issue a fault event and stop modulation immediately.

7.3.12.5.7 Temp. 7 Protection**P2.12.5.7.1 Temp. 7 Input No. 5239**

Select the temperature sensor input for the temperature protection.

No.	Name	Description
0	None	No input is selected.
*	Available temperature measurement terminals	A dynamically generated selection of available temperature measurement terminals is presented as an option. The specific set depends on the type and number of temperature options installed in the system.

P2.12.5.7.2 Temp. 7 Limit 1 No. 5243

Set the temperature level for issuing a warning.

P2.12.5.7.3 Temp. 7 Limit 2 No. 5269

Set the temperature level for issuing a protection response.

P2.12.5.7.4 Temp. 7 Limit 2 Response**No. 5235**

Select the response for exceeding the limit.

No.	Name	Description
0	No response	-
1	Info	The drive will issue an info event.
3	Warning	The drive will issue a warning event.
9	Fault, ramp to coast	The drive will issue a fault event and ramp motor speed to zero before stopping modulation.
10	Fault, coast	The drive will issue a fault event and stop modulation immediately.

7.3.12.5.8 Temp. Protection 8**P2.12.5.8.1 Temp. 8 Input No. 5240**

Select the temperature sensor input for the temperature protection.

No.	Name	Description
0	None	No input is selected.
*	Available temperature measurement terminals	A dynamically generated selection of available temperature measurement terminals is presented as an option. The specific set depends on the type and number of temperature options installed in the system.

P2.12.5.8.2 Temp. 8 Limit 1 No. 5247

Set the temperature level for issuing a warning.

P2.12.5.8.3 Temp. 8 Limit 2 No. 5270

Set the temperature level for issuing a protection response.

P2.12.5.8.4 Temp. 8 Limit 2 Response**No. 5236**

Select the response for exceeding the limit.

No.	Name	Description
0	No response	-
1	Info	The drive will issue an info event.
3	Warning	The drive will issue a warning event.
9	Fault, ramp to coast	The drive will issue a fault event and ramp motor speed to zero before stopping modulation.
10	Fault, coast	The drive will issue a fault event and stop modulation immediately.

7.3.12.5.9 Temp. Protection 9**P2.12.5.9.1 Temp. 9 Input No. 5241**

Select the temperature sensor input for the temperature protection.

No.	Name	Description
0	None	No input is selected.
*	Available temperature measurement terminals	A dynamically generated selection of available temperature measurement terminals is presented as an option. The specific set depends on the type and number of temperature options installed in the system.

P2.12.5.9.2 Temp. 9 Limit 1 No. 5249

Set the temperature level for issuing a warning.

P2.12.5.9.3 Temp. 9 Limit 2 No. 5271

Set the temperature level for issuing a protection response.

P2.12.5.9.4 Temp. 9 Limit 2 Response No. 5237

Select the response for exceeding the limit.

No.	Name	Description
0	No response	-
1	Info	The drive will issue an info event.
3	Warning	The drive will issue a warning event.
9	Fault, ramp to coast	The drive will issue a fault event and ramp motor speed to zero before stopping modulation.
10	Fault, coast	The drive will issue a fault event and stop modulation immediately.

7.3.12.5.10 Temp. Protection 10

P2.12.5.10.1 Temp. 10 Input No. 5242

Select the temperature sensor input for the temperature protection.

No.	Name	Description
0	None	No input is selected.
*	Available temperature measurement terminals	A dynamically generated selection of available temperature measurement terminals is presented as an option. The specific set depends on the type and number of temperature options installed in the system.

P2.12.5.10.2 Temp. 10 Limit 1 No. 5268

Set the temperature level for issuing a warning.

P2.12.5.10.3 Temp. 10 Limit 2 No. 5272

Set the temperature level for issuing a protection response.

P2.12.5.10.4 Temp. 10 Limit 2 Response No. 5238

Select the response for exceeding the limit.

No.	Name	Description
0	No response	-

No.	Name	Description
1	Info	The drive will issue an info event.
3	Warning	The drive will issue a warning event.
9	Fault, ramp to coast	The drive will issue a fault event and ramp motor speed to zero before stopping modulation.
10	Fault, coast	The drive will issue a fault event and stop modulation immediately.

7.3.12.5.11 Common

P2.12.5.11.1 Meas. Valid Range No. 5230

Set a valid reading range for the temperature probe measurements. The first element of the array is the higher and the second element the lower limit. An event is triggered if 1 of the readings goes above the higher, or below the lower limit.

P2.12.5.11.2 Meas. Out of Range Response No. 5231

Select the drive response when 1 or more of the probes exceed the valid range.

No.	Name	Description
0	No response	-
1	Info	The drive will issue an info event.
3	Warning	The drive will issue a warning event.
9	Fault, ramp to coast	The drive will issue a fault event and ramp motor speed to zero before stopping modulation.
10	Fault, coast	The drive will issue a fault event and stop modulation immediately.

7.3.12.6 Motor Speed Error

The speed error protection compares the actual motor speed to the given speed reference. If the difference is greater than what is allowed, an event is triggered. If motor speed feedback is available and if observed speed control mode is used, the actual motor speed is defined through the feedback reading. Otherwise, the actual speed is derived from the drive's output variables. This feature can be used for detecting synchronization or feedback device reading errors, for instance.

P2.12.6.1 Speed Error Response No. 5080

Select the drive response to Speed Error event.

No.	Name	Description
0	No response	-
1	Info	The drive will issue an info event.
3	Warning	The drive will issue a warning event.
9	Fault, ramp to coast	The drive will issue a fault event and ramp motor speed to zero before stopping modulation.
10	Fault, coast	The drive will issue a fault event and stop modulation immediately.

P2.12.6.2 Speed Error Limit No. 5081

Set a limit for the acceptable error between the measured and requested speed in % of nominal speed.

P2.12.6.3 Speed Error Delay No. 5082

Set a delay after which the Speed Error event is detected.

7.3.12.7 Lost Load Detection

The purpose of the lost load detection is to ensure that there is load on the motor when the drive is running. If the motor loses its load there might be a problem in the process, for example, a broken belt or a dry pump. The protection acts in case the load torque falls below the set lost load detection torque level for the duration of the lost load detection delay. This protection is active if the motor speed is over 15 Hz.

P2.12.7.1 Lost-load Response No. 9072

Select an action for the lost-load detection. The lost-load detection is active if the motor speed is above 15 Hz.

No.	Name	Description
0	No response	-
1	Info	The drive will issue an info event.
3	Warning	The drive will issue a warning event.
9	Fault, ramp to coast	The drive will issue a fault event and ramp motor speed to zero before stopping modulation.
10	Fault, coast	The drive will issue a fault event and stop modulation immediately.

P2.12.7.2 Lost-load Detection Torque Level No. 9070

Set the minimum allowed torque level in % of nominal motor torque. The lost-load detection can be activated below the set level.

P2.12.7.3 Lost-load Detection Delay No. 9071

Set the minimum duration that the torque must be below the detection limit before activating the lost-load event.

7.3.12.8 Motor Stall Protection

The motor stall protection protects the motor from short time overload situations, caused for example by a stalled shaft. The following figure presents the stall protection operating principle. The inputs are Stall Current Limit, Stall Speed Limit and Stall Time. The stall protection acts if the motor current is higher than the stall current limit and the motor speed is lower than the stall speed limit (that is, stall condition is detected) for the duration of the stall time.

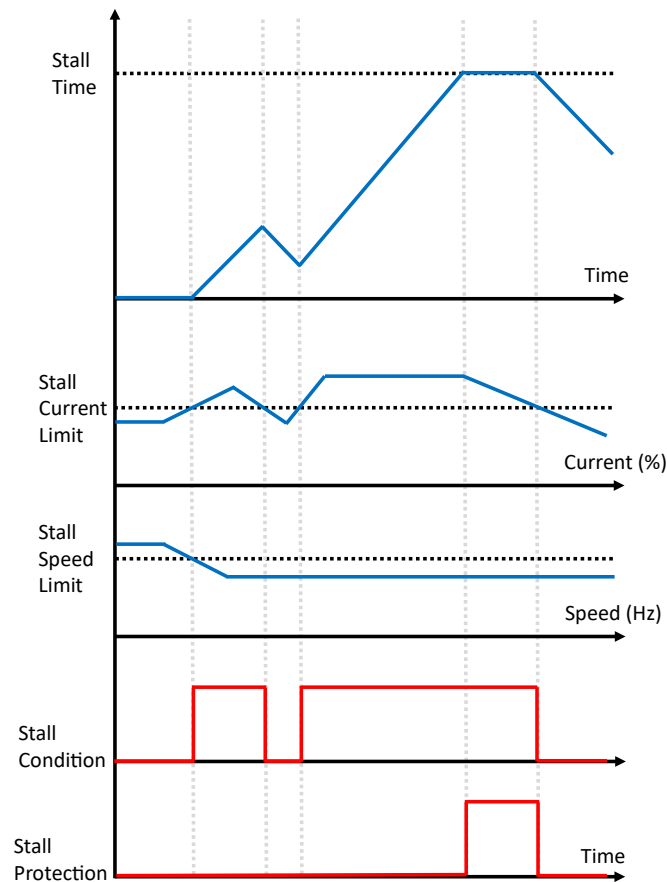

Figure 88: Operating principle of Motor Stall Protection.

P2.12.8.1 Stall Protection Response **No. 5083**

Select the drive response for stall protection event. For a stall state to occur the motor current must stay over the stall current limit, and the motor speed must stay below the stall speed limit, for the duration of the stall time.

No.	Name	Description
0	No response	-
1	Info	The drive will issue an info event.
3	Warning	The drive will issue a warning event.
9	Fault, ramp to coast	The drive will issue a fault event and ramp motor speed to zero before stopping modulation.
10	Fault, coast	The drive will issue a fault event and stop modulation immediately.

P2.12.8.2 Stall Current Limit **No. 5084**

Set the motor stall protection current limit. For a stall state to occur the motor current must exceed this limit.

P2.12.8.3 Stall Speed Limit **No. 5091**

Set the stall speed limit. For a stall state to occur the motor speed must decrease below this limit.

P2.12.8.4 Stall Time No. 5092

Set the time for the stall protection. The stall protection will act if the stall state (motor current is over current limit and motor speed is below speed limit) continues over the stall time.

7.3.12.9 Motor Overload

The motor overload protection allows the monitoring of motor current, torque, or power. As presented in the following figure for power, the monitored signal is compared to the overloading limits. A counter starts counting when the signal exceeds the minimum overload limit. An overload event is triggered if the counter reaches the overload time limit. The time limit is dynamically calculated based on the amount of overload. The greater the overload, the sooner the event will be triggered. Whenever the monitored signal goes below the minimum overload limit, the counter starts counting down. The event triggering level and time can be defined through the minimum and maximum overload levels and their corresponding maximum times.

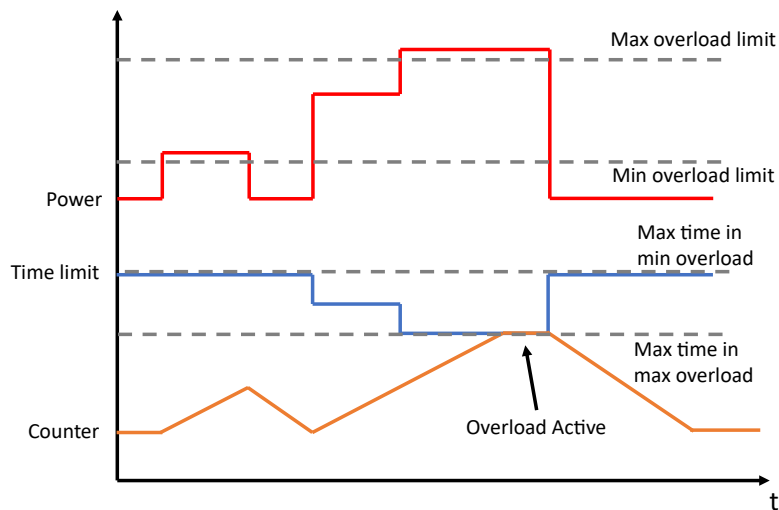

Figure 89: Operating principle of Motor Overload Protection.

P2.12.9.1 Overload Signal Selection No. 4565

Select the monitored signal for the Overload Protection.

No.	Name	Description
0	Not Used	-
1	Motor Current %	-
2	Motor Torque %	-
3	Motor Power %	-

P2.12.9.2 Max. Overload Limit No. 4566

Set the maximum Overload percentage limit. Above this limit, the Overload event is triggered using Overload Max.Lim. time parameter.

P2.12.9.3 Min. Overload Limit No. 4567

Set the minimum Overload percentage limit. Above this limit, the overload counter starts increasing. At this limit, the overload event is triggered using the **Overload Min. Lim.** time parameter.

P2.12.9.4 Max. Time at Max. Limit No. 4568

Set the time for Overload event triggering when the monitored signal becomes equal or greater than the maximum overload limit.

P2.12.9.5 Max. Time at Min. Limit No. 4569

Set the time for Overload event triggering when the monitored signal stays equal to the minimum overload limit.

P2.12.9.6 Overload Response No. 4586

Select the drive response for the Overload event.

No.	Name	Description
0	No response	-
1	Info	The drive will issue an info event.
3	Warning	The drive will issue a warning event.
9	Fault, ramp to coast	The drive will issue a fault event and ramp motor speed to zero before stopping modulation.
10	Fault, coast	The drive will issue a fault event and stop modulation immediately.

7.3.12.10 Inhibited Stop

The inhibited stop protection helps the drive to stop in case stopping becomes inhibited or prolonged. Stopping might become prolonged or even inhibited in winch/hoist applications, for example, if the drive hits the regenerative torque limit during stopping.

P2.12.10.1 Inhibited Stop Regen. Torque Response No. 3025

Select the response for the inhibited stop (regenerative torque limit) protection. Stopping might become inhibited or prolonged if the drive hits the regenerative torque limit during stop in winch/hoist applications, for example. With *Increase Torque Limit* the regenerative torque limit is increased to **Inhibited Stop Torque Limit Preset** if the stop takes longer than **Inhibited Stop Limit Increase Delay**. With *Force Brake Closing* the mechanical brake is closed if the stop takes longer than **Inhibited Stop Brake Closing Delay**. With *Increase Limit + Force Brake Closing* the torque limit is first increased to the set preset after the limit increase delay and the brake is closed after the brake closing delay.

No.	Name	Description
0	No action	-
1	Increase Torque Limit	Regenerative torque limit is increased to the level of parameter No. 3024 , if the stop takes longer than the time set with parameter No. 3022 .
2	Force Brake Closing	If the stop takes longer than the time set with parameter No. 3023 the mechanical brake is closed immediately.
3	Increase Limit + Force Brake Closing	Regenerative torque limit is increased to the level of parameter No. 3024 , if the stop takes longer than the time set with parameter No. 3022 .

No.	Name	Description
		if the drive is still not stopped the mechanical brake is closed after the time set with parameter No. 3023 .

P2.12.10.2 Inhibited Stop Torque Limit Preset **No. 3024**

Set the preset for the regenerative torque limit which is used when response has been set to *Increase Torque Limit* and stop is prolonged over the **Inhibited Stop Limit Increase Delay**.

P2.12.10.3 Inhibited Stop Limit Increase Delay **No. 3022**

Set the delay after which the regenerative torque limit is increased to set preset after drive stop command.

P2.12.10.4 Inhibited Stop Brake Closing Delay **No. 3023**

Set the delay after which the mechanical brake is closed after drive stop command. In case the response is set to *Increase Limit + Force Brake Closing* the brake closing counter is started after the torque limit has been increased.

P2.12.10.5 Inhibited Stop Overvoltage Response **No. 3026**

Select the response for the inhibited stop (overvoltage control limit) protection.

No.	Name	Description
0	No action	-
1	Force Coast	If the stop takes longer than the time set with parameter No. 3028 coast stop is forced.
2	Force Brake Closing	If the stop takes longer than the time set with parameter No. 3023 the mechanical brake is closed immediately.

P2.12.10.6 Inhibited Stop Undervoltage Response **No. 3027**

Select the response for the inhibited stop (undervoltage control limit) protection.

No.	Name	Description
0	No action	-
1	Force Coast	If the stop takes longer than the time set with parameter No. 3028 coast stop is forced.
2	Force Brake Closing	If the stop takes longer than the time set with parameter No. 3023 the mechanical brake is closed immediately.

P2.12.10.7 Inhibited Stop Coast Delay **No. 3028**

Set the delay after which coast stop is forced in case stop command is given and overvoltage or undervoltage limit controller is active.

7.3.12.11 Thermistor Monitoring

The thermistor monitoring function provides three input channels that can be connected to a Positive Temperature Coefficient (PTC) type sensor. After a threshold of 4 kilo-ohms is exceeded in the input, an event is triggered. The event response is configurable.

P2.12.11.1 Thermistor Monitoring Response **No. 5232**

Select the response to all thermistor monitoring events.

No.	Name	Description
0	No response	-
1	Info	The drive will issue an info event.
3	Warning	The drive will issue a warning event.
9	Fault, ramp to coast	The drive will issue a fault event and ramp motor speed to zero before stopping modulation.
10	Fault, coast	The drive will issue a fault event and stop modulation immediately.

P2.12.11.2 Thermistor Monitor 1 Input No. 1520

Select a thermistor input for thermistor monitor 1.

No.	Name	Description
0	None (False)	No input is selected. A virtual value of FALSE is applied.
1	None (True)	No input is selected. A virtual value of TRUE is applied.
*	Available thermistor input terminals	A dynamically generated selection of available thermistor input terminals is presented as an option. The specific set depends on the type and number of I/O options installed in the system.

P2.12.11.3 Thermistor Monitor 2 Input No. 1522

Select a thermistor input for thermistor monitor 2.

No.	Name	Description
0	None (False)	No input is selected. A virtual value of FALSE is applied.
1	None (True)	No input is selected. A virtual value of TRUE is applied.
*	Available thermistor input terminals	A dynamically generated selection of available thermistor input terminals is presented as an option. The specific set depends on the type and number of I/O options installed in the system.

P2.12.11.4 Thermistor Monitor 3 Input No. 1524

Select a thermistor input for thermistor monitor 3.

No.	Name	Description
0	None (False)	No input is selected. A virtual value of FALSE is applied.
1	None (True)	No input is selected. A virtual value of TRUE is applied.
*	Available thermistor input terminals	A dynamically generated selection of available thermistor input terminals is presented as an option. The specific set depends on the type and number of I/O options installed in the system.

7.3.12.12 Live Zero

This group contains parameters for selecting the drive's generic behavior if at least one of the analog inputs of the drive has gone below the set threshold value.

P2.12.12.1 Live Zero Active Output **No. 5185**

Select the output terminal for the indication of a live zero event being active.

No.	Name	Description
0	None	No output is selected.
*	Fieldbus status word 2 digital output bits	Fieldbus CTW2 digital output bits 0-15 will be presented as options.
*	Logic Digital I/O virtual terminals	Virtual digital inputs to the Logic Feature function blocks are presented as output options.
*	Available digital output and relay terminals	A dynamically generated selection of available digital output and relay terminals is presented as an option. The specific set depends on the type and number of I/O options installed in the system.

P2.12.12.2 Live Zero Response **No. 4555**

Select the drive response to a missing input signal (live zero).

No.	Name	Description
0	No response	-
1	Info	The drive will issue an info event.
3	Warning	The drive will issue a warning event.
9	Fault, ramp to coast	The drive will issue a fault event and ramp motor speed to zero before stopping modulation.
10	Fault, coast	The drive will issue a fault event and stop modulation immediately.

P2.12.12.3 Live Zero I/O Control Dependency **No. 4509**

Enable I/O control place dependency for the Live Zero event.

No.	Name	Description
0	Disabled	The live zero event will be activated according to live zero response (No. 4555) regardless of the active control place.
1	Enabled	The live zero event will be activated according to live zero response (No. 4555) only if I/O Control is the active control place.

7.3.12.13 Fieldbus Protections

This group contains parameters for setting responses, delays, and other settings for fieldbus related protections.

P2.12.13.1 Fieldbus Fault Response **No. 1303**

Select the behavior when a fieldbus fault occurs.

No.	Name	Description
0	No response	-
1	Info	The drive will issue an info event.

No.	Name	Description
3	Warning	The drive will issue a warning event.
9	Fault, ramp to coast	The drive will issue a fault event and ramp motor speed to zero before stopping modulation.
10	Fault, coast	The drive will issue a fault event and stop modulation immediately.

P2.12.13.2 Process Data Timeout Response **No. 5291**

Select the response to a process data timeout.

No.	Name	Description
0	No response	-
1	Info	The drive will issue an info event.
3	Warning	The drive will issue a warning event.
9	Fault, ramp to coast	The drive will issue a fault event and ramp motor speed to zero before stopping modulation.
10	Fault, coast	The drive will issue a fault event and stop modulation immediately.

P2.12.13.3 Process Data Timeout Delay **No. 1340**

Set a delay for the triggering of the Process Data Timeout event. If process data hasn't been updated within this delay time the event is triggered.

P2.12.13.4 Fieldbus Watchdog Response **No. 5244**

Select the drive response for the fieldbus watchdog event.

No.	Name	Description
0	No response	-
1	Info	The drive will issue an info event.
3	Warning	The drive will issue a warning event.
9	Fault, ramp to coast	The drive will issue a fault event and ramp motor speed to zero before stopping modulation.
10	Fault, coast	The drive will issue a fault event and stop modulation immediately.

P2.12.13.5 Fieldbus Watchdog Delay **No. 5245**

Set a delay for activating the fieldbus watchdog event.

P2.12.13.6 Fieldbus Watchdog Start Delay **No. 5246**

Set start-up delay time for activating the fieldbus watchdog event. The counter begins when the drive wakes up.

P2.12.13.7 FB Monitoring Control Place Dependency **No. 1338**

Set the control place dependency for fieldbus monitoring functions (Fieldbus Fault, Process Data Timeout and Fieldbus Watchdog). When enabled the monitoring functions are active only in fieldbus control place. When disabled the functions are active regardless of control place.

No.	Name	Description
0	Disabled	Fieldbus protection functions can activate regardless of the active control place.
1	Enabled	Fieldbus protection functions can activate only if Fieldbus is the active control place.

7.3.12.14 HMI Connection Loss

Selects the drive response for losing connection to MyDrive® Insight or the control panel while they are in control of the drive. Regardless of the response, the control will be released to the control place with the next highest control priority.

P2.12.14.1 HMI Connection Loss No. 5420

Select the response after lost connection to control panel or PC tool while they are in control. The timeout occurs after 5 s.

No.	Name	Description
0	No response	-
2	Info - Persistent	The drive will issue an info event that requires acknowledgment to reset.
4	Warning - Persistent	The drive will issue a warning event that requires acknowledgment to reset.
9	Fault, ramp to coast	The drive will issue a fault event and ramp motor speed to zero before stopping modulation.
10	Fault, coast	The drive will issue a fault event and stop modulation immediately.

7.3.12.15 Limit Supervision

Limit supervision is a feature for supervising drive readouts for too high or low values. Three readouts can be monitored simultaneously, and the supervision type, threshold, and hysteresis set accordingly. If the supervision acts a configurable event is triggered. It is also possible to map the supervision acted signal to a digital output.

NOTICE

The limit supervision 1 function is used internally to monitor motor shaft speed when **No. 1301 Fieldbus Profile** is set to *PROFIDrive® Standard Telegram 1*.

P2.12.15.1 Limit Supervision Signal Number 1 No. 5251

Set the parameter number of the variable to be monitored by Limit Supervision 1.

No.	Name	Description
0	None	-
9010	Motor Shaft Speed	-
1708	Motor Torque %	-
1707	Motor Power %	-
9001	Motor Current %	-
9044	DC-link Voltage	-

No.	Name	Description
1812	Motoring Torque Limit %	-
1813	Regenerative Torque Limit %	-
1814	Motoring Power Limit %	-
1815	Regenerative Power Limit %	-

P2.12.15.2 Limit Supervision 1 Type No. 5252

Select the type for Limit Supervision 1.

No.	Name	Description
0	No Action	The supervision is inactive.
1	Supervise Low Limit	The supervision activates if the monitored signal goes below the threshold.
2	Supervise High Limit	The supervision is activated if the monitored signal goes above the threshold.

P2.12.15.3 Limit Supervision 1 Threshold No. 5253

Set the value of the limit (Low/High limit) for Limit Supervision 1.

P2.12.15.4 Limit Supervision 1 Hysteresis No. 5255

Set the hysteresis value in % of the limit value for Limit Supervision 1.

P2.12.15.5 Limit Supervision Response 1 No. 5250

Select the drive response for the Limit Supervision 1 event.

No.	Name	Description
0	No response	-
1	Info	The drive will issue an info event.
3	Warning	The drive will issue a warning event.
9	Fault, ramp to coast	The drive will issue a fault event and ramp motor speed to zero before stopping modulation.
10	Fault, coast	The drive will issue a fault event and stop modulation immediately.

P2.12.15.6 Limit Supervision 1 Output No. 5254

Select the output terminal for the Limit Supervision 1 active - indication.

No.	Name	Description
0	None	No output is selected.
*	Fieldbus status word 2 digital output bits	Fieldbus CTW2 digital output bits 0-15 will be presented as options.
*	Logic Digital I/O virtual terminals	Virtual digital inputs to the Logic Feature function blocks are presented as output options.
*	Available digital output and relay terminals	A dynamically generated selection of available digital output and relay terminals is presented as an option. The specific set depends on the type and number of I/O options installed in the system.

P2.12.15.7 Limit Supervision Signal Number 2 No. 5257

Set the parameter number of the variable to be monitored by Limit Supervision 2. Choices are similar as parameter **No. 5251 Limit Supervision Signal Number 1**.

P2.12.15.8 Limit Supervision 2 Type No. 5258

Select the type for Limit Supervision 2.

No.	Name	Description
0	No Action	The supervision is inactive.
9010	Supervise Low Limit	The supervision activates if the monitored signal goes below the threshold.
1708	Supervise High Limit	The supervision is activated if the monitored signal goes above the threshold.

P2.12.15.9 Limit Supervision 2 Threshold No. 5259

Set the value of the limit (Low/High limit) for Limit Supervision 2.

P2.12.15.10 Limit Supervision 2 Hysteresis No. 5261

Set the hysteresis value in % of the limit value for Limit Supervision 2.

P2.12.15.11 Limit Supervision Response 2 No. 5256

Select the drive response for the Limit Supervision 2 event.

No.	Name	Description
0	No response	-
1	Info	The drive will issue an info event.
3	Warning	The drive will issue a warning event.
9	Fault, ramp to coast	The drive will issue a fault event and ramp motor speed to zero before stopping modulation.
10	Fault, coast	The drive will issue a fault event and stop modulation immediately.

P2.12.15.12 Limit Supervision Output 2 No. 5260

Select the output terminal for the Limit Supervision 2 active -indication.

No.	Name	Description
0	None	No output is selected.
*	Fieldbus status word 2 digital output bits	Fieldbus CTW2 digital output bits 0-15 will be presented as options.
*	Logic Digital I/O virtual terminals	Virtual digital inputs to the Logic Feature function blocks are presented as output options.
*	Available digital output and relay terminals	A dynamically generated selection of available digital output and relay terminals is presented as an option. The specific set depends on the type and number of I/O options installed in the system.

P2.12.15.13 Limit Supervision Signal Number 3 No. 5263

Set the parameter number of the variable to be monitored by Limit Supervision 3. Choices are similar as parameter **No. 5251 Limit Supervision Signal Number 1**.

P2.12.15.14 Limit Supervision 3 Type **No. 5264**

Select the type for Limit Supervision 3.

No.	Name	Description
0	No Action	The supervision is inactive.
9010	Supervise Low Limit	The supervision activates if the monitored signal goes below the threshold.
1708	Supervise High Limit	The supervision is activated if the monitored signal goes above the threshold.

P2.12.15.15 Limit Supervision 3 Threshold **No. 5265**

Set the value of the limit (Low/High limit) for Limit Supervision 3.

P2.12.15.16 Limit Supervision 3 Hysteresis **No. 5267**

Set the hysteresis value in % of the limit value for Limit Supervision 3.

P2.12.15.17 Limit Supervision Response 3 **No. 5262**

Select the drive response for the Limit Supervision 3 event.

No.	Name	Description
0	No response	-
1	Info	The drive will issue an info event.
3	Warning	The drive will issue a warning event.
9	Fault, ramp to coast	The drive will issue a fault event and ramp motor speed to zero before stopping modulation.
10	Fault, coast	The drive will issue a fault event and stop modulation immediately.

P2.12.15.18 Limit Supervision Output 3 **No. 5266**

Select the output terminal for the Limit Supervision 3 active -indication.

No.	Name	Description
0	None	No output is selected.
*	Fieldbus status word 2 digital output bits	Fieldbus CTW2 digital output bits 0-15 will be presented as options.
*	Logic Digital I/O virtual terminals	Virtual digital inputs to the Logic Feature function blocks are presented as output options.
*	Available digital output and relay terminals	A dynamically generated selection of available digital output and relay terminals is presented as an option. The specific set depends on the type and number of I/O options installed in the system.

7.3.12.16 Overcurrent Protection

The overcurrent protection feature can be used to safeguard external devices from excessive current. It is particularly useful in installations where the current rating of the drive exceeds that of other connected equipment.

P2.12.16.1 Overcurrent Protection Limit No. 2368

Set the limit for overcurrent protection in % of motor nominal current. At this level the drive disables the inverter, makes a coast stop, and issues a fault to protect the motor. This limit can be used, for example, to protect PM motors from demagnetization caused by too high peak currents. If set to 0, the function is disabled.

NOTICE

This parameter can never be set above the internal hardware-dependent overcurrent limits of the drive.
--

7.3.13 Mechanical Brake Control

The Mechanical Brake Control feature controls the opening and closing of a mechanical brake and ensures a smooth transition of load between the drive and the brake. The mechanical brake holds the load when the drive is not running. Mechanical brake control works with all control modes: speed, torque, and power. Both unidirectional and bidirectional loads are supported.

The mechanical brake control supports the following functions:

- Control of the brake through a digital output or relay. Select the output terminal with parameter **No. 3007**.
- Two channels for brake feedback to offer further protection against unintended behavior resulting from a broken cable. Select the input terminals with parameters **No. 3010** and **No. 3011**. Configurations of no feedback at all, one open or close signal or both signals are supported.
- Monitoring of mechanical braking feedback throughout the complete cycle with configurable timeouts. This helps to protect the mechanical brake, especially if more drives are connected to the same shaft. Configure the timeouts with parameters **No. 3006**, **No. 3003**, **No. 3004**, and **No. 3043**.
- Additionally configure a response to a loss of feedback with parameter **No. 3042**.
- No ramp-up until feedback confirms that mechanical brake is open.
- Improved load control at stop. If the value of the delay is too low, a warning is activated, and the torque is not allowed to ramp down.
- Configurable load-bearing transition from the brake to the motor. Release Bandwidth can be increased to minimize the movement with parameter **No. 3015**.
- Timing and direction of applied torque for engaging or disengaging mechanical brake. Configure with parameters **No. 3000**, **No. 3001**, **No. 3005**.
- A selection for closing the brake immediately or after ramping to zero during faults. Configure with parameter **No. 3040**.
- A DC-link overvoltage protection. Exceeding a set voltage level (parameter **No. 3014**) will close the brake immediately, after which the modulation will be ramped down to try and protect the DC-link capacitors by burning the energy in the motor.
- Brake slip detection alerts if the motor axle rotates more than the set slip limit when the brake is closed.

NOTICE

Mechanical Brake Control requires the use of the FVC+ motor control principle. See parameter No. 2503 .
--

Drive Start with Mechanical Brake

- The motor must be primed by gradually applying a holding torque against the brake so that the torque step is minimized when the brake is released.
- After the priming torque is applied and priming time has passed, the brake is released.
- There is a physical delay between electrical release of brake and physical release of brake. This is referred to as brake release time and is set via the parameter Brake Release Time. When this happens, load is shifted from mechanical brake to the motor instantaneously.

Drive Stop with Mechanical Brake

- When stopping, the mechanical brake control monitors the motor speed when the motor is ramping down towards zero speed.
- When the brake closing speed is achieved, brake closing signal is sent. The speed continues to ramp down to zero where it is held at while the brake physically closes.
- When closed, torque is ramped down to zero, gradually shifting load from motor to brake.

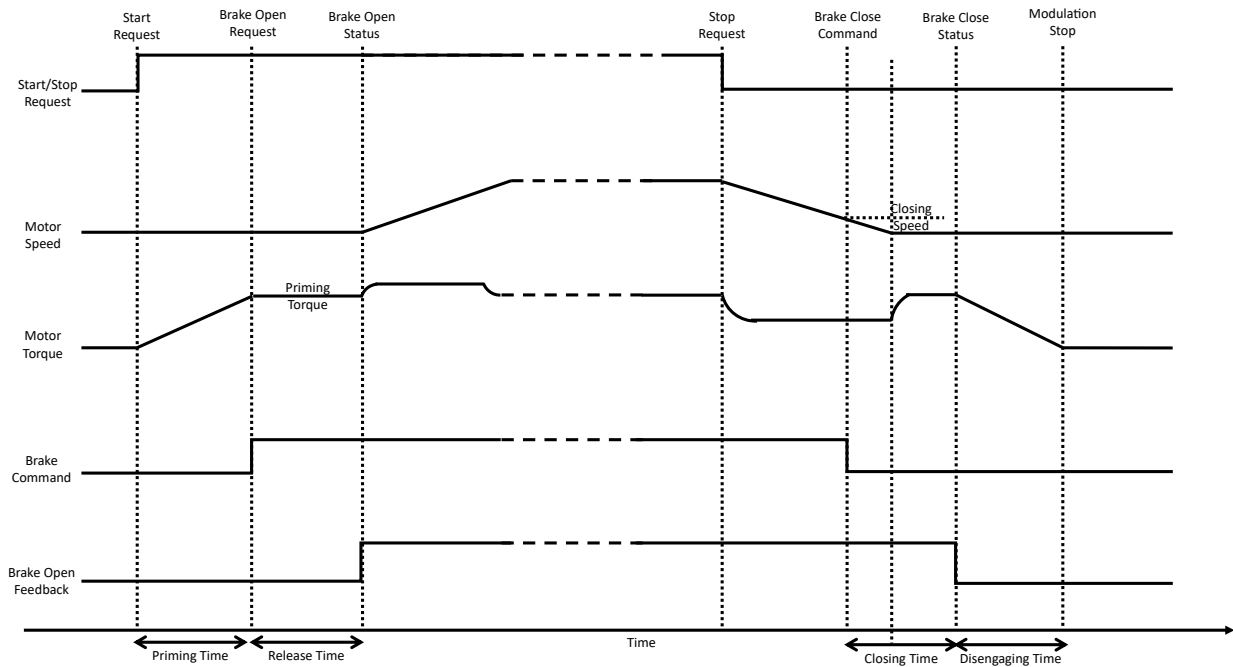

Figure 90: Operation principle of mechanical brake control.

P2.13.1 Brake Output No. 3007

Select the output terminal for controlling the mechanical brake. The whole feature is disabled if this parameter is set to "None".

No.	Name	Description
0	None	No output is selected.
*	Fieldbus status word 2 digital output bits	Fieldbus CTW2 digital output bits 0-15 will be presented as options.
*	Logic Digital I/O virtual terminals	Virtual digital inputs to the Logic Feature function blocks are presented as output options.

No.	Name	Description
*	Available digital output and relay terminals	A dynamically generated selection of available digital output and relay terminals is presented as an option. The specific set depends on the type and number of I/O options installed in the system.

NOTICE

This parameter cannot be edited when the drive is running.

P2.13.2 Brake Priming Torque No. 3012

Set the torque to be build up against the mechanical brake during priming before releasing the brake.

P2.13.3 Brake Priming Direction No. 3001

Select the direction of the applied torque during priming before releasing the brake.

No.	Name	Description
0	Clockwise	A positive priming torque is applied in relation to the drive's electrical rotation orientation.
1	Counterclockwise	A negative priming torque is applied in relation to the drive's electrical rotation orientation.
2	Reference direction	The sign of the priming torque matches the sign of the speed reference.

P2.13.4 Brake Priming Time No. 3000

Set the priming time duration.

P2.13.5 Brake Priming Timeout No. 3006

Set the time after which a warning will be generated if priming cannot be finalized.

P2.13.6 Brake Release Time No. 3003

Set the time it takes for the mechanical brake to open and to release the load. This time is counted after the brake priming has finished. If feedback of an open brake is not received within this time the drive will issue a "Brake Feedback Timeout" warning.

P2.13.7 Brake Open Input No. 3010

Select the input terminal for an open indication signal from the mechanical brake.

No.	Name	Description
0	None (False)	No input is selected. A virtual value of FALSE is applied.
1	None (True)	No input is selected. A virtual value of TRUE is applied.
*	Fieldbus control word 1/2 digital input bits	Fieldbus CTW1 digital input bits 12-15 and CTW2 digital input bits 0-15 will be presented as options.
*	Logic Digital I/O virtual terminals	Virtual digital outputs from the Logic Feature function blocks are presented as input options.
*	Available digital input terminals	A dynamically generated selection of available digital input terminals is presented as an option. The specific set depends on the type and number of I/O options installed in the system.

P2.13.8 Brake Hover Time No. 3013

Set the hover time. Hover time is the duration where the drive holds the load before the mechanical brake closes to allow an instant restart. Use this parameter to delay the closing of the brake if necessary. The time starts counting after the motor goes below the closing speed in a stop sequence.

P2.13.9 Brake Closing Speed No. 3002

Set the speed at which the brake gets active (control terminal goes low).

P2.13.10 Brake Close Time No. 3004

Set the time it takes for the mechanical brake to close and to hold the load. This time is counted after the brake hover time has finished. If feedback of a closed brake is not received within this time the drive will issue a "Brake Feedback Timeout" warning.

P2.13.11 Brake Closed Input No. 3011

Select the input terminal for a closed signal from the mechanical brake.

No.	Name	Description
0	None (False)	No input is selected. A virtual value of FALSE is applied.
1	None (True)	No input is selected. A virtual value of TRUE is applied.
*	Fieldbus control word 1/2 digital input bits	Fieldbus CTW1 digital input bits 12-15 and CTW2 digital input bits 0-15 will be presented as options.
*	Logic Digital I/O virtual terminals	Virtual digital outputs from the Logic Feature function blocks are presented as input options.
*	Available digital input terminals	A dynamically generated selection of available digital input terminals is presented as an option. The specific set depends on the type and number of I/O options installed in the system.

P2.13.12 Brake Disengaging Time No. 3005

Set the duration from the brake is closed to the holding torque is released. Use this parameter to add a safety margin for holding the load with both the brake and the motor.

P2.13.13 Brake Release Bandwidth No. 3015

Set the release control bandwidth. Use this parameter to enable the so called "rollback control". This parameter can fine tune the speed control bandwidth by scaling it. Leave at 100 % to disable rollback control.

P2.13.14 Brake Control Active Output No. 5187

Select the output for the Brake Control Active indication. Use this for indications of the brake control actively influencing the brake (priming, releasing, hovering, or closing).

No.	Name	Description
0	None	No output is selected.
*	Fieldbus status word 2 digital output bits	Fieldbus CTW2 digital output bits 0-15 will be presented as options.
*	Logic Digital I/O virtual terminals	Virtual digital inputs to the Logic Feature function blocks are presented as output options.
*	Available digital output and relay terminals	A dynamically generated selection of available digital output

No.	Name	Description
		and relay terminals is presented as an option. The specific set depends on the type and number of I/O options installed in the system.

P2.13.15 Brake Close Immediately On Fault **No. 3040**

Enables immediate brake closure in case of a fault. Some faults will ramp to zero - if not enabled brake will wait for speed to be low enough before closing.

No.	Name	Description
0	Disabled	During fault, the brake is closed only after the fault stop sequence, which might include ramping the motor speed down to zero before closing the brake.
1	Enabled	The brake is immediately closed during all faults, regardless of their stop settings.

P2.13.16 Brake Closing DC Link Protection **No. 3019**

Enables protection against high DC link voltage, likely caused by high back EMF of the controlled motor. The drive DC capacitor is protected by closing the mechanical brake and stopping the drive in case the DC link voltage increases over its settable limit for the settable delay. Recommended usage hoist/winch applications with permanent magnet motors.

No.	Name	Description
0	Disabled	The brake will not be closed due to high DC-link voltages.
1	Enabled	The brake is closed if the DC-link voltage reaches the limit specified with parameter No. 3014 .

P2.13.17 Brake Closing DC Link Limit **No. 3014**

Set the voltage limit in % of nominal DC link voltage for the brake closing protection due to high DC link voltage. The protection will act if the DC link voltage is above this limit for the set delay.

P2.13.18 Brake Closing DC Link Delay **No. 3018**

Set the delay in milliseconds for the brake closing protection due to high DC link voltage. The protection will act if the DC link voltage is above its limit for the set delay.

P2.13.19 Brake Feedback Error Response **No. 3042**

Select a response for mechanical brake feedback signals changing too late or being in wrong states when the drive is running. Warnings are always issued while the drive is not running. The error is triggered if brake open or close feedback(s) differ from the command signal. The response is issued if the error persists for the time set with parameter **No. 3043**.

No.	Name	Description
0	No response	-
1	Info	The drive will issue an info event.
3	Warning	The drive will issue a warning event.
9	Fault, ramp to coast	The drive will issue a fault event and ramp motor speed to zero before stopping modulation.
10	Fault, coast	The drive will issue a fault event and stop modulation immediately.

P2.13.20 Brake Feedback Error Time **No. 3043**

Set the monitoring time for the brake feedback error. The error is triggered if brake open or close feedback(s) differ from the command signal for the set time. The monitoring is started when the brake open or close command is sent or the feedback signal(s) change status.

P2.13.21 Brake Slip Detection Response **No. 3031**

Select the response to a detected brake slip. A brake slip is detected if the motor axle rotates more than the set slip limit when the brake is closed.

No.	Name	Description
0	Off	Slip detection is disabled.
1	Warning	The drive will issue a warning event.

P2.13.22 Brake Slip Limit **No. 3030**

Set the angle for maximum allowed brake slip.

7.3.14 Motor Breaker Control

The motor breaker control feature makes it possible to open, close, and monitor a breaker installed between the drive and the motor. The breaker can be either automatically controlled by the drive, or manually controlled through the drive. Both one-wire and two-wire control and feedback signal schemes are supported.

The sequence diagram of the following figure shows an example of operating the breaker control in the Automatic Mode, with Opening Condition set to "Stop". In the depicted sequence, the run request (start command) is given, and the breaker closing command follows immediately. After receiving the breaker closed feedback, the drive starts running. When the run request is removed (stop command), the drive ramps down, stops running and the breaker open command follows.

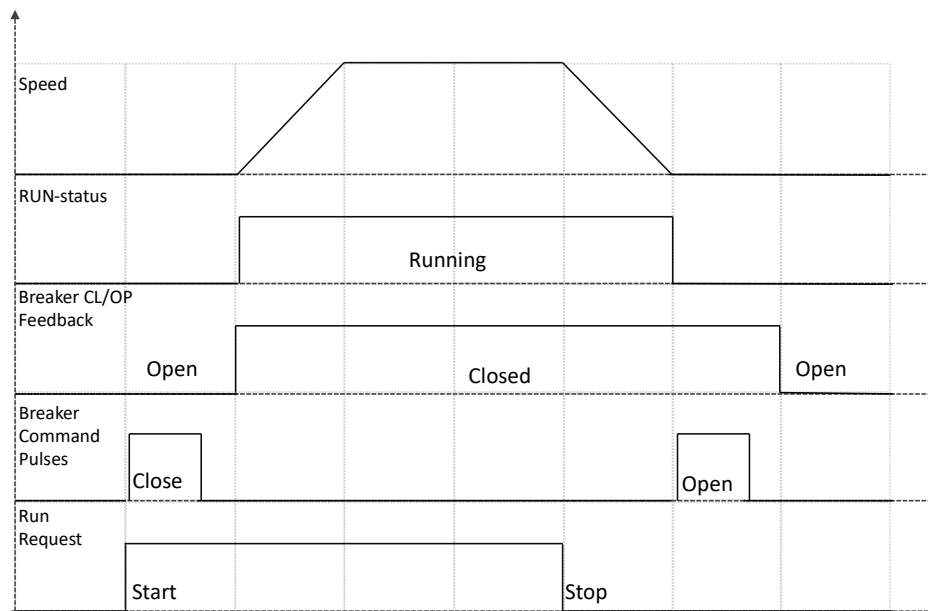

Figure 91: Basic sequence diagram of motor breaker control in Automatic Mode.

Enabling Breaker Control:

With parameter **No. 4735**, a digital input terminal can be defined for enabling the breaker control. When enabled, command signals can be sent out, run command is interlocked based on breaker state, feedback signals are monitored, and supervision events can be generated. When disabled, the breaker control behaves according to parameter **No. 4736**, where the options are to either ignore this feature completely or interlock the start command.

Commands:

Parameter **No. 4702** defines whether commands are given with only one common or two separate open and close signals. Parameter **No. 4701** selects whether breaker closing and opening commands are given manually using digital input signals configured with parameters **No. 4705** and **No. 4706**, or automatically based on drive start and stop commands. In addition to the digital inputs, the manual close and open commands can be given via the FB PCD Operation Control Word (**No. 4564**), in which the bit 0 is used for the open command and bit 1 for the closing command. Furthermore, breaker opening conditions can be defined for the automatic mode with parameter **No. 4704**. The command signals themselves are relayed via terminals defined with parameters **No. 4709** and **No. 4710**.

Feedback signals:

Parameter **No. 4703** defines whether feedback signals are given at all, with only one common or two separate opened and closed signals. Then parameters **No. 4707** and **No. 4708** can be used to select which digital input terminals will be used for these signals.

The states of the feedback signals are constantly monitored and compared to the state of the breaker control and cross-referenced to each other. If discrepancies are identified an event can be triggered, the response of which can be configured with parameter **No. 4712**.

P2.14.1 Breaker Manual Close Input **No. 4705**

Select the digital input terminal for the manual breaker closing command. Note: this terminal is used state-based for both closing and opening commands when Command Signal Mode is set to *Common*

CL/OP (state). This same terminal is used for a pulse-based close command when the Command Signal Mode is set to *Separate CL/OP (Pulse)*.

No.	Name	Description
0	None (False)	No input is selected. A virtual value of FALSE is applied.
1	None (True)	No input is selected. A virtual value of TRUE is applied.
*	Fieldbus control word 1/2 digital input bits	Fieldbus CTW1 digital input bits 12-15 and CTW2 digital input bits 0-15 will be presented as options.
*	Logic Digital I/O virtual terminals	Virtual digital outputs from the Logic Feature function blocks are presented as input options.
*	Available digital input terminals	A dynamically generated selection of available digital input terminals is presented as an option. The specific set depends on the type and number of I/O options installed in the system.

P2.14.2 Breaker Manual Open Input No. 4706

Select the digital input terminal for the manual breaker opening command. Note: this terminal is used only when Command Signal Mode is set to *Separate CL/OP (Pulse)*.

No.	Name	Description
0	None (False)	No input is selected. A virtual value of FALSE is applied.
1	None (True)	No input is selected. A virtual value of TRUE is applied.
*	Fieldbus control word 1/2 digital input bits	Fieldbus CTW1 digital input bits 12-15 and CTW2 digital input bits 0-15 will be presented as options.
*	Logic Digital I/O virtual terminals	Virtual digital outputs from the Logic Feature function blocks are presented as input options.
*	Available digital input terminals	A dynamically generated selection of available digital input terminals is presented as an option. The specific set depends on the type and number of I/O options installed in the system.

P2.14.3 Breaker Close Feedback Input No. 4707

Select the digital input terminal for the breaker close-status feedback. Note: this terminal is used for both closed- and open-status when Feedback Signal Mode is set to *Common CL/OP Signal*. This same terminal is used for close status only, when the Feedback Signal Mode is set to *Separate CL/OP Signals*.

No.	Name	Description
0	None (False)	No input is selected. A virtual value of FALSE is applied.
1	None (True)	No input is selected. A virtual value of TRUE is applied.
*	Fieldbus control word 1/2 digital input bits	Fieldbus CTW1 digital input bits 12-15 and CTW2 digital input bits 0-15 will be presented as options.
*	Logic Digital I/O virtual terminals	Virtual digital outputs from the Logic Feature function blocks are presented as input options.
*	Available digital input terminals	A dynamically generated selection of available digital input terminals is presented as an option. The specific set depends on the type and number of I/O options installed in the system.

P2.14.4 Breaker Open Feedback Input No. 4708

Select the digital input terminal for the breaker open-status feedback. Note: this terminal is used only when Feedback Signal Mode is set to *Separate CL/OP Signals*.

No.	Name	Description
0	None (False)	No input is selected. A virtual value of FALSE is applied.
1	None (True)	No input is selected. A virtual value of TRUE is applied.
*	Fieldbus control word 1/2 digital input bits	Fieldbus CTW1 digital input bits 12-15 and CTW2 digital input bits 0-15 will be presented as options.
*	Logic Digital I/O virtual terminals	Virtual digital outputs from the Logic Feature function blocks are presented as input options.
*	Available digital input terminals	A dynamically generated selection of available digital input terminals is presented as an option. The specific set depends on the type and number of I/O options installed in the system.

P2.14.5 Breaker Close Output No. 4709

Select the digital output terminal for the breaker closing command. Note: this terminal is used state-based for both closing and opening commands when Command Signal Mode is set to *Common CL/OP (state)*. This same terminal is used for a pulse-based close command when the Command Signal Mode is set to *Separate CL/OP (Pulse)*. A 1 second pulse is used.

No.	Name	Description
0	None	No output is selected.
*	Fieldbus status word 2 digital output bits	Fieldbus CTW2 digital output bits 0-15 will be presented as options.
*	Logic Digital I/O virtual terminals	Virtual digital inputs to the Logic Feature function blocks are presented as output options.
*	Available digital output and relay terminals	A dynamically generated selection of available digital output and relay terminals is presented as an option. The specific set depends on the type and number of I/O options installed in the system.

P2.14.6 Breaker Open Output No. 4710

Select the digital output terminal for the breaker opening command. Note: this terminal is used only when Command Signal Mode is set to *Separate CL/OP (Pulse)*. A 1 second pulse is used.

No.	Name	Description
0	None	No output is selected.
*	Fieldbus status word 2 digital output bits	Fieldbus CTW2 digital output bits 0-15 will be presented as options.
*	Logic Digital I/O virtual terminals	Virtual digital inputs to the Logic Feature function blocks are presented as output options.
*	Available digital output and relay terminals	A dynamically generated selection of available digital output and relay terminals is presented as an option. The specific set depends on the type and number of I/O options installed in the system.

P2.14.7 Breaker Control Enable Input No. 4735

Select the input terminal for enabling motor breaker control.

No.	Name	Description
0	None (False)	No input is selected. A virtual value of FALSE is applied.
1	None (True)	No input is selected. A virtual value of TRUE is applied.
*	Fieldbus control word 1/2 digital input bits	Fieldbus CTW1 digital input bits 12-15 and CTW2 digital input bits 0-15 will be presented as options.
*	Logic Digital I/O virtual terminals	Virtual digital outputs from the Logic Feature function blocks are presented as input options.
*	Available digital input terminals	A dynamically generated selection of available digital input terminals is presented as an option. The specific set depends on the type and number of I/O options installed in the system.

P2.14.8 Automatic/Manual Breaker Control No. 4701

Select between automatic or manual breaker control. In automatic control, the drive will command the breaker based on drive status, breaker status, and settings. In manual mode, opening and closing commands can be issued via I/O or FB. The drive will allow running based on breaker status and can also block breaker opening based on running status.

No.	Name	Description
0	Automatic Commands	<p>The drive will command the breaker based on drive status, breaker status, and settings.</p> <p>Closing: After receiving a start-command, the drive will issue a close command to an open breaker. The drive will wait to receive a closed status from the breaker, before running. When the status is received, the drive will start running.</p> <p>Opening: Check the behavior from the description of parameter No. 4704.</p>
1	Manual Commands	<p>Opening and closing commands can be issued via the Manual Input signals.</p> <p>Closing: The breaker can be freely closed while the drive is not running. The drive cannot be put to run state before the breaker is closed. (Interlocking) Note: a start command is only acknowledged if it is given once the breaker is already closed.</p> <p>Opening: The breaker can be freely opened while the drive is not running. The breaker cannot be opened while the drive is in run-state. With a state-based Command Signal Mode, if an open command is given while the drive is running, it is queued/reserved until the drive stops running.</p>

P2.14.9 Breaker Command Signal Mode**No. 4702**

Select the breaker Command Signal Mode. This setting applies to both automatic and manual control.

No.	Name	Description
0	No Commands	No commands are giving by or through the drive. The drive can still monitor the breaker feedback. A start command cannot be given unless the breaker is closed.
1	Common CL/OP (state)	<p>The drive will use only one common signal to control the breaker. The signal is state based.</p> <p>The output signal is relayed through the close terminal only.</p> <p>The manual command input is received through the close terminal only.</p> <p>By default, an active signal is interpreted as a constant close command.</p> <p>By default, an inactive signal is interpreted as a constant open command.</p>
2	Separate CL/OP (pulse)	<p>The drive will use two separate signals to control the breaker. These signals are pulse-based.</p> <p>The signals use their own dedicated terminals for both the outputs and manual command inputs.</p> <p>The drive will send one (1) second pulses to the outputs.</p> <p>The drive will monitor the rising edges of the manual input commands.</p> <p>If both manual input signals are active, the open command will take precedence.</p>

P2.14.10 Breaker Feedback Signal Mode**No. 4703**

Select the breaker feedback signal mode. The feedback signal is used for interlocking the run-command and supervision the breaker status.

No.	Name	Description
0	No Feedback	<p>No feedback is used.</p> <p>The drive will assume the breaker to be open or closed based on given start, stop and breaker commands. If no commands are used, the drive behaves as if breaker control would be disabled.</p>
1	Common CL/OP Signal	<p>The drive will use only the close feedback as a common signal for breaker feedback.</p> <p>By default, the breaker is seen as closed if the signal is active.</p> <p>By default, the breaker is seen as open if the signal is active.</p>
2	Separate CL/OP Signals	<p>The drive will use both the close and open feedback signals for breaker feedback.</p> <p>The breaker is seen closed when the closed signal is active and opened signal is inactive.</p> <p>The breaker is seen opened if the closed signal is inactive or the opened signal is active.</p>

P2.14.11 Breaker Opening Condition**No. 4704**

Set the condition for opening the breaker while operating in the automatic control mode. Note: this parameter does not take any effect in the manual control mode.

No.	Name	Description
0	Stop	The drive will open the breaker after stopping of modulation. If the drive ramps the motor speed down, the drive will wait for the ramp to finish before opening the breaker.
1	Fault	The drive will open the breaker after stopping of modulation. If the drive ramps the motor speed down, the drive will wait for the ramp to finish before opening the breaker.
2	Quick Stop	The drive will open the breaker only after a Quick Stop request. If the drive ramps the motor speed down, the drive will wait for the ramp to finish before opening the breaker.
3	Never Open	Once the breaker is closed, the drive will not issue a breaker opening command. To open the breaker, change the opening mode, set the control mode to manual and issue an opening command, or open the breaker externally.

P2.14.12 Breaker Monitor Delay No. 4711

Set a delay for generating a supervision event. This event is activated when breaker feedback signals do not match with given breaker commands or if the two feedback signals do not match with each other. Set the delay slightly greater than the associated action time and feedback delays for opening and closing the breaker.

P2.14.13 Breaker Monitor Response No. 4712

Select the drive's response to the breaker supervision event. This event can be used to react to opening or closing failures, or sudden loss of a feedback signal.

No.	Name	Description
0	No response	-
1	Info	The drive will issue an info event.
3	Warning	The drive will issue a warning event.
9	Fault, ramp to coast	The drive will issue a fault event and ramp motor speed to zero before stopping modulation.
10	Fault, coast	The drive will issue a fault event and stop modulation immediately.

P2.14.14 Breaker Control Disable Mode No. 4736

Select how motor breaker control behaves when the enabling signal is inactive.

No.	Name	Description
0	Disable Breaker Control	Breaker control is completely disabled, and it will not influence drive interlocking or running.
1	Interlock	The breaker control will apply its own interlocking signals blocking the drive from running.

7.3.15 Output Filter

This group contains parameters for configuring an optional output filter connected between the drive and the motor. These filters can provide motor protection and noise reduction benefits for example. If

an output filter is used, the following parameters should be set to adjust motor and drive control functions to take the filter into account.

P2.15.1 Output Filter Type No. 5501

Select the output filter type.

No.	Name	Description
0	None	
1	Sine-wave Filter	

P2.15.2 Filter Capacitance No. 5502

Set the capacitance of the output filter.

P2.15.3 Filter Inductance No. 5503

Set the inductance of the output filter.

7.3.16 Inching

Inching is used for operating the motor for periods with a specific inching reference. A typical example for using inching, is during manual operation of the drive for maintenance or service.

For inching, it is possible to configure two different references with parameters **No. 1082, No. 1085**. These references can then be applied by first enabling inching with a digital signal (signal selected with parameter **No. 1080**), and then applying either of the activation inputs (signal selected with parameters **No. 1084, No. 1086**). Alternatively inching can be activated via fieldbus, depending on the selected fieldbus profile.

Note that when active, inching will override speed ramp settings. The inching ramp time applies to both acceleration and deceleration, and S-ramp settings are disabled.

Depending on the application's needs and required conditions, three different inching modes are supported:

- **Slow Down mode:** This mode provides the ability to run in a creep mode slowing down to a desired lower speed. The motor must be running, and the inching reference must be lower than the current reference before this mode can be activated.
- **Jogging mode:** This mode provides the ability to start the motor with a fixed reference using a single input signal. For this mode to work, the motor must be stopped prior to activating inching.
- **Override mode:** This mode provides the ability to run with a fixed reference overriding both the start signal and the reference. In this mode, the motor is either started with a fixed reference or the current reference is overridden with the inching reference.

P2.16.1 Inching Mode No. 1081

Select the inching mode. Inching is used for operating the motor for periods with a specific inching reference.

No.	Name	Description
0	Slow Down Mode	While activated inching is only applied if the requested inching reference is lower than the current motor speed.
1	Jogging Mode	While the drive is not already running, inching can be activated to start the drive and override the reference.
2	Override Mode	While active, inching can start the drive and override the reference.

P2.16.2 Enable Inching Input No. 1080

Select a terminal to enable inching. Activating this signal can start the drive depending on the selected inching mode.

No.	Name	Description
0	None (False)	No input is selected. A virtual value of FALSE is applied.
1	None (True)	No input is selected. A virtual value of TRUE is applied.
*	Fieldbus control word 1/2 digital input bits	Fieldbus CTW1 digital input bits 12-15 and CTW2 digital input bits 0-15 will be presented as options.
*	Logic Digital I/O virtual terminals	Virtual digital outputs from the Logic Feature function blocks are presented as input options.
*	Available digital input terminals	A dynamically generated selection of available digital input terminals is presented as an option. The specific set depends on the type and number of I/O options installed in the system.

P2.16.3 Inching Ramp Time No. 1083

Set the ramp time for inching. This ramp time overrides the active speed ramp settings whenever inching is activated. The ramp time applies both to acceleration and deceleration. S-ramp settings are also disabled.

P2.16.4 Inching Reference 1 No. 1082

Set reference 1 for inching.

P2.16.5 Inching Activate Input 1 No. 1084

Select the terminal to inching with reference 1. Enable inching input must be active.

No.	Name	Description
0	None (False)	No input is selected. A virtual value of FALSE is applied.
1	None (True)	No input is selected. A virtual value of TRUE is applied.
*	Fieldbus control word 1/2 digital input bits	Fieldbus CTW1 digital input bits 12-15 and CTW2 digital input bits 0-15 will be presented as options.
*	Logic Digital I/O virtual terminals	Virtual digital outputs from the Logic Feature function blocks re presented as input options.
*	Available digital input terminals	A dynamically generated selection of available digital input terminals is presented as an option. The specific set depends on the type and number of I/O options installed in the system.

P2.16.6 Inching Reference 2 No. 1085

Set reference 2 for inching.

P2.16.7 Inching Activate Input 2 No. 1086

Select the terminal to inching with reference 2. Enable inching input must be active.

No.	Name	Description
0	None (False)	No input is selected. A virtual value of FALSE is applied.
1	None (True)	No input is selected. A virtual value of TRUE is applied.
*	Fieldbus control word 1/2 digital input bits	Fieldbus CTW1 digital input bits 12-15 and CTW2 digital input bits 0-15 will be presented as options.
*	Logic Digital I/O virtual terminals	Virtual digital outputs from the Logic Feature function blocks are presented as input options.
*	Available digital input terminals	A dynamically generated selection of available digital input terminals is presented as an option. The specific set depends on the type and number of I/O options installed in the system.

P2.16.8 Inching Active Output No. 1087

Select the output terminal or status bit indicating that inching is active.

No.	Name	Description
0	None	No output is selected.
*	Fieldbus status word 2 digital output bits	Fieldbus CTW2 digital output bits 0-15 will be presented as options.
*	Logic Digital I/O virtual terminals	Virtual digital inputs to the Logic Feature function blocks are presented as output options.
*	Available digital output and relay terminals	A dynamically generated selection of available digital output and relay terminals is presented as an option. The specific set depends on the type and number of I/O options installed in the system.

7.3.17 Advanced Harmonic Filter

This group contains advanced harmonic filter related settings. The advanced harmonic filter is an optional band pass filter connected between the mains and the rectifier in a frequency converter drive to give better total harmonic distortion performance.

NOTICE

This group is only visible in drives with integrated rectifier units.

P2.17.1 Advanced Harmonic Filter No. 3410

Select if the Advanced Harmonic Filter is connected to the drive.

No.	Name	Description
0	Disabled	
1	Enabled	

P2.17.2 Capacitor Disconnect Output No. 3412

Select the output terminal for disconnecting the capacitor. If this parameter is configured, the drive disconnects the capacitors at standstill.

No.	Name	Description
0	None	No output is selected.
*	Fieldbus status word 2 digital output bits	Fieldbus CTW2 digital output bits 0-15 will be presented as options.
*	Logic Digital I/O virtual terminals	Virtual digital inputs to the Logic Feature function blocks are presented as output options.
*	Available digital output and relay terminals	A dynamically generated selection of available digital output and relay terminals is presented as an option. The specific set depends on the type and number of I/O options installed in the system.

P2.17.3 Thermal Switch Response No. 3413

Select which function is activated if the thermal input indicates too high a temperature.

No.	Name	Description
0	Fault, ramp to coast	
1	Derate	

P2.17.4 Thermal Switch Input No. 3414

Select the digital input terminal for the thermal switch.

No.	Name	Description
0	None (False)	No input is selected. A virtual value of FALSE is applied.
1	None (True)	No input is selected. A virtual value of TRUE is applied.
*	Fieldbus control word 1/2 digital input bits	Fieldbus CTW1 digital input bits 12-15 and CTW2 digital input bits 0-15 will be presented as options.
*	Logic Digital I/O virtual terminals	Virtual digital outputs from the Logic Feature function blocks are presented as input options.
*	Available digital input terminals	A dynamically generated selection of available digital input terminals is presented as an option. The specific set depends on the type and number of I/O options installed in the system.

7.3.18 Master Follower

This group contains master follower related settings.

NOTICE

The Master Follower feature is still under development. Do not touch the parameters of this group.

P2.18.1 Master Follower Mode Input No. 5752

Select the input terminal for selecting the Master Follower Mode between modes 1 and 2.

No.	Name	Description
0	None (False)	No input is selected. A virtual value of FALSE is applied.
1	None (True)	No input is selected. A virtual value of TRUE is applied.
*	Fieldbus control word 1/2 digital input bits	Fieldbus CTW1 digital input bits 12-15 and CTW2 digital input bits 0-15 will be presented as options.
*	Logic Digital I/O virtual terminals	Virtual digital outputs from the Logic Feature function blocks are presented as input options.
*	Available digital input terminals	A dynamically generated selection of available digital input terminals is presented as an option. The specific set depends on the type and number of I/O options installed in the system.

P2.18.2 Master Follower Mode 1 No. 5536

Set the master-follower mode 1. This mode is used when No. 5715 Master Follower Mode Input is deactivated (false).

No.	Name	Description
0	Single Drive	Drive operates as a single drive without master-follower configuration.
1	Master Drive	Drive operates as the master drive in a master-follower configuration.
2	Follower (Speed)	Drive operates as a speed follower in a master-follower configuration.
3	Follower (Torque)	Drive operates as a torque follower in a master-follower configuration.

P2.18.3 Master Follower Mode 2 No. 5750

Set the master-follower mode 2. This mode is used when **No. 5715 Master Follower Mode Input** is activated (true). Choices are similar as parameter **No. 5536 Master Follower Mode 1**.

P2.18.4 Number of Drives No. 5537

Set number of drives in Master Follower configuration.

P2.18.5 Drive Number No. 5751

Set the drive number in the Master Follower configuration.

P2.18.6 Follower Start Mode No. 5753

Set the start mode when the drive is operating as follower.

No.	Name	Description
0	Own Start Command	Follower starts as per own start command from the active control place.
1	Master Start Command	Follower takes the start command from master.

P2.18.7 Follower Stop Mode No. 5754

Set the stop mode when the drive is operating as follower.

No.	Name	Description
0	As Master	Follower drive will stop with same stop behavior as master drive, when run state disappears on the master drive.
1	Ramp Stop	Follower drive will execute a ramp stop, when run state disappears on the master drive.
2	Coast Stop	Follower drive will execute a coast stop, when run state disappears on the master drive.

P2.18.8 Follower Speed Reference Source No. 5755

Select the speed reference source when the drive is operating as follower (Speed).

No.	Name	Description
0	Own Reference	Follower takes reference from its own active control place.
1	Master Speed Reference (Before Ramp)	Follower uses master's speed reference before ramp as reference. Reference ramps according to follower's own ramp times.
2	Master Speed Reference (After Ramp)	Follower uses master's speed reference after ramp as reference. Follower's own speed ramp times have no effect.
3	Master Motor Frequency	Follower uses master's motor frequency as reference. Follower's own speed ramp times have no effect.
4	Master Feedback Speed	Follower uses master's feedback speed as reference. Follower's own speed ramp times have no effect.

P2.18.9 Follower Torque Reference Source No. 5756

Select the torque reference source when the drive is operating as follower (Torque).

No.	Name	Description
0	Own Reference	Follower takes reference from its own active control place.
1	Master Torque Reference (After Ramp)	Follower uses master's torque reference after ramp as reference. Follower's own torque reference ramp parameters have no effect.

P2.18.10 Master Follower Watchdog Response No. 5542

Select the drive response for a missing watchdog event in Master Follower communication.

P2.18.11 Master Follower Watchdog Delay No. 5757

Set a delay for activating the Master Follower watchdog event.

P2.18.12 Master Follower Watchdog Start Delay No. 5758

Set a start-up delay for activating the Master Follower watchdog event. The counter begins when the drive wakes up.

7.3.19 Logic Settings

This group contains logic feature related settings. For more information, refer to the *MyDrive® Insight Logic Feature Application Guide*.

P2.19.1 Logic User Parameter 1 No. 380

User parameter providing user configurability for Logic. The value is retained across power cycles.

P2.19.2 Logic User Parameter 2 No. 381

User parameter providing user configurability for Logic. The value is retained across power cycles.

P2.19.3 Logic User Parameter 3 No. 382

User parameter providing user configurability for Logic. The value is retained across power cycles.

P2.19.4 Logic User Parameter 4 No. 383

User parameter providing user configurability for Logic. The value is retained across power cycles.

P2.19.5 Logic User Parameter 5 No. 384

User parameter providing user configurability for Logic. The value is retained across power cycles.

P2.19.6 Logic User Parameter 6 No. 385

User parameter providing user configurability for Logic. The value is retained across power cycles.

P2.19.7 Logic User Parameter 7 No. 386

User parameter providing user configurability for Logic. The value is retained across power cycles.

P2.19.8 Logic User Parameter 8 No. 387

User parameter providing user configurability for Logic. The value is retained across power cycles.

P2.19.9 Logic Process Input 1 No. 360

User parameter providing input to Logic from Fieldbus. The value is not retained across power cycles.

P2.19.10 Logic Process Input 2 No. 361

User parameter providing input to Logic from Fieldbus. The value is not retained across power cycles.

P2.19.11 Logic Process Input 3 No. 362

User parameter providing input to Logic from Fieldbus. The value is not retained across power cycles.

P2.19.12 Logic Process Input 4 No. 363

User parameter providing input to Logic from Fieldbus. The value is not retained across power cycles.

P2.19.13 Logic Process Output 1 No. 370

User parameter providing output from Logic to Fieldbus. The value is not retained across power cycles.

P2.19.14 Logic Process Output 2 No. 371

User parameter providing output from Logic to Fieldbus. The value is not retained across power cycles.

P2.19.15 Logic Process Output 3 No. 372

User parameter providing output from Logic to Fieldbus. The value is not retained across power cycles.

P2.19.16 Logic Process Output 4 No. 373

User parameter providing output from Logic to Fieldbus. The value is not retained across power cycles.

7.4 Maintenance & Service

This group contains auxiliary parameters for monitoring, commissioning, and servicing the drive.

7.4.1 Software Information**P3.1.1 Application Version No. 151**

Shows the version of the application software.

7.4.1.1 Manifest

This is the manifest screen showing detailed software information in the control panel. With MyDrive® Insight, the same information is available in the “Device Info” screen. Check the available information via the control panel or MyDrive® Insight.

7.4.2 Events

When encountering issues, the drive may issue events of the Info, Warning or Fault response type. This group contains information and parameters for monitoring and simulating these events.

7.4.2.1 Active Events

This is an active events screen shown only in the control panel. With MyDrive® Insight, the same information is available in the “Events” screen. Check the available information via the control panel or MyDrive® Insight.

7.4.2.2 Event History

This is the event history screen shown only in the control panel. With MyDrive® Insight, the same information is available in the “Events” screen. Check the available information via the control panel or MyDrive® Insight.

7.4.2.3 Event Simulation

The event simulation feature can be used to trigger any drive event without meeting the event criteria. This can be used to safely preview, how the drive behaves during specific events. For instance, some events may trigger other functions, such as indications through digital outputs. This feature is useful for checking the setup, configuration, and validity of such functions during specific events.

NOTICE

This feature is for commissioning and testing purposes. It is not meant for functional use.

WARNING

This feature can stop the drive and possibly trigger external events. Do not use without proper knowledge of the system.

How to use:

1. Refer to the Events Summary Table to get the event number and details for the specific event that is of interest.
2. Set the event number with parameter **No. 1402**.
3. Activate the simulation by setting parameter **No. 1401** to the desired simulation response.
4. When wanting to end the simulation set parameter **No. 1401** back to *Disabled*.
5. If required, give a Fault Reset command to acknowledge a simulated event.
6. If required, reboot the drive to acknowledge “Trip Locked” events.

P3.2.3.1 Event Simulation No. 1401

Simulates the selected event with the selected response. Simulation begins when changing value from Disabled. To reset a simulated event, this parameter needs to be set back to Disabled first.

No.	Name	Description
0	Disabled	Event simulator is inactive
1	Lowest Response	The event selected with parameter No. 1402 is activated with its lowest event response. Note that if the event can be configured with a response parameter, the response parameter’s setting will apply to the simulation.
10	Highest Response	The event selected with parameter No. 1402 is activated with its highest event response. Note that if the event can be configured with a response parameter, the response parameter’s setting will apply to the simulation.

P3.2.3.2 Event Sim. Number No. 1402

Select an event to be simulated by its number. Refer to the Troubleshooting section to check the number of each event.

7.4.2.4 Event Auto Reset

P3.2.4.1 Auto Reset No. 1405

Enables the automatic resetting of events. If enabled the drive tries to automatically reset the fault itself. The amount of automatic retries and the retrying window are defined with parameters **No. 1406** and **No. 1407**. For the reset to be successful the fault's triggering conditions need to have been subsided. Note that only specific faults listed in the following table have the auto-reset capability.

No.	Name	Description
0	Disabled	The drive does not try to automatically reset any faults.
1	Enabled	The drive tries to automatically reset all faults that have the retry capability.

The following faults can be auto reset:

Name	Number	Name	Number	Name	Number	Name	Number
Internal Communication Fault	4601	Grid Voltage High	4164	STO Fault Ch. A	4629	28V Supply Low	4643
Bad Speed Feedback	4418	Grid Voltage Low	4165	STO Fault Ch. B	4630	3.3V Supply Low	4642
Blocked Rotor	4382	Grid Voltage Spikes	4162	Synchronization Fault	4861	Unexpected Time Adjust	4860
Configuration Error	4350	Grid Imbalance	4163	Power Option Temp. High 1	4200	AHF High Temp. Derate	5400
Current Limit Setting Fault	4380	Missing Grid Phase	4160	Power Option Temp. Imbal. 1	4204	AHF High Temp. Stop	5401
Smart Derating Fault	4377	Missing Motor Phase	4176	Inverter Temp. High 1	4104	Control Panel Connection Lost	5141
Drive to Drive Connection Lost	4638	Motor Disconnected	4175	Brake Chopper Temp. High 1	4108	Cooling Monitor	5240
DC-link Overcurrent	4373	Motor Sync Loss	4182	Rectifier Temp. High 1	4114	Event Simulation	5260
DC-link Imbalance	4148	Motor Thermal Overload	4177	Power Unit Temp. High 1	4118	External Event 1	5123
DC-link Resonance	4374	Internal Communication Fault	4607	Control Board Temp. High 1	4122	External Event 2	5124
Feedback Option Fault	4417	Option Communication Fault	4602	Power Option Temp. High 2	4201	Invalid Control Config.	5301
Function Disabled	4647	Motor Speed High	4178	Power Option Temp. Imbal. 2	4205	Invalid Motor Data	5300
DC-link Short Circuit 2	4151	Internal Fault	4859	Temperature Imbalance Brake IGBT	4131	PC Tool Connection Lost	5142
Internal Communication Fault	4606	Position Limit	4193	IGBT temperature delta	4132	Start Blocked	5302
Hardware End Limit	4195	Internal Communication Fault	4631	Rectifier Temp. High 2	4115	Lost Load Detected	5230

Name	Number	Name	Number	Name	Number	Name	Number
Thermal Overload Rectifier	4384	Power Supply Voltage	4646	Power Unit Temp. High 2	4119	Temp. Protection 1	5132
Ground Fault 0	4352	Primary Process Data Timeout	4278	Control Board Temp. High 2	4123	Temp. Protection 2	5133
Ground Fault 1	4353	PDS	4862	Power Option Temp. Low	4202	Temp. Protection 3	5134
IGBT Temp. High	4110	Internal Communication Fault	4605	Ambient Temp. Low	4102	Temp. Protection 4	5135
IGBT Temp. High	4125	High Speed Bus Sync Error	4639	Brake Chopper Temp. Low	4106	Temp. Protection 5	5136
Excessive Current Limiting	4375	High Speed Bus Error	4648	Rectifier Temp. Low	4112	Temp. Protection 6	5137
Output Current High 0	4368	Internal Fault	4858	Power Unit Temp. Low	4116	Temp. Protection 7	5147
Output Current High 1	4369	Brake Resistor Temp. High	4401	Control Board Temp. Low	4120	Temp. Protection 8	5148
Inverter Overload	4097	Rotor Angle Detection Error	4180	DC-link Voltage High 2	4144	Temp. Protection 9	5149
LCL Fan Speed Fault	4133	Secondary Process Data Timeout	4279	DC-link Voltage High 1	4145	Temp. Protection 10	5154
Grid Frequency Out of Range	4161	Shoot Through Fault In Afe	4152	DC-link Voltage Ripple	4147		
Grid Synchronization Error	4166	Current Injection Limit	4372	DC-link Voltage Low	4146		

P3.2.4.2 Auto Reset Max Attempts No. 1406

Set the maximum number of automatic resets that is allowed before a manual reset is required. 0 means the drive will auto reset infinite times. Some events cannot be auto reset due to hardware protection or for safety reasons.

P3.2.4.3 Auto Reset Time Interval No. 1407

Set the time interval from when an event happens to when it is automatically reset.

7.4.3 Operational Counters

This group shows readouts of drive's operational counters.

P3.3.1 Control Unit On Time No. 2000

Shows the total operating time for the control unit.

P3.3.2 Power Unit On Time No. 2001

Shows the total operating time for the power unit. The counter only increments if the DC link is powered.

P3.3.3 Energy Consumption No. 2002

Shows the energy consumed.

P3.3.4 Ground Faults No. 2004

Shows the total number of ground faults.

P3.3.5 Overvoltage Faults No. 2005

Shows the total number of overvoltage faults.

P3.3.6 Overcurrent Faults No. 2006

Shows the total number of overcurrent faults.

P3.3.7 Short Circuit Faults No. 2007

Shows the total number of short-circuit faults.

P3.3.8 Number of Starts No. 2008

Shows the number of starts of the motor.

P3.3.9 Active Running Hours No. 2009

Shows the total number of active running hours of the motor.

P3.3.10 Motor Operation Below 10 Hz No. 2010

Shows the number of hours of running below 10 Hz output frequency. Low speed operation with full load may decrease motor lifetime.

P3.3.11 Flash 0 Wear Counter No. 2100

Shows the erase count for most used flash 0 sector.

P3.3.12 Flash 1 Wear Counter No. 2101

Shows the erase count for most used flash 1 sector.

7.4.4 I/O Testing

The following parameters can be used to test how the available digital and analog inputs and outputs operate. For example, the min/max adjustment of an analog input terminal or signal validity of a digital output can be verified with this feature.

NOTICE

Make sure other functions are not using the same terminals before using this feature. Also make sure to reset the terminal selectors of this function before reassigning any terminals to other functions.

P3.4.1 Test Digital Input No. 3220

Select a digital input terminal to test.

No.	Name	Description
0	None (False)	No input is selected. A virtual value of FALSE is applied.
1	None (True)	No input is selected. A virtual value of TRUE is applied.
*	Fieldbus control word 1/2 digital input bits	Fieldbus CTW1 digital input bits 12-15 and CTW2 digital input bits 0-15 will be presented as options.
*	Logic Digital I/O virtual terminals	Virtual digital outputs from the Logic Feature function blocks are presented as input options.

No.	Name	Description
*	Available digital input terminals	A dynamically generated selection of available digital input terminals is presented as an option. The specific set depends on the type and number of I/O options installed in the system.

P3.4.2 Digital Input Test State **No. 3224**

Shows the state of the digital input under test.

P3.4.3 Test Digital Output **No. 3223**

Select a digital output terminal to test.

No.	Name	Description
0	None	No output is selected.
*	Fieldbus status word 2 digital output bits	Fieldbus CTW2 digital output bits 0-15 will be presented as options.
*	Logic Digital I/O virtual terminals	Virtual digital inputs to the Logic Feature function are presented as output options.
*	Available digital output and relay terminals	A dynamically generated selection of available digital output and relay terminals is presented as an option. The specific set depends on the type and number of I/O options installed in the system.

P3.4.4 Digital Output Test State **No. 3234**

Select the state of the digital output under test.

No.	Name	Description
0	Disabled	The output selected with parameter No. 3223 is disabled.
1	Enabled	The output selected with parameter No. 3223 is enabled.

P3.4.5 Test Analog Input **No. 3222**

Select an analog input terminal for testing.

No.	Name	Description
0	None	No input is selected and a value of 0% is applied to the associated function.
5	50 %	A virtual value of 50 % is applied to the associated function.
10	100 %	A virtual value of 100 % is applied to the associated function.
*	Available analog input terminals	A dynamically generated selection of available analog input terminals is presented as an option. The specific set depends on the type and number of I/O options installed in the system.

P3.4.6 Analog Input Test Value **No. 3228**

Shows the value of the analog input under test in % of the configured input range.

P3.4.7 Test Analog Output **No. 3225**

Select an analog output terminal to test.

No.	Name	Description
0	None	No input is selected and a value of 0% is applied to the associated function.
*	Available analog output terminals	A dynamically generated selection of available analog output terminals is presented as an option. The specific set depends on the type and number of I/O options installed in the system.

P3.4.8 Analog Output Test Value **No. 3226**

Set the value of the analog output under test in % of the configured output range.

P3.4.9 Temperature Test Input **No. 3221**

Select a temperature input terminal for testing.

No.	Name	Description
0	None	No input is selected and a value of 0% is applied to the associated function.
*	Available temperature measurement terminals	A dynamically generated selection of available temperature measurement terminals is presented as an option. The specific set depends on the type and number of I/O options installed in the system.

P3.4.10 Temperature Input Test Value **No. 3227**

Shows the value of the temperature input under test in degrees Celsius.

7.4.5 Backup & Restore

7.4.5.1 Backup

This is a menu screen for creating parameter backups from the control panel. With MyDrive® Insight, similar options are available via the **Backup** button within the “Parameters” screen. Check the available settings via the control panel or MyDrive® Insight.

7.4.5.2 Restore

This is a menu for restoring parameter backups from the control panel. With MyDrive® Insight, similar options are available via the **Restore** button within the “Parameters” screen. Check the available settings via the control panel or MyDrive® Insight.

7.4.6 Expert Tools

The following parameters can be used to configure cyber security settings, and to enable advanced troubleshooting features.

7.4.6.1 Cybersecurity

P3.6.1.1 Max. Login Attempts **No. 5900**

Set the maximum number of failed login attempts before lockout.

P3.6.1.2 Max. Login Cooldown Time **No. 5901**

Maximum time before login attempts are reset after failures.

P3.6.1.3 Security Event Log IP **No. 5902**

Set the IP address of the server to which a security event is logged.

P3.6.1.4 Security Event Log Port No. 5903

Server port used for security event log transmission.

P3.6.1.5 System Use Notification No. 5908

Enter the system use notification message that is displayed on the login screen.

7.4.6.2 Troubleshooting

P3.6.2.1 Force Recommissioning No. 5904

Recommission all nodes by clearing and reloading configuration.

NOTICE
This will reset node data.

P3.6.2.2 Save Diagnostic Log No. 5905

Save internal logs persistently for debugging.

NOTICE
It is important to disable this parameter when troubleshooting is complete.

P3.6.2.3 Service Access No. 5906

Temporarily enables special debug or service interfaces for maintenance. Automatically disabled after a power cycle.

NOTICE
Use with care: May expose sensitive functions and information.

7.5 Functional Safety

This menu is used for additional (so-called non-safe) configuration of the functional safety features, such as drive responses for safety events and drive behavior after acknowledging a functional safety event. The actual configuration and monitoring of the safety features is done via the “Functional Safety” tab with MyDrive® Insight.

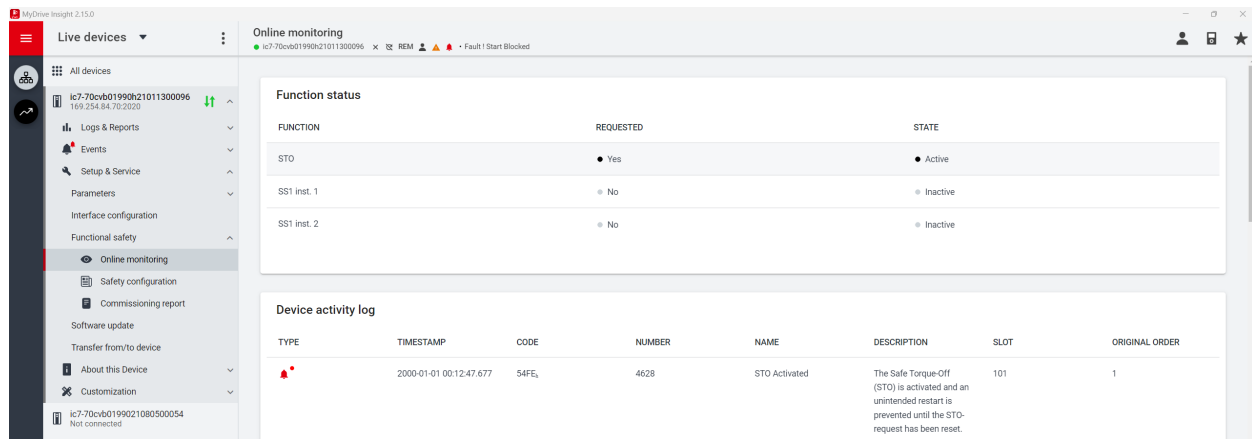

The screenshot displays the 'Functional safety' configuration and monitoring interface in MyDrive® Insight. The 'Function status' table shows the following data:

FUNCTION	REQUESTED	STATE
STO	<input checked="" type="radio"/> Yes	<input checked="" type="radio"/> Active
SS1 inst. 1	<input type="radio"/> No	<input type="radio"/> Inactive
SS1 inst. 2	<input type="radio"/> No	<input type="radio"/> Inactive

The 'Device activity log' table shows the following data:

TYPE	TIMESTAMP	CODE	NUMBER	NAME	DESCRIPTION	SLOT	ORIGINAL ORDER
	2000-01-01 00:12:47.677	SAFE_	4628	STO Activated	The Safe Torque-Off (STO) is activated and an unintended restart is prevented until the STO-request has been reset.	101	1

Figure 92: Functional safety configuration and monitoring tab in MyDrive® Insight.

In general, there are two types of configurable safety functions: Safe Torque Off (STO) and Safe Stop 1 (SS1) with two instances. The STO always stops the drive by coasting, and it is performed if the two safety input voltages are removed. The SS1 can be used to add delay before the drive performs the STO and coasts. Whether the drive stops with a configurable ramp during the delay time between the SS1 and STO events can be selected with **No. 9900** and **No. 9901**.

An I/O Failure is performed if only one of the safety input voltages is removed. An I/O Failure can be configured to perform either the STO or SS1 events. For more information related to functional safety features refer to the Functional Safety Operating Guide.

NOTICE

Select and apply the components in the safety control system appropriately to achieve the required level of operational safety.

Before integrating and using STO in an installation, carry out a thorough risk analysis on the installation to determine whether the STO functionality and safety levels are appropriate and sufficient.

7.5.1 Basic Settings

P4.1.1 Startup Acknowledge Input **No. 9922**

Select the input for acknowledging a safe startup after powering up the drive. Relevant only if Manual Startup Acknowledge is set to Nonsafe Acknowledge Required in the general parameters of safety configuration tab in MyDrive® Insight.

No.	Name	Description
0	Use Reset	Fault reset from the active control place is used to acknowledge the event.
*	Fieldbus control word 2 digital input bits	Fieldbus CTW2 digital input bits 0-15 will be presented as options.
*	Logic Digital I/O virtual terminals	Virtual digital outputs from the Logic Feature function blocks are presented as input options.
*	Available digital input terminals	A dynamically generated selection of available digital input terminals is presented as an option. The specific set depends on the type and number of I/O options installed in the system.

P4.1.2 I/O Failure Acknowledge Input **No. 9921**

Select the input for acknowledging an I/O failure. Relevant only if Restart Behaviour for Release of I/O Failure is set to Nonsafe Acknowledge Required in the general parameters of safety configuration in MyDrive® Insight.

No.	Name	Description
0	Use Reset	Fault reset from the active control place is used to acknowledge the event.
*	Fieldbus control word 2 digital input bits	Fieldbus CTW2 digital input bits 0-15 will be presented as options.
*	Logic Digital I/O virtual terminals	Virtual digital outputs from the Logic Feature function blocks are presented as input options.
*	Available digital input terminals	A dynamically generated selection of available digital input terminals is presented as an option. The specific set depends on the type and number of I/O options installed in the system.

7.5.2 STO

P4.2.1 Safe Torque Off Response **No. 9910**

Select the response of the drive to the activation of Safe Torque Off.

No.	Name	Description
14	Warning	The drive will issue a warning event and stop modulation immediately. A fault reset is not needed for drive to restart after acknowledging an STO event.
15	Fault	The drive will issue a fault event and stop modulation immediately. A fault reset is needed for drive restart after acknowledging an STO event.

P4.2.2 Safe Torque Off Output **No. 9911**

Select an output terminal for signaling the activation of Safe Torque Off.

No.	Name	Description
0	None	No output is selected.
*	Fieldbus status word 2 digital output bits	Fieldbus CTW2 digital output bits 0-15 will be presented as options.
*	Logic Digital I/O virtual terminals	Virtual digital inputs to the Logic Feature function blocks are presented as output options.
*	Available digital output and relay terminals	A dynamically generated selection of available digital output and relay terminals is presented as an option. The specific set depends on the type and number of I/O options installed in the system.

P4.2.3 Safe Torque Off Acknowledge Input **No. 9920**

Select the input for acknowledging Safe Torque Off. Relevant only if Restart behaviour for release of STO is set to Nonsafe Acknowledge Required in the STO parameters of safety configuration tab in MyDrive® Insight.

No.	Name	Description
0	Use Reset	Fault reset from the active control place is used to acknowledge the event.
*	Fieldbus control word 2 digital input bits	Fieldbus CTW2 digital input bits 0-15 will be presented as options.
*	Logic Digital I/O virtual terminals	Virtual digital outputs from the Logic Feature function blocks are presented as input options.
*	Available digital input terminals	A dynamically generated selection of available digital input terminals is presented as an option. The specific set depends on the type and number of I/O options installed in the system.

7.5.3 SS1

P4.3.1 Safe Stop 1 Response **No. 9901**

Select the response for Safe Stop 1.

No.	Name	Description
0	No Response	The drive detects that Safe Stop is activated but relies on external action to stop during the SS1 maximum time (configured from SS1 tab in MyDrive® Insight). After the maximum time the STO will be performed regardless of motor state.
1	Stop with Safe Ramp	The drive detects that Safe Stop is activated and ramps down using the ramp configured with No. 9900. The STO will be performed after the set SS1 maximum time (configured from SS1 tab in MyDrive® Insight) regardless of motor state.

P4.3.2 Safe Deceleration Ramp **No. 9900**

Set deceleration time from Nominal Speed in Hz to 0 Hz after a Safe Stop event.

7.6 Device Settings

7.6.1 Time & Units

This group houses basic customization settings such as date, time and unit selections.

P5.1.1 Date and Time **No. 2800**

Set the actual time and date. The format is YYYY-MM-DD and HH:MM:SS.

P5.1.2 Unit Selection **No. 2801**

Select the unit system used. Setting the value for this parameter will automatically set the unit parameters **2827**, **2815**, **2814**, **2829** and **2828** to their respective SI or USCS values. Afterwards these parameters can be changed individually.

No.	Name	Description
0	SI (metric units)	
1	USCS (United States customary units)	

P5.1.3 Speed Unit **No. 2813**

Select the speed unit.

No.	Name	Description
0	Hz	Herz
1	RPM	Revolution per minute

P5.1.4 Torque Unit No. 2827

Select torque unit.

No.	Name	Description
0	Nm	Newton-meter
1	lbf · ft	pound-force foot

P5.1.5 Power Unit No. 2815

Select unit for power.

No.	Name	Description
0	kW	Kilowatt
1	hp	Horsepower

P5.1.6 Temperature Unit No. 2814

Select unit for temperature.

No.	Name	Description
0	°C	Degrees Celsius
1	°F	Degrees Fahrenheit

P5.1.7 Length Unit No. 2829

Select length unit.

No.	Name	Description
0	m	Meter
1	ft	Foot

P5.1.8 Inertia Unit No. 2828

Select inertia unit.

No.	Name	Description
0	kg · m ²	Kilogram square-meter
1	lb · ft ²	Pound square-foot

P5.1.9 Time Mode No. 6232

Select the mode for defining the system time.

No.	Name	Description
0	Manual	System time is set with parameter No. 2800 .

No.	Name	Description
1	Auto (NTP)	System time is set by a Network Time Protocol server if available.

P5.1.10 NTP Server 1 No. 6233

Set the IPv4 address of the requested NTP server 1.

P5.1.11 NTP Server 2 No. 6234

Set the IPv4 address of the requested NTP server 2.

7.6.2 Control Panel

The parameters in this group allow the selecting of 1-5 signals for monitoring in the two control panel readout screens. These screens are visible in the panel's home screen, which can be accessed by pressing the **Home**-button (the house icon). Readout Screen 1 will appear first. By navigating downwards with the arrow-buttons, Readout Screen 2 will appear.

7.6.2.1 Status 1

P5.2.1.1 Readout Field 1.1 No. 300

Select the parameter for readout field (screen 1 field 1).

No.	Name	Description
0	Automatic	The value depends on the active control mode No. 3460 .
9011	Motor Electrical Speed	
9000	Motor Current	
9010	Motor Shaft Speed	
9009	Motor Torque	
1708	Relative Motor Torque	
9005	Motor Voltage	
9008	Motor Shaft Power	
674	Load Drooping Speed	
666	Estimated Inertia	
1718	Speed Reference	
6151	Final Speed Reference	
6153	Control Panel Speed Reference	
6155	Local Torque Reference	
9007	Feedback Speed	
9044	DC-link Voltage	
9041	Grid Frequency	
9040	Line-To-Line Voltage (RMS)	
9048	L1-L2 Line Voltage (RMS)	
9049	L2-L3 Line Voltage (RMS)	
9050	L3-L1 Line Voltage (RMS)	
9047	Grid Voltage Imbalance	

P5.2.1.2 Readout Field 1.2 No. 301

Select the parameter for readout field (screen 1 field 2).

No.	Name	Description
0	None	
9011	Motor Electrical Speed	
9000	Motor Current	
9010	Motor Shaft Speed	
9009	Motor Torque	
1708	Relative Motor Torque	
9005	Motor Voltage	
9008	Motor Shaft Power	
674	Load Drooping Speed	
666	Estimated Inertia	
1718	Speed Reference	
6151	Final Speed Reference	
6153	Control Panel Speed Reference	
6155	Local Torque Reference	
9007	Feedback Speed	
9044	DC-link Voltage	
9041	Grid Frequency	
9040	Line-To-Line Voltage (RMS)	
9048	L1-L2 Line Voltage (RMS)	
9049	L2-L3 Line Voltage (RMS)	
9050	L3-L1 Line Voltage (RMS)	
9047	Grid Voltage Imbalance	

P5.2.1.3 Readout Field 1.3 No. 302

Select the parameter for readout field (screen 1 field 3).
Same selection as Field 1.2 (**No. 301**).

P5.2.1.4 Readout Field 1.4 No. 303

Select the parameter for readout field (screen 1 field 4).
Same selection as Field 1.2 (**No. 301**).

P5.2.1.5 Readout Field 1.5 No. 304

Select the parameter for readout field (screen 1 field 5).
Same selection as Field 1.2 (**No. 301**).

7.6.2.2 Status 2**P5.2.2.1 Readout Field 2.1 No. 310**

Select the parameter for readout field (screen 2 field 1).
Same selection as Field 1.2 (**No. 301**).

P5.2.2.2 Readout Field 2.2 No. 311

Select the parameter for readout field (screen 2 field 2).
Same selection as Field 1.2 (**No. 301**).

P5.2.2.3 Readout Field 2.3 No. 312

Select the parameter for readout field (screen 2 field 3).
Same selection as Field 1.2 (**No. 301**).

P5.2.2.4 Readout Field 2.4 No. 313

Select the parameter for readout field (screen 2 field 4).
Same selection as Field 1.2 (**No. 301**).

P5.2.2.5 Readout Field 2.5 No. 314

Select the parameter for readout field (screen 2 field 5).
Same selection as Field 1.2 (**No. 301**).

7.6.3 Custom Status Word

The custom status word can be used to define a status word for the drive, which includes freely selectable bits from a set of other drive status words. The following status words can be used to for the Custom Status Word:

- Fieldbus Status Word, Motor Control Status Word, Motor Regulator Status Word, Application Specific Status Word 1, Application Status Word 2.

The custom status word can be monitored with parameter **No. 2410**.

The content for this word can be selected with individual parameters associated with each bit of the word. The content can be picked from other drive words. The value is given in the format of WBB, where W stands for the selection of the word and BB stands for the bit number within that word. Refer to the following table for the available content and their associated values.

FB Status Word (iC Generic Profile)*	Motor Control Status
100 Ready to be Switched On	200 Ready
101 Ready to start	201 Run
102 Running	202 Reverse
103 Fault Active	203 Fault
104	204 Reference Chain Released
105 Quick Stop	205 At Reference
106	206 Zero Speed
107 Warning Active	207 Protection Mode Active
108	208
109 Fieldbus Control Active	209
110	210
111 Run Enabled	211
112	212
113	213

Application Guide

114		214	
115	Watchdog Feedback	215	
Motor Regulator Status		Application Status Word 1	
300	Current Limit (Motoring)	400	Ready
301	Current Limit (Regenerating)	401	Run
302	Torque Limit (Motoring)	402	Info (Static)
303	Torque Limit (Regenerating)	403	Warning (Static)
304	Over Voltage Control Active	404	Fault (Static)
305	Under Voltage Control Active	405	PC Control Active
306	Power Limit (Motoring)	406	Panel Control Active
307	Power Limit (Regenerating)	407	I/O Control Active
308	Speed Limit Control Active	408	Fieldbus Control Active
309	AC-Brake Control Active	409	Advanced Control Active
310		410	Reserved
311		411	Run Enabled
312		412	Start Command Active
313		413	Quick Stop Active
314		414	Force Stopped From Control Panel
315		415	
Application Status Word 2			
500	Info Active (toggles)		
501	Warning Active (toggles)		
502	Fault Active (toggles)		
503	Speed Feedback In Use		
504	<i>Reserved</i>		
505	Reverse (Speed Reference)		
506	Reverse (Motor Speed)		
507	Mechanical Brake Open Feedback		
508	Mechanical Brake Close Feedback		
509	Mechanical Brake Close Command		
510	Interlocks active		
511	Speed Control Active		
512	Torque Control Active		
513	Power Control Active		
514			
515			

*Note: The content of this word changes according to the selected fieldbus profile PXXXX.

Example: To assign the Application Specific Status Word bit 3 "Warning (Static)" to be bit 1 of the Custom Status Word, input 403 to the parameter **No. 2411 Custom Status Word B0**.

P5.3.1 Custom Status Word B0 No. 2411

Select the content of the respective bit of the custom status word. The content can be picked from other drive words. The value is given in a format of WBB, where W stands for the selection of the word and BB stands for the bit number within that word. Refer to the following list for the available W-values.

P5.3.2 Custom Status Word B1 No. 2412

Select the content of the respective bit of the custom status word. The content can be picked from other drive words. The value is given in a format of WBB, where W stands for the selection of the word and BB stands for the bit number within that word. Refer to the following list for the available W-values.

P5.3.3 Custom Status Word B2 No. 2413

Select the content of the respective bit of the custom status word. The content can be picked from other drive words. The value is given in a format of WBB, where W stands for the selection of the word and BB stands for the bit number within that word. Refer to the following list for the available W-values.

P5.3.4 Custom Status Word B3 No. 2414

Select the content of the respective bit of the custom status word. The content can be picked from other drive words. The value is given in a format of WBB, where W stands for the selection of the word and BB stands for the bit number within that word. Refer to the following list for the available W-values.

P5.3.5 Custom Status Word B4 No. 2415

Select the content of the respective bit of the custom status word. The content can be picked from other drive words. The value is given in a format of WBB, where W stands for the selection of the word and BB stands for the bit number within that word. Refer to the following list for the available W-values.

P5.3.6 Custom Status Word B5 No. 2416

Select the content of the respective bit of the custom status word. The content can be picked from other drive words. The value is given in a format of WBB, where W stands for the selection of the word and BB stands for the bit number within that word. Refer to the following list for the available W-values.

P5.3.7 Custom Status Word B6 No. 2417

Select the content of the respective bit of the custom status word. The content can be picked from other drive words. The value is given in a format of WBB, where W stands for the selection of the word and BB stands for the bit number within that word. Refer to the following list for the available W-values.

P5.3.8 Custom Status Word B7 No. 2418

Select the content of the respective bit of the custom status word. The content can be picked from other drive words. The value is given in a format of WBB, where W stands for the selection of the word

and BB stands for the bit number within that word. Refer to the following list for the available W-values.

P5.3.9 Custom Status Word B8 No. 2419

Select the content of the respective bit of the custom status word. The content can be picked from other drive words. The value is given in a format of WBB, where W stands for the selection of the word and BB stands for the bit number within that word. Refer to the following list for the available W-values.

P5.3.10 Custom Status Word B9 No. 2420

Select the content of the respective bit of the custom status word. The content can be picked from other drive words. The value is given in a format of WBB, where W stands for the selection of the word and BB stands for the bit number within that word. Refer to the following list for the available W-values.

P5.3.11 Custom Status Word B10 No. 2421

Select the content of the respective bit of the custom status word. The content can be picked from other drive words. The value is given in a format of WBB, where W stands for the selection of the word and BB stands for the bit number within that word. Refer to the following list for the available W-values.

P5.3.12 Custom Status Word B11 No. 2422

Select the content of the respective bit of the custom status word. The content can be picked from other drive words. The value is given in a format of WBB, where W stands for the selection of the word and BB stands for the bit number within that word. Refer to the following list for the available W-values.

P5.3.13 Custom Status Word B12 No. 2423

Select the content of the respective bit of the custom status word. The content can be picked from other drive words. The value is given in a format of WBB, where W stands for the selection of the word and BB stands for the bit number within that word. Refer to the following list for the available W-values.

P5.3.14 Custom Status Word B13 No. 2424

Select the content of the respective bit of the custom status word. The content can be picked from other drive words. The value is given in a format of WBB, where W stands for the selection of the word and BB stands for the bit number within that word. Refer to the following list for the available W-values.

P5.3.15 Custom Status Word B14 No. 2425

Select the content of the respective bit of the custom status word. The content can be picked from other drive words. The value is given in a format of WBB, where W stands for the selection of the word and BB stands for the bit number within that word. Refer to the following list for the available W-values.

P5.3.16 Custom Status Word B15 No. 2426

Select the content of the respective bit of the custom status word. The content can be picked from other drive words. The value is given in a format of WBB, where W stands for the selection of the word

and BB stands for the bit number within that word. Refer to the following list for the available W-values.

7.7 Option Board Settings

This group contains readouts and parameters for setting up input and output options such as digital and analog I/O, feedback signals, or thermal measurements. The associated parameters appear in this menu based on the options connected to the drive. Note that the follow is not a definitive set of all iC7 compatible options, but just a collection of the most common and relevant options for the Propulsion & Machinery application.

7.7.1 I/O And Relay

This group and its subgroups appear only if an I/O And Relay OC7C1 option is included in the drive. This menu appears as many times as there are these options in the system. Each menu and its parameters have the suffix of their option slot.

7.7.1.1 I/O And Relay Status

P9.3.1 Digital Input Bit Word **No. 1614**

Shows the bitwise status of each digital input of this board.

Bit No.	Name	Description
0	Digital Input T13	TRUE = Over 15 V DC is applied between X13 T13 and Digital Input GND. FALSE = Less than 5 V DC is applied between X13 T13 and Digital Input GND.
1	Digital Input T14	TRUE = Over 15 V DC is applied between X13 T14 and Digital Input GND. FALSE = Less than 5 V DC is applied between X13 T14 and Digital Input GND.
2	Digital Input T15	TRUE = Over 15 V DC is applied between X13 T15 and Digital Input GND. FALSE = Less than 5 V DC is applied between X13 T15 and Digital Input GND.
3	Digital Input T16	TRUE = Over 15 V DC is applied between X13 T16 and Digital Input GND. FALSE = Less than 5 V DC is applied between X13 T16 and Digital Input GND.
4	Digital Input T17	TRUE = Over 15 V DC is applied between X13 T17 and Digital Input GND. FALSE = Less than 5 V DC is applied between X13 T17 and Digital Input GND.
5	Digital Input T18	TRUE = Over 15 V DC is applied between X13 T18 and Digital Input GND. FALSE = Less than 5 V DC is applied between X13 T18 and Digital Input GND.
6-11	Reserved	
12	Thermistor T71	TRUE = More than 4 k Ω is connected between X51 T71 and T72. FALSE = Less than 4 k Ω is connected between X51 T71 and T72.
13-15	Reserved	

P9.3.2 Digital Output Bit Word **No. 1615**

Shows the bitwise status of each digital output of this board.

Bit No.	Name	Description
0-1	Reserved	
2	Digital Output T21	TRUE = Connection between X13 T21 and I/O GND is active. FALSE = Connection between X13 T21 and I/O GND is inactive.
3	Digital Output T22	TRUE = Connection between X13 T22 and I/O GND is active.

Bit No.	Name	Description
		FALSE = Connection between X13 T22 and I/O GND is inactive.
4-11	Reserved	
12	Relay T02	TRUE = Connection between X101 T01 (COM) and T02 (NO) is active. FALSE = Connection between X101 T01 (COM) and T03 (NC) is active.
13	Relay T05	TRUE = Connection between X102 T04 (COM) and T05 (NO) is active. FALSE = Connection between X102 T04 (COM) and T06 (NC) is active.
14	Relay T08	TRUE = Connection between X103 T04 (COM) and T08 (NO) is active. FALSE = Connection between X103 T04 (COM) and T08 (NO) is inactive.
15	Reserved	

P9.3.3 T31 Analog Output Value No. 1613

Shows the actual value of the terminal.

P9.3.4 T33 Analog Input Value No. 1611

Shows the actual value of the terminal.

P9.3.5 T34 Analog Input Value No. 1612

Shows the actual value of the terminal.

7.7.1.2 Digital Inputs/Outputs

7.7.1.2.1 Input T13

P9.4.1.1 T13 Terminal Mode No. 2015

Select the mode for the terminal.

No.	Name	Description
0	Inactive	
3	Digital Input	

P9.4.1.2 T13 Signal Inversion No. 2291

Select whether the signal of the terminal is inverted.

No.	Name	Description
0	Non-Inverted	
1	Digital Inverted	

P9.4.1.3 T13 Standard Debounce Filtering Time No. 2024

Set the standard debounce filtering time for the terminal.

7.7.1.2.2 Input T14

P9.4.2.1 T14 Terminal Mode No. 2016

Select the mode for the terminal.

No.	Name	Description
0	Inactive	

No.	Name	Description
3	Digital Input	

P9.4.2.2 T14 Signal Inversion No. 2292

Select whether the signal of the terminal is inverted.

No.	Name	Description
0	Non-Inverted	
1	Digital Inverted	

P9.4.2.3 T14 Standard Debounce Filtering Time No. 2029

Set the standard debounce filtering time for the terminal.

7.7.1.2.3 Input T15

P9.4.3.1 T15 Terminal Mode No. 2022

Select the mode for the terminal.

No.	Name	Description
0	Inactive	
3	Digital Input	

P9.4.3.2 T15 Signal Inversion No. 2295

Select whether the signal of the terminal is inverted.

No.	Name	Description
0	Non-Inverted	
1	Digital Inverted	

P9.4.3.3 T15 Standard Debounce Filtering Time No. 2297

Set the standard debounce filtering time for the terminal.

7.7.1.2.4 Input T16

P9.4.4.1 T16 Terminal Mode No. 2298

Select the mode for the terminal.

No.	Name	Description
0	Inactive	
3	Digital Input	

P9.4.4.2 T16 Signal Inversion No. 2296

Select whether the signal of the terminal is inverted.

No.	Name	Description
0	Non-Inverted	

No.	Name	Description
1	Digital Inverted	

P9.4.4.3 T16 Standard Debounce Filtering Time **No. 2260**
Set the standard debounce filtering time for the terminal.

7.7.1.2.5 Input T17

P9.4.5.1 T17 Terminal Mode **No. 2017**
Select the mode for the terminal.

No.	Name	Description
0	Inactive	
3	Digital Input	

P9.4.5.2 T17 Signal Inversion **No. 2293**
Select whether the signal of the terminal is inverted.

No.	Name	Description
0	Non-Inverted	
1	Digital Inverted	

P9.4.5.3 T17 Standard Debounce Filtering Time **No. 2034**
Set the standard debounce filtering time for the terminal.

7.7.1.2.6 Input T18

P9.4.6.1 T18 Terminal Mode **No. 2018**
Select the mode for the terminal.

No.	Name	Description
0	Inactive	
3	Digital Input	

P9.4.6.2 T18 Signal Inversion **No. 2294**
Select whether the signal of the terminal is inverted.

No.	Name	Description
0	Non-Inverted	
1	Inverted	

P9.4.6.3 T18 Standard Debounce Filtering Time **No. 2039**
Set the standard debounce filtering time for the terminal.

7.7.1.2.7 Output T21

P9.4.7.1 T21 Terminal Mode **No. 4015**
Select the mode for the terminal.

No.	Name	Description
0	Inactive	
1	Digital Output	

P9.4.7.2 T21 Digital Output Type No. 4013

Select the operating logic for the digital output.

No.	Name	Description
0	Tri state	
1	Open collector sink (NPN)	
2	Open collector source (PNP)	
3	Push pull	

7.7.1.2.8 Output T22

P9.4.8.1 T22 Terminal Mode No. 4016

Select the mode for the terminal.

No.	Name	Description
0	Inactive	
1	Digital Output	

P9.4.8.2 T22 Digital Output Type No. 4014

Select the operating logic for the digital output.

No.	Name	Description
0	Tri state	
1	Open collector sink (NPN)	
2	Open collector source (PNP)	
3	Push pull	

7.7.1.3 Analog Inputs/Outputs

7.7.1.3.1 Output T31

P9.5.1.1 T31 Terminal Mode No. 2019

Select the mode for the terminal.

No.	Name	Description
0	Inactive	
5	Analog Output	

P9.5.1.2 T31 Terminal Type No. 2284

Select the type of the terminal. If voltage is selected, the unit is V. If current is selected, the unit is mA.

No.	Name	Description
0	Off	
1	Voltage	
2	Current	

P9.5.1.3 T31 Minimum Value No. 2283

Set the voltage or current representing 0% of the signal.

P9.5.1.4 T31 Maximum Value No. 2282

Set the voltage or current representing 100% of the signal.

7.7.1.3.2 Input T33**P9.5.2.1 T33 Terminal Mode No. 2020**

Select the mode for the terminal.

No.	Name	Description
0	Inactive	
6	Analog Input	

P9.5.2.2 T33 Terminal Type No. 2273

Select the type of the terminal. If voltage is selected, the unit is V. If current is selected, the unit is mA.

No.	Name	Description
1	Voltage	
2	Current	

P9.5.2.3 T33 Minimum Value No. 2272

Set the voltage or current representing 0% of the signal.

P9.5.2.4 T33 Maximum Value No. 2271

Set the voltage or current representing 100% of the signal.

P9.5.2.5 T33 Filter Time No. 2270

Set the filter time for the terminal.

P9.5.2.6 T33 Live Zero Threshold Value No. 2274

Set the live zero threshold value for the terminal. The response to a live zero event is defined with parameter **No. 4555 Live Zero Response**.

P9.5.2.7 T33 Live Zero Timeout Value No. 2275

Set the live zero timeout value for the terminal. The response to a live zero event is defined with parameter **No. 4555 Live Zero Response**.

7.7.1.3.3 Input T34

P9.5.3.1 T34 Terminal Mode No. 2021

Select the mode for the terminal.

No.	Name	Description
0	Inactive	
6	Analog Input	

P9.5.3.2 T34 Terminal Type No. 2279

Select the type of the terminal. If voltage is selected, the unit is V. If current is selected, the unit is mA.

No.	Name	Description
1	Voltage	
2	Current	

P9.5.3.3 T34 Minimum Value No. 2278

Set the voltage or current representing 0% of the signal.

P9.5.3.4 T34 Maximum Value No. 2277

Set the voltage or current representing 100% of the signal.

P9.5.3.5 T34 Filter Time No. 2276

Set the filter time for the terminal.

P9.5.3.6 T34 Live Zero Threshold Value No. 2280

Set the live zero threshold value for the terminal. The response to a live zero event is defined with parameter **No. 4555 Live Zero Response**.

P9.5.3.7 T34 Live Zero Timeout Value No. 2281

Set the live zero timeout value for the terminal. The response to a live zero event is defined with parameter **No. 4555 Live Zero Response**.

7.7.2 Encoder/Resolver

This group and its subgroups appear only if an Encoder/Resolver OC7M0 option is included in the drive. This menu appears as many times as there are these options in the system. Each menu and its parameters have the suffix of their option slot.

7.7.2.1 Encoder/Resolver Status

P9.1.1 Channel 1 Singleturn Angle No. 4065

Shows the raw singleturn angle of encoder connected to channel 1. The value is scaled from 0 to $2^{32}-1$.

P9.1.2 Channel 1 Revolutions No. 4066

Shows the number of multiturn revolutions for channel 1.

P9.1.3 Channel 1 Zero Angle No. 4067

Shows the raw singleturn angle at latest zero pulse at channel 1. The value is scaled from 0 to $2^{32}-1$.

P9.1.4 Channel 1 Encoder Status Word**No. 4068**

Shows a status indication for encoder connected to channel 1.

Bit No.	Name	Description
0	Protection error	Encoder not plugged in, supply error, resolver signal error, miswiring or short circuit, signal errors in tracks A, B, Z or D or invalid data.
1	<i>Reserved</i>	
2	Absolute encoder FSM error	The Finite State Machine has picked up an error from the encoder protocol IP when synchronizing the absolute encoder with the control cycle.
3	Absolute encoder timeout	Absolute encoder data transfer has timed out
4-6	<i>Reserved</i>	
7	Invalid data	The data is not (yet) valid because the channel is either not active or the encoder is still initializing or calibrating.
8	Absolute encoder IP error	The IP is in an error state or the signal is invalid or missing.
9	Absolute encoder corrupter position data	Even though the absolute position transfer is completed the transferred data cannot be used, for example due to an error flag from the encoder or a BiSS-C CRC failure. This error cannot occur for dual output encoders, because the missing information is supplemented using the incremental encoder output.
10	Absolute encoder outgoing command error	A command/control instruction going out to the absolute encoder failed or could not be delivered.
11	<i>Reserved</i>	
12	Incremental encoder direction error	The incremental channel of an absolute encoder with incremental output is reporting motion in the opposite direction as the absolute encoder signal. This indicates a wiring fault, for example an inversion of the differential signal on channel A or B.
13	Incremental encoder resolution error	A revolution reported by an incremental encoder does not equal the revolution of an absolute or Z-pulse reference. This indicates that the incremental resolution (PPR) is set to an incorrect value.
14	Incremental SinCos encoder calibration error	The analog angle of a SinCos encoder is out of sync with the incremental counters. This triggers a calibration sequence, which resets the incremental position. Calibration fails if the encoder signal level is below 0.875 V.
15	Incremental encoder Z-pulse pending	The first Z-pulse is still pending after completing the first revolution.

P9.1.5 Channel 2 Singleturn Angle**No. 4006**Shows the raw singleturn angle of encoder connected to channel 2. The value is scaled from 0 to $2^{32}-1$.**P9.1.6 Channel 2 Revolutions****No. 4007**

Shows the number of multiturn revolutions for channel 2.

P9.1.7 Channel 2 Zero Angle**No. 4012**Shows the raw singleturn angle at latest zero pulse at channel 2. The value is scaled from 0 to $2^{32}-1$.**P9.1.8 Channel 2 Encoder Status Word****No. 4018**

Shows a status indication for encoder connected to channel 2.

Bit No.	Name	Description
0-6	<i>Reserved</i>	
7	Invalid data	The data is not (yet) valid because the channel is either not active or the encoder is still initializing or calibrating.
8-11	<i>Reserved</i>	
12	Incremental encoder direction error	The incremental channel of an absolute encoder with incremental output is reporting motion in the opposite direction as the absolute encoder signal. This indicates a wiring fault, for example an inversion of the differential signal on channel A or B.
13	Incremental encoder resolution error	A revolution reported by an incremental encoder does not equal the revolution of an absolute or Z-pulse reference. This indicates that the incremental resolution (PPR) is set to an incorrect value.
14	Incremental SinCos encoder calibration error	The analog angle of a SinCos encoder is out of sync with the incremental counters. This triggers a calibration sequence, which resets the incremental position. Calibration fails if the encoder signal level is below 0.875 V.
15	Incremental encoder Z-pulse pending	The first Z-pulse is still pending after completing the first revolution.

P9.1.9 Encoder Status Word **No. 4019**

Shows an overall status indication represented in the following bits.

Bit No.	Name	Description
0	No Plug Detected	Encoder is not plugged in.
1	Supply Error	Internal power supply error.
2	Resolver Error	Resolver signal error.
3	Protection Error	Shorts or incorrect wiring correction.
4	Track A Error	Signal error on track A.
5	Track B Error	Signal error on track B.
6	Track Z Error	Signal error on track Z..
7	Track D Error	Signal error on track D
8-14	<i>Reserved</i>	
15	Data Not Ready	No valid feedback data has been encountered.

7.7.2.2 Configuration

P9.4.1 Interface Configuration **No. 4000**

Select the required configuration of the interface consisting of 4 tracks A, B, Z and D. The interface offers various combinations of 1 or 2 devices.

No.	Name	Description
0	Disabled	
1	2 track incremental A,B	
3	3 track incremental A,B,Z	
5	2 track incremental A,B + 2 track incremental Z,D	
7	Resolver A,B	
8	Resolver A,B + mirror out Z,D	

Application Guide

No.	Name	Description
9	Resolver A,B + 2 track incremental Z,D	
10	SinCos A,B	
12	SinCos A,B + 2 track incremental Z,D	
17	SSI Z,D	
18	SSI Z,D + Resolver A,B	
19	SSI Z,D + 2 track incremental A,B	
35	SSI Z,D + SinCos A,B	
33	SSI with 2 track incremental Z,D,A,B	
34	SSI with SinCos Z,D,A,B	
22	EnDat Z,D	
38	EnDat Z,D + Resolver A,B	
23	EnDat Z,D + 2 track incremental A,B	
24	EnDat Z,D + SinCos A,B	
21	EnDat with 2 track incremental Z,D,A,B	
20	EnDat with SinCos Z,D,A,B	
25	HIPERFACE A,B,D	
26	HIPERFACE DSL D	
27	HIPERFACE DSL D + 2 track incremental A,B	
39	HIPERFACE DSL D + SinCos A,B	
29	BiSS Z,D	
36	BiSS Z,D + Resolver A,B	
30	BiSS Z,D + 2 track incremental A,B	
37	BiSS Z,D + SinCos A,B	
31	BiSS with 2 track incremental Z,D,A,B	
32	BiSS with SinCos Z,D,A,B	

P9.4.2 Encoder Supply Voltage **No. 4002**

Set the supply voltage level according to the specifications of the connected encoder.

P9.4.3 Supply Sense **No. 4035**

Enable power supply cable drop compensation.

No.	Name	Description
0	Disabled	
1	Enabled	

P9.4.4 Invert Direction Channel 1 **No. 4092**

Select if signal on channel 1 is inverted. For dual output channel encoders this parameter affects the entire encoder information (absolute and incremental part).

No.	Name	Description
0	Disabled	

No.	Name	Description
1	Enabled	

P9.4.5 Invert Direction Channel 2 **No. 4093**

Select if signal on channel 2 is inverted. For dual channel encoders, this parameter only affects the incremental part, to be used if the A and B signal inputs are switched.

No.	Name	Description
0	Disabled	
1	Enabled	

7.7.2.3 Incremental Settings

P9.5.1 Resolution Channel 1 **No. 4008**

Set the resolution of the incremental encoder connected to channel 1.

P9.5.2 Resolution Channel 2 **No. 4009**

Set the resolution of the incremental encoder connected to channel 2.

7.7.2.4 Absolute Settings

P9.6.1 Singleturn Resolution **No. 4010**

Set the number of bits used for 1 revolution.

P9.6.2 Multiturn Resolution **No. 4011**

Set the number of bits used for counting the revolutions.

P9.6.3 EnDat Clock Rate **No. 4036**

Select the clock rate used for EnDat.

No.	Name	Description
0	8.33 MHz	
6	4.16 MHz	
12	2.08 MHz	
13	1 MHz	
14	0.2 MHz	
15	0.1 MHz	

P9.6.4 SSI Data Format **No. 4034**

Select the SSI data coding according to the specifications of the connected SSI encoder.

No.	Name	Description
0	Binary	
1	Gray	

P9.6.5 BiSS/SSI Clock Rate **No. 4037**

Select the clock rate used for SSI or BiSS.

No.	Name	Description
4	9600 bits/s	
5	19200 bits/s	
6	38400 bits/s	

P9.6.6 HIPERFACE Baud Rate **No. 4094**

Select the baud rate for the HIPERFACE encoder.

No.	Name	Description
2	8.33 MHz	
3	6.25 MHz	
4	5.00 MHz	
5	4.16 MHz	
6	3.57 MHz	
7	3.13 MHz	
8	2.78 MHz	
9	2.50 MHz	
10	2.27 MHz	
11	2.08 MHz	
12	1.92 MHz	
13	1.79 MHz	
14	1.67 MHz	
15	1.56 MHz	
17	1.25 MHz	
18	833 kHz	
19	625 kHz	
20	500 kHz	
21	417 kHz	
22	357 kHz	
23	313 kHz	
24	278 kHz	
25	250 kHz	
26	227 kHz	
27	208 kHz	
28	192 kHz	
29	179 kHz	
30	167 kHz	
31	156 kHz	

P9.6.7 HIPERFACE Parity **No. 4095**

Select the HIPERFACE parity.

No.	Name	Description
0	None	
2	Even	
3	Odd	

7.7.2.5 Resolver Settings

P9.7.1 Excitation Voltage **No. 4005**

Set the excitation voltage according to the specifications of the connected resolver (RMS).

P9.7.2 Excitation Frequency **No. 4004**

Set the excitation frequency according to the specifications of the connected resolver.

P9.7.3 Number of Pole Pairs **No. 4003**

Set the number of pole pairs of the connected resolver.

P9.7.4 Transformation Ratio **No. 4096**

Set the transformation ratio according to the specification of the connected resolver.

7.7.3 Temperature Measurement

This group and its subgroups appear only if a Temperature Measurement OC7T0 option is included in the drive. This menu appears as many times as there are these options in the system. Each menu and its parameters have the suffix of their option slot.

7.7.3.1 Temperature Measurement Status

P9.3.2 T4 Temperature Value **No. 4040**

Shows the measured temperature of the terminal.

P9.3.3 T8 Temperature Value **No. 4041**

Shows the measured temperature of the terminal.

P9.3.4 T12 Temperature Value **No. 4042**

Shows the measured temperature of the terminal.

P9.3.5 T16 Temperature Value **No. 4043**

Shows the measured temperature of the terminal.

P9.3.6 T20 Temperature Value **No. 4044**

Shows the measured temperature of the terminal.

7.7.3.2 Temperature inputs

7.7.3.2.1 Input T4

P9.4.1.1 T4 Terminal Mode **No. 4045**

Select the mode for the terminal.

No.	Name	Description
0	Inactive	

No.	Name	Description
7	Temperature input	

P9.4.1.2 T4 Connection Type No. 4046

Select the connection type for the sensor.

No.	Name	Description
0	No sensor	
2	2-wire	
3	3-wire	
4	4-wire	

P9.4.1.3 T4 Temperature Sensor Type No. 4047

Select which type of temperature sensor is connected to the terminal.

No.	Name	Description
0	No sensor	
1	Pt100	
2	2xPt100	
3	3xPt100	
4	Pt1000	
5	Ni1000Tk5000	
6	Ni1000Tk6180	
7	KTY84-1x0	
8	KTY84-151	
9	KTY84-152	
10	KTY81/82-1x0	
11	KTY81/82-121	
12	KTY81/82-122	
13	KTY81/82-151	
14	KTY81/82-152	
15	KTY81/82-2x0	
16	KTY81/82-221	
17	KTY81/82-222	
18	KTY81/82-251	
19	KTY81/82-252	

P9.4.1.4 T4 Offset No. 4048

Set the offset of the temperature measured.

7.7.3.2.2 Input T8

P9.4.2.1 T8 Terminal Mode No. 4049

Select the mode for the terminal.

Application Guide

No.	Name	Description
0	Inactive	
7	Temperature input	

P9.4.2.2 T8 Connection Type No. 4050

Select the connection type for the sensor.

No.	Name	Description
0	No sensor	
2	2-wire	
3	3-wire	
4	4-wire	

P9.4.2.3 T8 Temperature Sensor Type No. 4051

Select which type of temperature sensor is connected to the terminal.

No.	Name	Description
0	No sensor	
1	Pt100	
2	2xPt100	
3	3xPt100	
4	Pt1000	
5	Ni1000Tk5000	
6	Ni1000Tk6180	
7	KTY84-1x0	
8	KTY84-151	
9	KTY84-152	
10	KTY81/82-1x0	
11	KTY81/82-121	
12	KTY81/82-122	
13	KTY81/82-151	
14	KTY81/82-152	
15	KTY81/82-2x0	
16	KTY81/82-221	
17	KTY81/82-222	
18	KTY81/82-251	
19	KTY81/82-252	

P9.4.2.4 T8 Offset No. 4052

Set the offset of the temperature measured.

7.7.3.2.3 Input T12**P9.4.3.1 T12 Terminal Mode No. 4053**

Select the mode for the terminal.

No.	Name	Description
0	Inactive	
7	Temperature input	

P9.4.3.2 T12 Connection Type No. 4054

Select the connection type for the sensor.

No.	Name	Description
0	No sensor	
2	2-wire	
3	3-wire	
4	4-wire	

P9.4.3.3 T12 Temperature Sensor Type No. 4055

Select which type of temperature sensor is connected to the terminal.

No.	Name	Description
0	No sensor	
1	Pt100	
2	2xPt100	
3	3xPt100	
4	Pt1000	
5	Ni1000Tk5000	
6	Ni1000Tk6180	
7	KTY84-1x0	
8	KTY84-151	
9	KTY84-152	
10	KTY81/82-1x0	
11	KTY81/82-121	
12	KTY81/82-122	
13	KTY81/82-151	
14	KTY81/82-152	
15	KTY81/82-2x0	
16	KTY81/82-221	
17	KTY81/82-222	
18	KTY81/82-251	
19	KTY81/82-252	

P9.4.3.4 T12 Offset No. 4056

Set the offset of the temperature measured.

7.7.3.2.4 Input T16

P9.4.4.1 T16 Terminal Mode No. 2298

Select the mode for the terminal.

No.	Name	Description
0	Inactive	
7	Temperature input	

P9.4.4.2 T16 Connection Type No. 4058

Select the connection type for the sensor.

No.	Name	Description
0	No sensor	
2	2-wire	
3	3-wire	
4	4-wire	

P9.4.4.3 T16 Temperature Sensor Type No. 4059

Select which type of temperature sensor is connected to the terminal.

No.	Name	Description
0	No sensor	
1	Pt100	
2	2xPt100	
3	3xPt100	
4	Pt1000	
5	Ni1000Tk5000	
6	Ni1000Tk6180	
7	KTY84-1x0	
8	KTY84-151	
9	KTY84-152	
10	KTY81/82-1x0	
11	KTY81/82-121	
12	KTY81/82-122	
13	KTY81/82-151	
14	KTY81/82-152	
15	KTY81/82-2x0	
16	KTY81/82-221	
17	KTY81/82-222	
18	KTY81/82-251	
19	KTY81/82-252	

P9.4.4.4 T16 Offset No. 4060

Set the offset of the temperature measured.

7.7.3.2.5 Input T20

P9.4.5.1 T20 Terminal Mode No. 4017

Select the mode for the terminal.

Application Guide

No.	Name	Description
0	Inactive	
7	Temperature input	

P9.4.5.2 T20 Connection Type No. 4062

Select the connection type for the sensor.

No.	Name	Description
0	No sensor	
2	2-wire	
3	3-wire	
4	4-wire	

P9.4.5.3 T20 Temperature Sensor Type No. 4063

Select which type of temperature sensor is connected to the terminal.

No.	Name	Description
0	No sensor	
1	Pt100	
2	2xPt100	
3	3xPt100	
4	Pt1000	
5	Ni1000Tk5000	
6	Ni1000Tk6180	
7	KTY84-1x0	
8	KTY84-151	
9	KTY84-152	
10	KTY81/82-1x0	
11	KTY81/82-121	
12	KTY81/82-122	
13	KTY81/82-151	
14	KTY81/82-152	
15	KTY81/82-2x0	
16	KTY81/82-221	
17	KTY81/82-222	
18	KTY81/82-251	
19	KTY81/82-252	

P9.4.5.4 T20 Offset No. 4064

Set the offset of the temperature measured.

7.8 Connectivity

This section provides information about configuring and monitoring all types of communication interfaces as well as the communication and fieldbus protocols available. Following are the available interfaces:

- Communication interface X0 (service port).
- Communication interface X1/X2 (fieldbus ports).
- Attached communication options.

Note that the availability of different fieldbus protocols depends on the product.

7.8.1 Integrated Communication

7.8.1.1 Communication interfaces

7.8.1.1.1 Host Settings

7.8.1.1.1.1 Fully Qualified Domain Name **No. 7036**

Fully Qualified Domain Name. Consists of a host name label and at least 1 higher-level domain separated by the symbol "." with up to 240 characters in total. Each label contains up to 63 characters and starts with a lowercase letter and ends with alphanumeric lowercase character and have as interior characters only alphanumeric lowercase characters and '-'.
Note: To ensure that outgoing IP packets are routed correctly, configure the IP address of the X1/X2 interfaces to a different subnet than the IP address of the X0 interface.

7.8.1.1.2 Ethernet Interface X0

7.8.1.1.2.1 IPv4 Settings

This is a menu screen for enabling IP configuration of the X0 interface. Check the available settings via the control panel or MyDrive® Insight.

7.8.1.1.2.1.2 IPv4 Status

This is a menu screen containing information about the IP configuration of the X0 interface. Check the available information via the control panel or MyDrive® Insight.

7.8.1.1.3 Ethernet Interface X1/X2 Settings

7.8.1.1.3.1 IPv4 Settings

This is a menu screen for enabling IP configuration of the X1/2 interface. Check the available settings via the control panel or MyDrive® Insight.

Note: To ensure that outgoing IP packets are routed correctly, configure the IP address of the X1/X2 interfaces to a different subnet than the IP address of the X0 interface.

7.8.1.1.3.1.2 IPv4 Status

This is a menu screen containing information about the IP configuration of the X1/X2 interface. Check the available information via the control panel or MyDrive® Insight.

7.8.1.1.4 Ethernet port X0

7.8.1.1.4.1 X0 Settings

P10.1.1.4.1.1 Link configuration X0 **No. 7047**

Select the configuration of the Ethernet link parameters.

No.	Name	Description
0	Auto negotiation	
1	10 Mbps full duplex	
2	10 Mbps half duplex	
3	100 Mbps full duplex	
4	100 Mbps half duplex	

7.8.1.1.5 Ethernet port X1

7.8.1.1.5.1 X1 Settings

P10.1.1.5.1.1 Link Configuration X1 **No. 7048**

Select the configuration of the Ethernet link parameters.

No.	Name	Description
0	Auto negotiation	
1	10 Mbps full duplex	
2	10 Mbps half duplex	
3	100 Mbps full duplex	
4	100 Mbps half duplex	

7.8.1.1.6 Ethernet port X2

7.8.1.1.6.1 X2 Settings

P10.1.1.6.1.1 Link Configuration X2 **No. 7049**

Select the configuration of the Ethernet link parameters.

No.	Name	Description
0	Auto negotiation	
1	10 Mbps full duplex	
2	10 Mbps half duplex	
3	100 Mbps full duplex	
4	100 Mbps half duplex	

7.8.1.1.7 Port Mirroring

This is a menu screen for enabling and disabling the port-mirroring function for network troubleshooting with a network analyzer tool. Check the available configurations via the control panel or MyDrive® Insight.

7.8.1.2 Protocols

7.8.1.2.1 PROFINET®

7.8.1.2.1.1 Status

7.8.1.2.1.1.1 PROFINET® Report

This is the PROFINET® report screen showing active PROFINET® connection and configuration information. Check the available information via the control panel or MyDrive® Insight.

7.8.1.2.1.1.2 Configuration

P10.1.2.1.2.1 Name of Station **No. 7080**

Set the name of station. The PROFINET® device is identified by its name of station. Each name must be unique in the network.

7.8.1.2.1.1.3 Diagnosis

P10.1.2.1.3.1 Diagnostic Fault **No. 7081**

Enables diagnostic fault. When disabled the device will not send any PROFINET® diagnosis message with severity "Fault" when a fault is present on device.

No.	Name	Description
0	Disabled	Fault diagnosis messages are not sent.
1	Enabled	Fault diagnosis messages are sent.

P10.1.2.1.3.2 Diagnostic Warning **No. 7083**

Enables diagnostic warning. When disabled the device will not send any PROFINET® diagnosis message with severity "Maintenance required" when a warning is present on device.

No.	Name	Description
0	Disabled	Warning diagnosis messages are not sent.
1	Enabled	Warning diagnosis messages are sent.

7.8.1.2.1.2 Modbus® TCP

7.8.1.2.1.2.1 Configuration

P10.1.2.2.1.1 Persistent Storage **No. 7061**

Select if persistent storage is active for Modbus® writes.

No.	Name	Description
0	Disabled	When writing to configuration parameters via a Modbus® protocol, the latest written value is not stored to memory. If the drive is rebooted the latest written value is lost.
1	Enabled	When writing to configuration parameters a Modbus® protocol, the latest written value is stored to memory. If the drive is rebooted the latest written value is retained.

P10.1.2.2.1.2 Byte Order**No. 7062**

Select the byte order.

No.	Name	Description
0	Big Endian	<ul style="list-style-type: none"> Decreasing byte order. The value being read/written starts from the most significant byte and ends with the least significant byte of the source value.
1	Little Endian	<ul style="list-style-type: none"> Increasing byte order. The value being read/written starts from the least significant byte and ends with the most significant byte of the source value.

P10.1.2.2.1.3 Word Order**No. 7063**

Select the word order.

No.	Name	Description
0	Big Endian	<ul style="list-style-type: none"> Decreasing word order. The value being read/written starts from the most significant word and ends with the least significant word of the source value.
1	Little Endian	<ul style="list-style-type: none"> Increasing word order. The value being read/written starts from the least significant word and ends with the most significant word of the source value.

7.8.1.2.1.3 EtherNet/IP**7.8.1.2.1.3.1 Status****7.8.1.2.1.3.1.1 EtherNet/IP Report**

This is the EtherNet/IP report screen showing active EtherNet/IP connection and configuration information. Check the available information via the control panel or MyDrive® Insight.

7.8.1.2.1.4 EtherCAT®**7.8.1.2.1.4.1 Status****7.8.1.2.1.4.1.1 EtherCAT Report**

This is the EtherCAT report screen showing active EtherCAT connection and configuration information. Check the available information via the control panel or MyDrive® Insight.

7.8.1.2.1.4.2 Configuration**P10.1.2.4.2.1 Device ID****No. 7084**

The EtherCAT Explicit Device Identification is an optional feature for identifying an EtherCAT follower explicitly. If set, the value must be unique within a network configuration.

7.8.1.2.1.5 General Settings**P10.1.2.5.1 SNMP Agent****No. 5907**

Activates the local SNMP Agent.

No.	Name	Description
0	Disabled	SNMP Agent disabled.
1	Enabled	SNMP Agent enabled.

7.8.2 RS-485 Communication OC7F3

This group contains parameters for setting up an RS-485 Communication to the drive. This menu and the associated parameters appear if an RS-485 Communication OC7F3 option board is connected to the drive.

7.8.2.1 RS-485 Settings

This is a menu screen for enabling RS-485 Communication settings. The configurable parameters are port address, baud rate, data frame settings and line termination. These settings can be configured via the control panel or MyDrive® Insight. The supported choices are presented in the following table.

Name	Description
Port Address	Set the port address of the RS-485 Communication interface between 0...247.
Baud Rate	Set the baud rate for the RS-485 Communication interface. Supported baud rates are: 1200, 2400, 4800, 9600, 19200, 38400, 57600 and 115200.
Data Frame Settings	Set the desired frame settings, including number of data bits, parity, and number of stop bits. Supported settings are: 524289: 8 data bits, None parity, 1 stop bit 524290: 8 data bits, None parity, 2 stop bits 524545: 8 data bits, Odd parity, 1 stop bit 524801: 8 data bits, Even parity, 1 stop bit.
Line Termination	Enable or disable use of line termination resistor. This should be enabled only on last drive in the RS-485 bus.

7.8.2.2 Modbus® Settings

7.8.2.2.1 Persistent Storage **No. 7061**

Select if persistent storage is active for Modbus® writes.

No.	Name	Description
0	Disabled	When writing to configuration parameters via a Modbus® protocol, the latest written value is not stored to memory. If the drive is rebooted the latest written value is lost.
1	Enabled	When writing to configuration parameters a Modbus® protocol, the latest written value is stored to memory. If the drive is rebooted the latest written value is retained.

7.8.2.2.2 Byte Order **No. 7062**

Select the byte order.

No.	Name	Description
0	Big Endian	<ul style="list-style-type: none"> Decreasing byte order. The value being read/written starts from the most significant byte and ends with the least significant byte of the source value.
1	Little Endian	<ul style="list-style-type: none"> Increasing byte order. The value being read/written starts from the least significant byte and ends with the most significant byte of the source value.

7.8.2.2.3 Word Order **No. 7061**

Select the word order.

No.	Name	Description
0	Big Endian	<ul style="list-style-type: none"> Decreasing word order. The value being read/written starts from the most significant word and ends with the least significant word of the source value.
1	Little Endian	<ul style="list-style-type: none"> Increasing word order. The value being read/written starts from the least significant word and ends with the most significant word of the source value.

8 Troubleshooting

8.1 Viewing and Resetting Events

The iC7 drive series can produce three types of events. Info, Warning and Fault type events.

Info events are events mainly for notifications of situations, or to log events into the history. Info events are not highlighted through any indicator LEDs. An active info and its details can be viewed in the Active Events list and the same information is stored into the Event History. An info event is reset automatically once the triggering conditions are no longer active.

When a warning event occurs, status indicators on the control panel and control board LEDs turn yellow, and a yellow, triangular warning symbol appears in the device status panel of MyDrive® Insight. An active warning and its details can be viewed in the Active Events list and the same information is stored into the Event History. While a warning is active the drive remains operational. A warning event is reset automatically once the triggering conditions are no longer active.

When a fault event occurs, status indicators on the control panel and control board LEDs turn red, and a red, bell-shaped fault symbol appears in the device status panel of MyDrive® Insight. An active fault and its details can be viewed in the Active Events list and the same information is stored into the Event History. When a fault becomes active, the drive stops operation. Depending on the fault and settings, the drive stops modulation either immediately or after ramping the motor speed first to zero. To reset a fault event the fault triggering conditions need to be inactive, and a reset command (fault acknowledgement) needs to be given to the drive.

To access the Active Events on the control panel, press the info button on the home screen, or navigate to **“3.2.1 Active Events”** in the parameter menu. With MyDrive® Insight, establish a connection to the drive and navigate to “Events > Live”.

To access the Event History on the control panel, navigate to **“3.2.2 Event History”** in the parameter menu. With MyDrive® Insight, establish a connection to the drive and navigate to “Events > Live”.

8.2 How to read the event summary table

The following chapter contains a summarized table of all the events in a Propulsion and Machinery drive.

Events in iC7 drives have 2 different identifiers: Group numbers and Individual numbers. The group numbers for iC7 drives follow the DRIVECOM industry standard error code specification. The specification originated with the Interbus communication profile. The [Interbus V3.0 base profile](#) was released on 2018-04-19. The [inverter specific profile](#) was released on 1997-12-15. The error code specification was adopted by CAN in Automation and ODVA and is used within their respective Drive Profile. The list of standardized error codes can be found within [IEC 61800-7-201](#).

Unlike individual numbers, the group numbers are not unique since multiple errors can be related to each other. An example is different ground faults which share the Group Number 0x2330.

The rest of the table shows a display name, brief description, possible causes for the event and associated mitigation actions (if applicable).

8.3 Events Summary for Propulsion and Machinery

Group	Number	Name	Description	Possible causes	Mitigation Actions
0x2110	4379	CM Current High	An excessive common mode current has been detected in the LCL-filter.	Faulty components. Loose cable connection. Faulty cables.	Check the components, cables and connections.
0x2212	4374	DC-link Resonance	A resonance on the DC link with excessive RMS current values has been detected.	Switching frequency or its 2nd multiple is in the range of system resonance frequency.	Contact Danfoss service.
0x2221	4384	Thermal Overload Rectifier	The rectifier is thermally overloaded. Mission profile is too demanding.	Too high loading on the rectifier.	Check the load profile.
0x2222	4373	DC-link Overcurrent	An overcurrent on the main DC-link capacitors has been detected.	Faulty DC-link capacitor.	Contact Danfoss service.
0x2311	4097	Inverter Overload	Thermal overload is detected in the inverter of the drive.	Too high loading of the inverter.	Reduce the output load. Consider applying limits.
	4367	Output Current High (User Defined Limit)	The output current of the drive has exceeded the user defined limit for the overcurrent protection.	Current has exceeded limit set with No. 2368 .	Reduce the load or increase the limit.
	4368	Output Current High 0	The output current of the drive has exceeded its normal range at low speed.	Shock load or too fast acceleration with high-inertia loads can cause this fault.	Check that the motor size matches the drive, and the motor data is correct.
	4369	Output Current High 1	The output current of the drive has exceeded its normal range.		Check that the motor shaft can be turned.
	4375	Excessive Current Limiting	The output current of the drive has exceeded the current limit multiple times.	Motor and drive mismatch. Motor misconfiguration. Too high loading of the inverter. Blocked motor shaft.	Check that the motor size matches the drive, and the motor data is correct. Check that the motor shaft can be turned.
	4377	Smart Derating Fault	A Smart Derating fault is detected.	The load is too demanding for the current derating level.	Lower the switching frequency if possible.
	4380	Current Limit Setting Fault	The actual current limit setting is too high relative to the selected constant control frequency level.	Incorrect current limit or modulation settings.	Reduce the control frequency setting or reduce the current limit setting.
	5129	Overload Event	Overload is detected based on motor current, torque, or power.	Too high loading of the inverter.	Reduce the output load. Consider applying limits.
0x2330	4352	Ground Fault 0	A high-impedance	Damaged motor cable	Check the insulation of

Application Guide

Group	Number	Name	Description	Possible causes	Mitigation Actions
	4353	Ground Fault 1	ground fault is detected on the output.	or motor.	motor cable and motor.
	4354	Ground Fault 2	A low-impedance ground fault is detected on the output.		Power cycle is required. Check the insulation of motor cable and motor.
	4355	Ground Fault 21	A high or low-impedance ground fault is detected on the output.		
0x2340	4356	Inverter Short Circuit	A short circuit at the inverter output is detected.	Damaged motor cable or motor.	Power cycle is required. Check the motor and motor cable.
	4370	Output Current High 2	A critical output overcurrent is detected.	Damaged motor cable or motor.	Power cycle is required. Check for short circuits on the output.
	4649	Desat Gate Driver	The gate driver has detected desaturation condition.	Faulty component. Extremely high overcurrent.	Power cycle is required. Contact your local Danfoss service. If the fault occurs the same time as Overcurrent fault, check installations and components from AC output to load.
0x23fe	4371	Current Imbalance	A current imbalance between paralleled power units is detected.	Faulty current measurement. Impedance mismatch from parallel modules to point of common coupling. Transistor switching time compensation disabled.	Check installation connections. Contact your local Danfoss distributor.
0x23ff	4175	Motor Disconnected	The motor is disconnected. All motor phases are missing.	Faulty cable or motor. Loose connection.	Check motor, motor cables, and connections.
	4176	Missing Motor Phase	A missing motor phase is detected.		
0x3110	4162	Grid Voltage Spikes	Excessive spikes on the grid voltage have been detected.	Faulty grid supply. Loose cable connection. Faulty cables or fuses.	Check the grid supply, cables, connections, and fuses.
	4164	Grid Voltage High	Grid voltage (RMS) above the normal operating range is detected.	Faulty grid supply. Loose cable connection. Faulty cables or fuses. Wrong unit voltage class selection.	Check unit voltage class selection. Check the grid supply, cables, connections, and fuses.
0x3120	4165	Grid Voltage Low	A grid voltage (RMS) below the normal operating range is detected.	Faulty grid supply. Loose cable connection. Faulty cables or fuses.	Check unit voltage class selection. Check the grid supply, cables, connections, and

Application Guide

Group	Number	Name	Description	Possible causes	Mitigation Actions
				Wrong unit voltage class selection.	fuses.
0x3130	4160	Missing Grid Phase	A missing phase is detected on the grid side.	Faulty grid supply. Loose cable connection. Faulty cables or fuses.	Check the grid supply, cables, connections, and fuses.
	4163	Grid Imbalance	A large imbalance of the grid voltages is detected.	The grid voltage is highly distorted. High impedance mismatch between input phases.	Check for uneven loads on the grid. Check installation. Reduce drive output power.
0x3140	4161	Grid Frequency Out of Range	A grid frequency outside the normal operating range is detected.	Input line phase is missing. Rated current of supply is too low compared to the AFE unit.	Check the grid supply, cables, connections, and fuses.
	4166	Grid Synchronization Error	The drive is unable to maintain the synchronization to the grid voltage.	Grid frequency is too high or too low. Main Circuit Breaker is open.	
0x3211	4145	DC-link Voltage High 1	The voltage of the DC link is above the normal operating range and has reached a critical level.	Too fast motor braking. Grid transients.	Increase deceleration time, enable the overvoltage controller, use AC brake, or use a brake resistor while braking.
0x3212	4144	DC-link Voltage High 2	The voltage of the DC link is above the normal operating range and has reached a critical level.		
0x3221	4146	DC-link Voltage Low	The DC-link voltage is below the normal operating range.	Fault in DC-voltage supply (rectifier or front-end converter).	Check the DC-supply unit. Try to enable undervoltage protection to keep the drive running as long as possible.
0x32ff	4147	DC-link Voltage Ripple	Excessive voltage ripple is detected on the main DC-link capacitors.	Grid voltage imbalance.	Reduce the output power.
	4148	DC-link Imbalance	An imbalance across the DC-link capacitors is detected. If the fault remains after resetting the drive, service is required.	The imbalance can be caused by a component fault of the DC link.	Try resetting the drive. Inspect the drive. Service the drive. Contact Danfoss service.
0x4110	4099	Ambient Temp. High	The ambient temperature is too high.	Excessive heating or insufficient cooling of the drive's ambient temperature.	Check the temperature and cooling conditions. Lower the temperature or improve the cooling conditions.
0x4210	4107	Brake Chopper Temp.	The temperature of the	Faulty or insufficient	Check cooling and heat

Application Guide

Group	Number	Name	Description	Possible causes	Mitigation Actions
		Limit	brake chopper heat sink is at the upper limit of the normal temperature range.	cooling. Excessive power dissipation requirement.	sink conditions. Reduce the generated regenerative power.
	4108	Brake Chopper Temp. High 1	The temperature of the brake chopper heat sink has exceeded the normal temperature range.		
	4109	Brake Chopper Temp. High 2	The temperature of the brake chopper heat sink has reached a critical level.		
0x4220	4106	Brake Chopper Temp. Low	The temperature of the brake chopper heat sink is too low.	Faulty or excessive cooling. Low ambient temperature.	Check the cooling. Increase the ambient temperature. Consider the use of an external heater.
0x4280	5132	Temp. Protection 1	Temperature protection 1 is triggered. The temperature has exceeded the configured value.	The device under measurement is heating up. The probe connection is faulty.	Check the status of the monitored device. Check the probe connection.
	5133	Temp. Protection 2	Temperature protection 2 is triggered. The temperature has exceeded the configured value.		
	5134	Temp. Protection 3	Temperature protection 3 is triggered. The temperature has exceeded the configured value.		
	5135	Temp. Protection 4	Temperature protection 4 is triggered. The temperature has exceeded the configured value.		
	5136	Temp. Protection 5	Temperature protection 5 is triggered. The temperature has exceeded the configured value.		
	5137	Temp. Protection 6	Temperature protection 6 is triggered. The temperature has exceeded the configured value.		
	5147	Temp. Protection 7	Temperature protection 7 is triggered. The temperature has exceeded the configured value.		

Group	Number	Name	Description	Possible causes	Mitigation Actions
	5148	Temp. Protection 8	Temperature protection 8 is triggered. The temperature has exceeded the configured value.		
	5149	Temp. Protection 9	Temperature protection 9 is triggered. The temperature has exceeded the configured value.		
	5154	Temp. Protection 10	Temperature protection 10 is triggered. The temperature has exceeded the configured value.		
	5138	Temperature Sensor Out of Range	One of the temperature sensor readings is outside of set range.		
0x4281	5143	Thermistor Monitor 1	The input of thermistor monitor 1 has exceeded the 4 kilo ohm threshold.	The device under measurement is heating up. The thermistor connection is faulty.	Check the status of the monitored device. Check the thermistor connection.
	5144	Thermistor Monitor 2	The input of thermistor monitor 2 has exceeded the 4 kilo ohm threshold.		
	5145	Thermistor Monitor 3	The input of thermistor monitor 3 has exceeded the 4 kilo ohm threshold.		
0x42ff	4200	Power Option Temp. High 1	The temperature of a power option has exceeded the normal temperature range.	Excessive loading of the power option. Insufficient cooling of the ambient temperature around the power option.	Check the cooling conditions. Reduce the load or the ambient temperature.
	4201	Power Option Temp. High 2	The temperature of a power option has reached a critical level.		
	4202	Power Option Temp. Low	The temperature of a power option component is too low.	Excessive heating or insufficient cooling of the ambient temperature around the power option.	Check the ambient temperature. Increase the ambient temperature around the power option.
	4203	Power Option Temp. Limit	The temperature of a power option component is at the upper limit of the normal temperature.	Excessive loading of the power option. Insufficient cooling of the ambient temperature around the power option.	Check the cooling conditions. Reduce the load or the ambient temperature.
	4204	Power Option Temp. Imbal. 1	The thermal imbalance between the power option components	Faulty installation of the power option or its thermal measurement	Check the power option component for installation errors or

Application Guide

Group	Number	Name	Description	Possible causes	Mitigation Actions
			exceeds the normal operating range.	components.	defects.
	4205	Power Option Temp. Imbal. 2	An excessive thermal imbalance between power option components is detected.	Defective power option or its thermal measurement components.	Check the option's thermal measurement components for installation errors, connection issues or defects.
	4206	Power Option Temp. Imbal. Limit	The thermal imbalance between the power option components is at the upper limit of the normal operating range.		
0x4310	4103	Inverter Temp. Limit	The temperature of the inverter heat sink is at the upper limit of the normal temperature range.	High ambient temperature. Insufficient cooling. Overloading of the drive.	Check cooling and heat sink conditions. Reduce the output current or ambient temperature. The drive may derate if the temperature is not lowered.
	4104	Inverter Temp. High 1	The temperature of the inverter heat sink has exceeded the normal temperature level. Check cooling and heat sink conditions. Reduce the output current or ambient temperature.	High ambient temperature. Insufficient cooling. Overloading of the drive.	Check cooling and heat sink conditions. Reduce the output current to avoid a protected fault.
	4105	Inverter Temp. High 2	The temperature of the inverter heat sink has reached a critical level.		
	4110	IGBT Temp. High	An inverter IGBT overtemperature is detected.	High ambient temperature. Insufficient cooling. Overloading of the drive.	Reduce the ambient temperature, the output current and/or the switching frequency. Check the cooling and the condition of the heat sink.
	4113	Rectifier Temp. Limit	The temperature of the rectifier heat sink is at the upper limit of the normal temperature range.	High ambient temperature. Insufficient cooling. Overloading of the drive.	Check cooling and heat sink conditions. Reduce the output power (torque, speed) or the ambient temperature.
	4114	Rectifier Temp. High 1	The temperature of the rectifier heat sink has exceeded the normal temperature range.		
	4115	Rectifier Temp. High 2	The temperature of the rectifier heat sink has reached a critical level.		
	4117	Power Unit Temp. Limit	The internal air temperature of the drive is at the upper limit of the normal temperature range.		

Application Guide

Group	Number	Name	Description	Possible causes	Mitigation Actions
	4118	Power Unit Temp. High 1	The internal air temperature of the drive has exceeded its normal temperature range.	High ambient temperature. Insufficient cooling. Overloading of the drive.	Check cooling and heat sink conditions. Reduce the output power (torque, speed) or the ambient temperature.
	4119	Power Unit Temp. High 2	The internal air temperature of the drive has reached a critical value.		
	4125	IGBT Temp. High	An inverter IGBT temperature has reached a critical value.	High ambient temperature. Insufficient cooling. Overloading of the drive.	Reduce the drive's output current if possible to avoid a protected fault.
0x4320	4102	Ambient Temp. Low	The drive is operated at a too low ambient temperature.	Low ambient temperature. Insufficient heating or excessive cooling.	Check the ambient temperature. Increase the ambient temperature or consider an external heater to increase the temperature around the drive.
	4112	Rectifier Temp. Low	The temperature of the rectifier heat sink is too low.	Low ambient temperature. Insufficient heating or excessive cooling.	Check the ambient temperature. Increase the ambient temperature or consider an external heater to increase the temperature around the drive.
	4116	Power Unit Temp. Low	The internal air temperature of the drive is below the normal operating range.	Low ambient temperature. Insufficient heating or excessive cooling.	The drive is operated at a too low ambient temperature. Consider an external heater to avoid this warning or fault.
0x4380	5240	Cooling Monitor	The cooling signal to an external cooling unit is missing.	Faulty external cooling unit. Faulty external cooling unit signal.	Check the external cooling unit. Check the signal wiring and connections to the cooling unit.
0x43fe	4120	Control Board Temp. Low	The temperature of the control board is below the normal temperature range.	Low ambient temperature. Insufficient heating or excessive cooling.	Check the ambient temperature. Increase the ambient temperature or consider an external heater to increase the temperature at the drive.
	4121	Control Board Temp. Limit	The temperature of the control board is at the upper limit of the normal temperature range.	High ambient temperature. Insufficient cooling. Overloading of the	Check cooling conditions and load of the control board. Reduce the load on the control board or the

Application Guide

Group	Number	Name	Description	Possible causes	Mitigation Actions
	4122	Control Board Temp. High 1	The temperature of the control board has exceeded its normal temperature range.	control board.	ambient temperature. To reduce load, consider reducing switching frequency or number of active features.
	4123	Control Board Temp. High 2	The temperature of the control board has reached a critical level.		
0x43ff	4124	Break Chopper Temperature Imbalance	There is a temperature imbalance between 1 or more brake chopper IGBTs.	Defective IGBTs. Insufficient cooling. Defective driver boards.	Check the condition of IGBT modules and their connections. Check the cooling of the brake chopper. Check the driver boards
	4132	IGBT temperature delta			
	4126	IGBT Temperature Imbalance	There is a temperature imbalance between 1 or more IGBTs.	Defective IGBTs. Insufficient cooling. Defective driver boards.	
	4127	IGBT Temperature Imbalance	An excessive thermal imbalance between the IGBT modules is detected.		
	4131	Temperature Imbalance Brake IGBT	There is a temperature imbalance between 1 or more brake chopper IGBTs.		
0x4480	5400	AHF High Temp. Derate	A too high temperature is detected in the connected AHF (Advanced Harmonic Filter). Output is derated to 50%.	High ambient temperature. Insufficient cooling. Overloading of the filter. Defective filter components.	Check the ambient temperature near the AHF. Check cooling if applicable. Reduce output power. Check the condition of the AHF components and their connections.
	5401	AHF High Temp. Stop	A too high temperature is detected in the connected AHF (Advanced Harmonic Filter). Operation of the drive is stopped.		
0x5100	4641	24V Backup Mode	The drive is in 24 V backup mode. The control section (including parameter configurations) and installed options are kept operational.	No connection to the power unit.	Establish or inspect the connection to the power unit.
0x5110	4224	Analog Input Overload	Analog input overload detected.	High input voltage or current from external source. Short circuit.	Check the input voltage supply and prefer using the I/O option's own 10V source for analog inputs. Check the connections.
0x5112	4640	24V Supply Fault	The 24 V supply is outside its normal operating range for the	Faulty supply, connection, or cables in the control board +24 V	Cycle Power. Inspect the supply source.

Application Guide

Group	Number	Name	Description	Possible causes	Mitigation Actions
			control board.	external power supply.	Inspect the supply connections and cables.
	4226	Supply Overload 24V	24 V supply overload detected in an I/O option board.	Short circuit in the digital I/O +24 V control voltage terminal.	Check the connections.
0x5114	4642	3.3V Supply Low	The voltage of the power board internal 3.3 V supply is below its normal operating range.	Faulty or insufficient supply voltage for the power board.	Check the power board power supply. Check the power board.
0x5118	4643	28V Supply Low	The voltage of the power board internal 28 V supply is below its normal operating range.	Defective power board components.	Contact Danfoss service.
0x511a	4227	Supply Overload 10V	10 V supply overload detected in an I/O option.	Short circuit in the analog I/O +10 V reference voltage terminal.	Check the connections.
0x5160	4225	Digital Output Overload	Digital output overload detected.	Overcurrent in the output due to low resistive loading or short circuit.	Inspect the output connections. Consider adding pull-down resistors to reduce the current.
0x51fe	4644	Gate Driver Voltage Fault	The gate driver supply voltage is outside its normal operating range.	Faulty IGBT driver board.	Power cycle is required. Contact Danfoss service.
	4653	Gate Driver Fault	A gate driver fault is detected or a link to the gate driver is broken.	Faulty IGBT driver board or its connection	Contact Danfoss service.
0x51ff	4645	Power Board Supply Fault	A power supply fault on the power board is detected.	Faulty supply, connection, or cables in the power board +24V auxiliary power supply.	Power cycle is required. Inspect the supply source.
	4646	Power Supply Voltage	A power supply voltage is outside its normal operating range.		Inspect the supply connections and cables.
0x5210	4378	Current Sensor Fault	A defective current sensor or an error in the calibration of the current sensors is detected.	A defective current sensor. Sensor calibration error.	Service the drive. Contact Danfoss service.
0x54fd	4647	Function Disabled	The protection logic keeps the trip active until the configuration of the power unit protection levels is ready.	The Functional Safety module is misconfigured.	Check the Functional Safety Settings.
0x54fe	4628	STO Activated	The Safe Torque-Off (STO) is activated and an unintended restart is prevented until the STO-request is reset.		

Group	Number	Name	Description	Possible causes	Mitigation Actions
	4629	STO Fault Ch. A	The Safe Torque-Off (STO) is activated due to a discrepancy fault: Channel A is not activated, while channel B is activated.	An STO command was given to the drive. The STO signal or its connection is faulty. Functional Safety module is faulty or installed incorrectly.	Check the validity of the command from its source. Check the health and connection of the STO signal and the Functional Safety module.
	4630	STO Fault Ch. B	The Safe Torque-Off (STO) is activated due to a discrepancy fault: Channel B is not activated, while channel A is activated.		
0x54ff	4149	DC-link Short Circuit	An internal short circuit is detected in the DC link.	Faulty DC-link components.	Power cycle is required. Service the drive. Contact Danfoss service.
	4150	DC Capacitor Short Circuit	A short circuit in a DC-link capacitor is detected.		
	4151	DC-link Short Circuit 2	A short circuit in the DC-link capacitor is detected.		
0x5530	4790	Control Data Error	A data error is detected in the control data database EEPROM.	Control Data does not match what the current version of the control software expects.	Contact Danfoss service.
	4791	Invalid PUD	A data error is detected in the power unit database EEPROM.	Power Unit Data does not match what the current version of the control software expects.	Contact Danfoss service.
0x6100	4134	System Time Adjust	System time is adjusted.	Event for logging.	No action.
	4135	Real Time Clock Hardware Error	Hardware error is detected in real time clock.	RTC battery missing or with low charge.	Install or replace RTC battery.
	4304	License Missing	A required license is missing.	A fieldbus connection from an unlicensed protocol was attempted.	Use a licensed protocol. Acquire a license.
	4349	Authenticity Error	Files authenticity verification error occurred.	The application within the drive is either missing or unauthenticated.	Upload an authenticated application.
	4351	System Fault	A system fault is detected. See additional information for details.	Software issue.	Cycle power.

Group	Number	Name	Description	Possible causes	Mitigation Actions
	4357	Firmware Crash	A firmware crash occurred and detailed information is provided.	Control board overloading. Faulty connection to one or more nodes. Faulty circuit boards.	Check that all boards are properly powered, installed, connected, and wired together. Check the condition of all circuit boards. Reduce control board loading. Contact the Danfoss supplier or the service department if the fault persists.
	4567	Restore Status	Provides information about the restore operation of a setting.	Event for logging.	No action.
	4568	Automatic Reset	All event conditions have cleared and triggered events have been automatically reset.	Event for logging.	No action.
	4816	PLC Task Overrun	The high CPU load is inhibiting normal operation of the application (PLC task overrun).	Software issue. Control board overloading. Faulty connection to one or more nodes. Faulty circuit boards.	Cycle power. Check that all boards are properly powered, installed, connected, and wired together. Check the condition of all circuit boards. Reduce control board loading. Contact the Danfoss supplier or the service department if the fault persists.
	4817	PLC Runtime Error	The PLC runtime has stopped responding. The application is halted.	Software issue. Control board overloading. Faulty connection to one or more nodes. Faulty circuit boards.	Cycle power. Check that all boards are properly powered, installed, connected, and wired together. Check the condition of all circuit boards. Reduce control board loading. Contact the Danfoss supplier or the service department if the fault persists.
	4832	Node Discovery	Node discovery and configuration are in progress. The modulation is inhibited.	Event for logging.	No action.
	4833	Node Commissioning	Nodes are being commissioned.	Event for logging.	No action.
	4834	Node Missing	A previously commissioned node is no longer available. The drive is waiting for the node to be available.	Node is without power. Connection to node is faulty.	Check that the node is powered on. Check the connection to the node. If the node is intentionally removed, recommission the drive.
	4851	Restart Required	A configuration change requires a soft-cycle or power-cycle to take effect. Modulation is inhibited.	Configuration change.	Soft- or power-cycle the drive.

Group	Number	Name	Description	Possible causes	Mitigation Actions
	4855	Internal Fault	An internal fault is detected related to temporal operations. Note the event number for further troubleshooting directions.	Software issue. Control board overloading. Faulty connection to one or more nodes. Faulty circuit boards.	Cycle power. Check that all boards are properly powered, installed, connected, and wired together. Check the condition of all circuit boards.
	4856	Internal Fault	An internal fault is detected related to asynchronous operations. Note the event number for further troubleshooting directions.		Reduce control board loading. Contact the Danfoss supplier or the service department if the fault persists.
	4857	Software Update	The drive is currently performing an update of the software.	Event for logging.	No action.
	5130	Quick Stop Event	A quick stop is requested.	A quick stop is requested, or the quick stop signal is faulty.	Check why quick stop was requested. Check the fieldbus or digital input signal health and connection.
	5140	Drive Interlocked	One or more interlocks is blocking the drive from starting. Remove the interlock and give a new start command.	An external system is inhibiting the drive from starting or running. Breaker control is inhibiting the drive from starting or running. The interlocking signal is faulty.	Check external system. Check the breaker control, its commands and feedback signals. Check the interlocking signal(s) for health of connectivity issues.
0x6180	5260	Event Simulation	The event with the number 5260 is simulated.	The event simulator was activated with its dedicated test event.	No action.
0x6181	4980	A Digital Input terminal is unknown by system	A digital input terminal is selected that is unknown by system.	An I/O option has been moved or removed.	Check I/O options. Reconfigure the function that is using the terminal in question.
	4981	A Digital Output terminal is unknown by system	A digital output terminal is selected that is unknown by system.		
	4982	An Analog Input terminal is unknown by system	An analog input terminal is selected that is unknown by system.		
	4983	An Analog Output terminal is unknown by system	An analog output terminal is selected that is unknown by system.		
	4984	A Digital Output terminal is occupied	A digital output is in use by another function or fieldbus. If a Fieldbus has taken control over a terminal, it has priority over parameter selection.	Several entities (fieldbus or I/O) have been configured to use the same terminal.	Reconfigure I/O and fieldbus functions to use their individual terminals.

Group	Number	Name	Description	Possible causes	Mitigation Actions
	4985	An Analog Output occupied	An analog output is in use by another function or fieldbus. If a Fieldbus has taken control over a terminal, it has priority over parameter selection.		
0x61f7	4800	Low Storage Space	The available storage space for the file system is low.	Too many parameter backups, data logger or event log files within the drive's file system.	Transfer parameter backups, logs and or data logger files to external memory to free up space.
	4801	Data Logger Storage	Volume restriction limits are preventing additional data logger capture files from being stored.	Low storage space. Demanding data logger settings.	Transfer files to external memory to free up space. Reduce the sampling time, logging window or amount of signals.
	4802	Event Logger Storage	Volume restriction limits are preventing additional event log capture files from being stored.	Low storage space.	Transfer files to external memory to free up space.
0x61fb	4600	Option Communication Fault	A fault of the communication with an option or other node is detected. Note the event number for further troubleshooting directions.	Faulty connection to the node. Faulty circuit boards.	Cycle power. Check that all boards are properly powered, installed, connected, and wired together. Check the condition of all circuit boards. Contact the Danfoss supplier or the service department if the fault persists.
	4601	Internal Communication Fault	An internal communication fault is detected in the auxiliary bus. Note the event number for further troubleshooting directions.		
	4602	Option Communication Fault	A fault of the communication with an option is detected.		
	4607	Internal Communication Fault	An internal communication fault is detected between different nodes. Note the event number for further troubleshooting directions.		
	4631	Internal Communication Fault	An internal communication fault to a power node is detected. Note the event number for further troubleshooting directions.		

Application Guide

Group	Number	Name	Description	Possible causes	Mitigation Actions
	4632	Internal Communication Fault	An internal communication fault to an optional node is detected. Note the event number for further troubleshooting directions.		
	4654	Control Node Disconnected	Internal communication route to one or more control nodes have been disconnected in a drive-to-drive system.	Control board or extender board is not powered. Faulty connection. Faulty control node or extender board.	Check the control board and associated extender board for power, connection, or defect issues.
0x61fc	4605	Internal Communication Fault	An internal communication fault is detected with high-speed bus to power system. Note the event number for further troubleshooting directions.	Faulty connection to the node. Faulty circuit boards.	Cycle power. Check that all boards are properly powered, installed, connected, and wired together. Check the condition of all circuit boards. Contact the Danfoss supplier or the service department if the fault persists.
	4606	Internal Communication Fault	An internal communication fault is detected. Cycle power, check the wiring if applicable, contact the Danfoss supplier or the service department if the fault persists. Note the event number for further troubleshooting directions.		
	4639	High Speed Bus Sync Error	Internal synchronization error detected with high-speed bus connection to parallel control unit.		
	4648	High Speed Bus Error	Internal error detected with high-speed bus connection to parallel control unit. Unexpected time adjustment.		
	4858	Internal Fault	An internal fault is detected. The power system has not received the required reference for modulation. Note the event number for further troubleshooting directions.		
	4859	Internal Fault	An internal fault (connection from power system) is detected.		

Group	Number	Name	Description	Possible causes	Mitigation Actions
			Note the event number for further troubleshooting directions.		
	4860	Unexpected Time Adjust	An internal fault (unexpected time adjustment) is detected. Note the event number for further troubleshooting directions.		
	4861	Synchronization Fault	An internal fault (time synchronization error between controller and power system) is detected. Note the event number for further troubleshooting directions.		
	4862	PDS	Internal error detected with high-speed bus connection from controller.		
	4863	Internal Fault	An internal fault (connection with power system) is detected. Note the event number for further troubleshooting directions.		
0x61FF	4609	IO Failure Detected	An I/O Failure was detected.	The Safe Torque Off (STO) is activated due to a discrepancy fault.	Check the health and connection of the STO signals and the Functional Safety module.
0x6320	4350	Configuration Error	An invalid system configuration is detected.	Incompatible motor type and control principle.	Check motor type and motor control principle.
	5301	Invalid Control Config.	An invalid control configuration is preventing operation.	Too narrow DC-link voltage bandwidth.	Check DC-link voltage controller levels.
	5302	Start Blocked	Motor control, interlocking or stop commands are preventing the drive from stopping.	Motor control is not ready. External systems or breaker control is applying interlocks. A stop command is active. Faulty signals or configurations associated with the	Check the Motor Ctrl. Ready Status Word for the cause.

Application Guide

Group	Number	Name	Description	Possible causes	Mitigation Actions
				preceding factors.	
0x7080	5220	Brake Feedback Wrong State	Mechanical brake feedback is in a wrong state. Feedback state should reflect state of brake, except during opening or closing phases.	Faulty feedback signal. Brake was externally controlled to wrong state.	Check the feedback signal(s) for health or connectivity issues. Check external brake control sources.
	5221	Brake Priming Timeout	Brake priming has timed out. The drive could not produce the configured priming torque to open the brake safely.	Incorrect priming torque or timing settings.	Adjust the priming parameterization.
	5222	Brake Feedback Timeout	Brake feedback has timed out. The feedback signal is indicating that the mechanical brake has not opened or closed within the configured time.	Faulty feedback signal. Incorrect closing or opening time settings.	Check the feedback signal(s) for health or connectivity issues. Adjust the brake opening and closing settings based on brake opening and closing times.
	5223	Brake Closed: High DC Voltage	The mechanical brake was closed and the drive stopped due to high DC voltage, likely resulting from high back EMF of the motor.	Excessive generative power due to braking of load or freewheeling load.	
	5224	Inhibited Stop Protection	The inhibited stop protection acted and closed the mechanical brake because the drive was not able to stop within the given brake closing delay.	Generative torque limit does not match the application specifications.	Apply less regenerative torque limit or reduce deceleration time.
0x7081	5128	Motor Breaker Supervision	Motor Breaker Supervision has detected a discrepancy between commands and feedback.	Breaker command was not sent. Breaker feedback was not received. Feedback signal was lost. Too short monitoring delay.	Check the connection, health, and configuration of the breaker command signal(s). Check the connection, health, and configuration of the breaker feedback signal(s). Adjust the monitoring delay based on breaker closing and opening time.
0x70ff	4128	Control Fan Failure	The control board cooling fan is not running at the commanded speed.	Blocked or faulty fan. Faulty fan wiring.	Check the fan's wiring and whether its blocked or polluted. Replace the fan if necessary.
	4129	Main Fan Failure	The main cooling fan is not following its		

Application Guide

Group	Number	Name	Description	Possible causes	Mitigation Actions
			reference speed.		
	4130	Internal Fan Failure	The internal fan is running below its reference speed. Check the fan's wiring and whether its blocked or polluted. Replace the fan if necessary.		
	4133	LCL Fan Speed Fault	LCL cooling fan not tracking commanded output.		
0x7110	5204	Brake Resistor Test Active	The Brake Resistor Test is active. Normal run of the drive is not possible.	Event for logging.	No action.
	5205	Brake Resistor Test Failed	The Brake Resistor Test was unsuccessful.	Faulty brake resistor or connection.	Check the brake resistor and its connections.
	5206	Brake Resistor Test Successful	The test of the brake resistor is performed successfully.	Event for logging.	No action.
0x7111	4403	Brake Ch. Switch Shorted	A short circuit of the brake chopper switch is detected, which can be dangerous. Disconnect power. Service is required.	Defective components.	Service the brake chopper.
0x7113	4400	Brake Chopper Overload	A brake chopper overcurrent is detected.	Brake size mismatch to application. Overloading of resistor.	Cycle Power. Reduce the brake voltage level and check the rating of the brake resistor.
	4401	Brake Resistor Temp. High	The brake resistor temperature is too high.	Brake size mismatch to application. Insufficient cooling. Overloading of resistor.	Check the rating of the brake resistor and cooling conditions. Reduce the generated regenerative power.
	4402	Brake Resistor Missing	The brake resistor or its connection is missing.	Faulty brake resistor connection.	Check the resistor and connections for installation issues or defects.
	4404	Brake Failure	A brake failure is detected, further testing will clarify the failure source. Coast first to run the test.	Defective brake or connections.	Run the brake test.
0x7120	4177	Motor Thermal Overload	A thermal overload of the motor is detected.	Motor current or torque is too high.	Check if torque, power or current should be limited.
	4178	Motor Speed High	The motor speed is above the normal operating range.	Motor torque is too high.	Check if torque, power or current should be limited.
	4179	AMA Current Low	The nominal current of the motor is too low for	Motor nominal parameters don't	Check motor nominal parameters.

Application Guide

Group	Number	Name	Description	Possible causes	Mitigation Actions
			accurate results of automatic motor adaptation (AMA).	correspond with the motor. Output current is too limited.	Check limitation parameters.
	4180	Rotor Angle Detection Error	Rotor angle detection has failed.	This might be as the motor is not suited to the drive or the motor is missing.	Check the motor nominal parameters. Check the motor connection to the drive.
	4181	Low Motor Saliency For High Frequency Injection Mode	Motor saliency is too low for HF injection mode.	Incorrect motor data.	Check the motor data.
	4382	Blocked Rotor	The rotor is blocked.	Motor shaft is jammed.	Inspect the motor shaft.
	5146	Stall Protection Acted	Motor stall protection acted because the motor current exceeded the given stall current limit, and the motor speed was below the given stall speed limit for the given stall time.	Motor shaft is jammed.	Inspect the motor shaft. Inspect the load.
	5200	AMA Active	The AMA (Automatic Motor Adaptation) is active. Normal run of the motor is not possible. Apply a start signal to run the AMA.	Event for logging.	No action.
	5201	AMA Motor Data	The motor data measurement of the AMA (Automatic Motor Adaptation) was unsuccessful.	Motor nominal parameters don't correspond with the motor. Output current is too limited.	Check motor nominal parameters. Check limitation parameters.
	5202	AMA Motor Type	The motor type detection of the AMA (Automatic Motor Adaptation) was unsuccessful.		
	5203	AMA Successful	The AMA (Automatic Motor Adaptation) is performed successfully.	Event for logging.	No action.
	5300	Invalid Motor Data	Invalid motor data is preventing operation.	Motor parameters are insensible.	Check the motor nominal parameters, motor type, voltage class and motor control principle.
0x7122	4182	Motor Sync Loss	Synchronization between motor and drive is lost. This is only relevant when using a permanent magnet or synchronous reluctance motor.	Fault in the motor or motor shaft is blocked. Fault in the feedback device. Limits are too strict.	Check the motor and motor shaft. Check the feedback device. The limit settings.
0x72ff	4417	Feedback Option Fault	The Feedback Option is indicating a fault	Fault in the feedback option.	Check the option itself, the wiring to the option

Application Guide

Group	Number	Name	Description	Possible causes	Mitigation Actions
			condition.		and the condition of the feedback device.
0x7300	4207	Sensor Configuration	A sensor configuration error is detected.	A sensor is either missing, not expected, or incorrectly connected.	Check the sensor connection and status.
0x7310	4418	Bad Speed Feedback	Speed Feedback value is not reliable.	Fault in the feedback option. Fault in the feedback device. Feedback option misconfiguration,	Check the option itself, the wiring to the option and the condition of the feedback device. Check the feedback device settings.
0x7500	4638	Drive to Drive Connection Lost	Drive to drive connection is lost.	Fault in the connection between drives. Fault in the extender board.	Check the connection between the drives. Check the status of the extender boards.
0x7502	4416	Analog Input Live Zero	A live zero event detected in an analog input terminal.	A faulty wire or connection.	Check the analog input wiring or connections.
0x7580	5141	Control Panel Connection Lost	The connection to the control panel was lost. Panel control is released.	Fault in the panel connection. Error in the panel.	Check the connection to the panel. Check the panel.
	5142	PC Tool Connection Lost	The connection to the PC tool was lost. PC control is released.	Fault in the PC connection. Error in the PC software or software was closed.	Check the connection to the PC. Check the status of the PC software.
0x8080	5125	Limit Supervision Event 1	A selected signal is over/under a supervision limit.	The drive is in an undesirable operating point.	Check the operating point. Consider applying speed, current, torque or power limits.
	5126	Limit Supervision Event 2			
	5127	Limit Supervision Event 3			
0x8100	4256	Address Conflict	The fieldbus has identified an Address Conflict on the network which made the device back off.	Two or more devices in the service or fieldbus networks have the same address.	Change the address of the conflicting devices.
	4257	Ethernet Cable Fault	At link down a measurement is done to measure the distance to the far end of the cable, indicating where the fault has occurred. This warning occurs at distances > 4 m and Link State Change Down. Actual distance shown in detailed info.	The service or fieldbus ethernet connection is faulty due to cable or connection issues.	Check the cables and connections. Utilize the detailed event info.
	4258	Invalid Fieldbus Configuration	An issue due to an invalid configuration of the fieldbus connection	Features not supported by the device. Mismatch between	Depending on the protocol: Check the custom

Application Guide

Group	Number	Name	Description	Possible causes	Mitigation Actions
			is detected. See additional detail info.	configured and available features. Modules not available in the device.	Modbus® mapping. Check for mismatches in the used device and device description files.
	4260	Redundant Controller Missing	One or more of the expected fieldbus controllers are missing.		Check the fieldbus connection or the status of the fieldbus master.
	4261	Fieldbus Topology Mismatch	The current fieldbus topology does not match the topology provided at commissioning time.	Wiring mistake. Fieldbus master configuration mistake.	Reconfigure the fieldbus master or change the connection between X1/X2 ports.
	4263	Ethernet Link Status Changed	A change of the Ethernet link status is detected. Additional info has details about which port and state.	Event for logging.	No action.
	4265	Ethernet Redundancy Error	Primary or backup physical paths is missing.	Connection or cable fault. Wrong interface settings	Check the connection. Check the interface settings.
	4266	X1 Cable Redundancy	Indicates that physical path from X1 interface to the controller is missing or wrongly configured.		
	4267	X2 Cable Redundancy	Indicates that physical path from X2 interface to the controller is missing or wrongly configured.		
	4269	Network Time Protocol	Information of Network Time Protocol server. See detailed info.	Event for logging.	No action.
	4280	Controller Not in Run	Controller not in RUN state.	Event for logging.	No action.
	4281	Interface Configuration Change	Interface configuration changed. See detailed info.	Event for logging.	No action.
0x8100	5161	Fieldbus Watchdog Supervision	Fieldbus watchdog supervision has detected too long delay between fieldbus data updates.	Fieldbus master has lost control, or the current transferred I/O data from the master is not valid. The fieldbus master is not updating the data.	Check the fieldbus connection, the status of any ethernet switches or the status of the fieldbus master.
0x8100	5163	Primary Process Data Timeout	The fieldbus I/O data has not been updating any of the process data monitored by the primary process data monitor (Watchdog1).	This can happen when the direct fieldbus connection to the drive has lost control, or the current received I/O data is not valid.	Check the fieldbus connection directly to the drive or the status of the fieldbus master.
0x8100	5165	Fieldbus Faulted	One or more of the	An established Fieldbus	Check the fieldbus

Application Guide

Group	Number	Name	Description	Possible causes	Mitigation Actions
			Fieldbus I/O connections has failed from any protocol.	I/O Connection is disrupted by, for example, a cable break or power cut of PLC or other infrastructure components.	connection or the status of the fieldbus master.
0x81fd	4270	No Modbus® TCP Connection	No Modbus® TCP communication is currently established.	Can happen during start-up until first connection is established or if all connections have stopped (gracefully or disruptive).	Establish a connection.
	4271	No PROFINET® Connection	No PROFINET® I/O communication is currently established.		
	4272	No EtherNet/IP® Connection	No EtherNet/IP® communication is currently established.		
	4273	No EtherCAT® Connection	No EtherCAT® communication is currently established.		
	4282	No Modbus® TCP Connection	No Modbus® RTU communication is currently established.		
0x81fe	4274	Loss of Modbus TCP I/O	One or more of the Fieldbus I/O connections has failed.	Event for logging.	No action.
	4275	Loss of PROFINET® I/O			
	4276	Loss of EtherNet/IP® I/O			
	4277	Loss of EtherCAT® Connection			
	4283	Loss of Modbus® RTU Connection			
0x81ff	4278	Primary Process Data Timeout	The fieldbus I/O data has not been updating any of the process data monitored by the primary process data monitor (Watchdog1/2).	Event for logging.	No action.
	4279	Secondary Process Data Timeout			
0x8400	5131	Speed Error	Feedback differs too much from request.	The motor is out of synchronization. The feedback device is not properly connected to the motor. Limits are too strict.	Check the motor. Check the feedback device. Check limit settings.
0x9080	5230	Lost Load Detected	Drive is not detecting any load on the motor shaft.	The motor is disconnected from the load.	Check the motor shaft.
0xf004	5270	Inertia Estimation Active	The drive is ready for performing the Inertia Estimation. A start command is required.	Event for logging.	No action.
	5271	Inertia Estimation Failed	The Inertia Estimation failed.	Motor nominal parameters don't correspond with the motor.	Check motor nominal parameters. Check limitation parameters.

Application Guide

Group	Number	Name	Description	Possible causes	Mitigation Actions
				Output current is too limited.	
	5272	Inertia Estimation Successful	Inertia Estimation is performed successfully.	Event for logging.	No action.
0xff01	5123	External Event 1	An external signal has activated an event.	An external system is requesting for the drive to log an event or to stop running. The event triggering signal is faulty.	Check the external system. Check the health of the signal.
	5124	External Event 2			
0xff06	5901	Logic Input Error	Configured input function reports an error.	Warning event. There is an issue with one or more input signals of one or more logic function blocks. Warning event. There is an issue with one or more output signals of one or more logic function blocks. Warning event. One or more logic function blocks have been configured incorrectly. Warning event. One or more logic states have been configured incorrectly.	Change the logic configuration. Check the <i>MyDrive® Insight Logic Feature Application Guide</i> for more information.
	5902	Logic Output Error	Configured output function reports an error.		
	5903	Logic Block Configuration Error	Logic block configuration is incorrect.		
	5904	Logic State Error	Logic state handling reports an error.		



Danfoss A/S
Ulsnaes 1
DK-6300 Graasten
drives.danfoss.com

Any information, including, but not limited to information on selection of product, its application or use, product design, weight, dimensions, capacity or any other technical data in product manuals, catalog descriptions, advertisements, etc. and whether made available in writing, orally, electronically, online or via download, shall be considered informative, and is only binding if and to the extent, explicit reference is made in a quotation or order confirmation. Danfoss cannot accept any responsibility for possible errors in catalogs, brochures, videos and other material. Danfoss reserves the right to alter its products without notice. This also applies to products ordered but not delivered provided that such alterations can be made without changes to form, fit or function of the product. All trademarks in this material are property of Danfoss A/S or Danfoss group companies. Danfoss and the Danfoss logo are trademarks of Danfoss A/S. All rights reserved.

M00380
AB426216167632en-010801
Danfoss A/S © 2026.04

