

Fact sheet

AB-QM flow checker DN 40-250 and AB-QM 4.0 DN 15-32

Verifying the flow on AB-QM valves

Flow verification in an installation

To verify that an installation functions according to the design specifications checking only the most critical valve in the installation is needed (see figure 1).

The AB-QM maintains a constant differential pressure over the valve and any excess pressure will automatically be throttled. If there is not enough differential pressure the valve cannot reach the set flow.

The valve that is furthest away from the pump or the valve in the circuit with the highest resistance has the lowest available differential pressure, so if this critical valve has enough pressure it means the other valves will also function properly.

Important:

To get a useful measurement the installation should run on full load, so all actuators in the installation should be opened fully. This ensures that you are measuring under the most unfavorable circumstances. The AB-QM's will have more differential pressure available when the installation is working on partial load.

To get useful measurement the commissioning zone should run on full load, so all actuators in the installation should be opened fully. Please check if coincidence factor was taken into consideration.

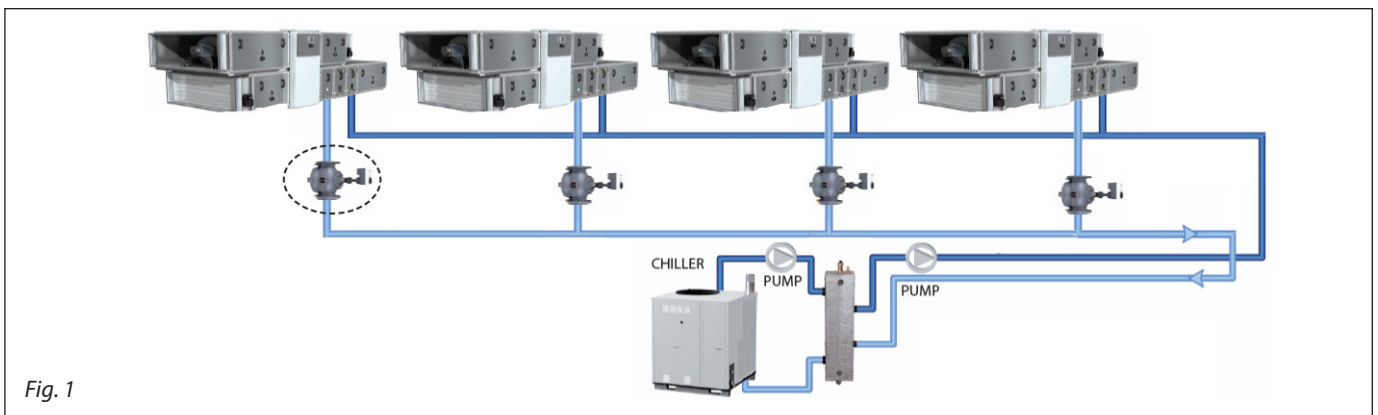


Fig. 1

Method of verification

AB-QM DN 40-250

Measure the differential pressure across the whole valve.

The test plugs are placed in such a way that differential pressure p_1-p_3 (Δp) over the valve is measured (see figure 2).

If the measured value is below dp_{min} then there is not enough differential pressure available for the AB-QM to function properly. If the measured value is above dp_{min} then the AB-QM has enough differential pressure available and the flow is according to the setting (see figure 3).

Setting the flow

DN 40-100: 1 turn=10 %
 DN 125-150: 1,5 turn=8 %
 DN 125-150: 3 turn=16 %
 DN 200-250: 3 turn=12,5 %
 DN 200-250: 6 turn=25 %

Note: for more information about setting procedure please refer to instructions

Method of measurement

AB-QM DN 40-250
 AB-QM 4.0 DN 15-32

Measure the differential pressure across the control valve.

The test plugs are placed in such a way that p_1-p_2 is measured (see figure 2).

Therefore the measured differential pressure can be used to calculate the flow directly. It's necessary to use the table that was derived from statistical measurements

Since the measurements across the measuring points are influenced by the dynamic pressure, turbulences, flow patterns, internal tolerances, setting accuracy and accuracy of the measuring

equipment we believe that the total accuracy of the measurement is lower than performance of the valve.

Therefore we recommend not to adjust the setting when the results are within 10 % of the expected flow.

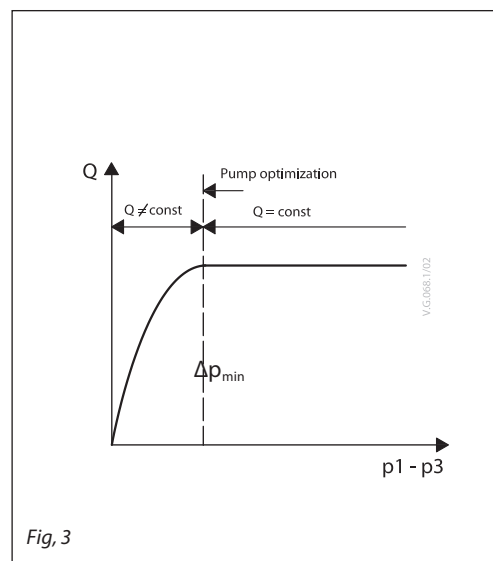
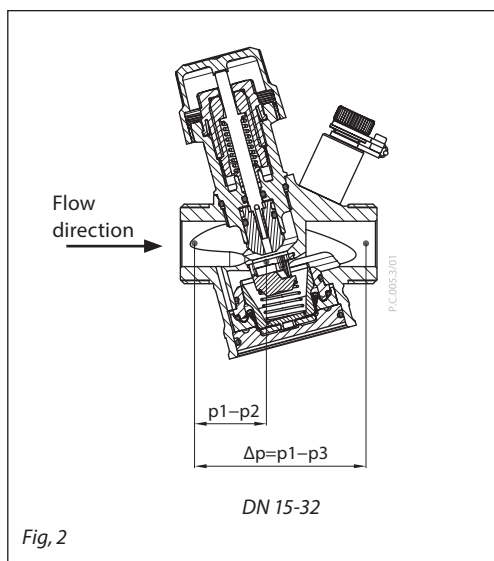
Calculating the flow

$$\Delta p_{cv} = p_1 - p_2$$

$$Q = kv_{cv} \times \sqrt{\Delta p_{cv}}$$

For kv_{cv} values see tables in figure 4 and 7

AB-QM 4.0 DN 15-32



	DN 15LF	DN 15NF	DN 15HF	DN 20NF	DN 20HF	DN 25NF	DN 25HF	DN 32NF	DN 32HF
Δp_{min} (kPa) ¹⁾	16	16	25	16	25	20	30	30	30
Presetting (%)	kv_{cv} (m ³ /h)								
10,00	0,048	0,115	0,26	0,169	0,42	0,59	0,77	1,17	1,31
12,50	0,057	0,152	0,34	0,225	0,53	0,74	0,97	1,40	1,57
15,00	0,070	0,189	0,41	0,290	0,65	0,89	1,16	1,62	1,83
17,50	0,082	0,221	0,48	0,354	0,75	1,04	1,36	1,85	2,09
20,00	0,093	0,256	0,54	0,428	0,86	1,19	1,55	2,07	2,36
22,50	0,102	0,290	0,61	0,501	0,96	1,34	1,76	2,32	2,64
25,00	0,110	0,325	0,68	0,575	1,06	1,49	1,97	2,57	2,93
27,50	0,115	0,360	0,75	0,655	1,17	1,63	2,17	2,81	3,23
30,00	0,120	0,395	0,82	0,735	1,28	1,78	2,38	3,06	3,54
32,50	0,124	0,435	0,90	0,815	1,40	1,93	2,62	3,33	3,86
35,00	0,129	0,475	0,97	0,888	1,50	2,10	2,86	3,59	4,17
37,50	0,134	0,515	1,04	0,960	1,60	2,27	3,10	3,86	4,49
40,00	0,142	0,560	1,11	1,038	1,69	2,43	3,33	4,15	4,81
42,50	0,149	0,605	1,17	1,116	1,79	2,60	3,56	4,45	5,13
45,00	0,159	0,655	1,24	1,194	1,89	2,77	3,79	4,74	5,47
47,50	0,169	0,705	1,32	1,272	1,98	2,92	4,02	5,04	5,80
50,00	0,179	0,755	1,39	1,350	2,08	3,07	4,25	5,33	6,13
52,50	0,192	0,810	1,46	1,430	2,17	3,22	4,45	5,61	6,45
55,00	0,205	0,865	1,53	1,510	2,22	3,36	4,66	5,89	6,76
57,50	0,221	0,920	1,60	1,590	2,26	3,51	4,86	6,17	7,09
60,00	0,236	0,975	1,67	1,670	2,29	3,66	5,07	6,46	7,39
62,50	0,252	1,030	1,73	1,750	2,33	3,80	5,27	6,74	7,69
65,00	0,270	1,090	1,79	1,834	2,36	3,95	5,45	7,02	7,97
67,50	0,287	1,150	1,85	1,918	2,40	4,09	5,63	7,30	8,24
70,00	0,305	1,207	1,90	2,002	2,44	4,24	5,81	7,53	8,53
72,50	0,322	1,263	1,96	2,086	2,47	4,38	5,99	7,76	8,77
75,00	0,340	1,320	2,01	2,170	2,51	4,52	6,17	7,99	9,03
77,50	0,356	1,366	2,08	2,233	2,56	4,67	6,34	8,22	9,26
80,00	0,372	1,412	2,14	2,297	2,61	4,81	6,50	8,45	9,46
82,50	0,388	1,458	2,18	2,360	2,66	4,96	6,67	8,63	9,68
85,00	0,404	1,504	2,22	2,423	2,72	5,10	6,83	8,80	9,90
87,50	0,420	1,550	2,27	2,486	2,79	5,22	7,00	8,98	10,06
90,00	0,432	1,586	2,33	2,549	3,13	5,33	7,11	9,15	10,28
92,50	0,444	1,622	2,40	2,600	3,47	5,45	7,22	9,33	10,43
95,00	0,457	1,658	2,48	2,640	3,55	5,57	7,33	9,50	10,57
97,50	0,469	1,694	2,53	2,680	3,64	5,68	7,44	9,68	10,74
100,00	0,481	1,730	2,60	2,720	3,73	5,80	7,55	9,85	10,84

¹⁾ At min differential pressure valve reaches at least 90% of nominal flow. Declaration of performance is available upon request.

Fig. 4 The flow is according to setting if the calculated flow is in the range of ±10 % of the set flow.

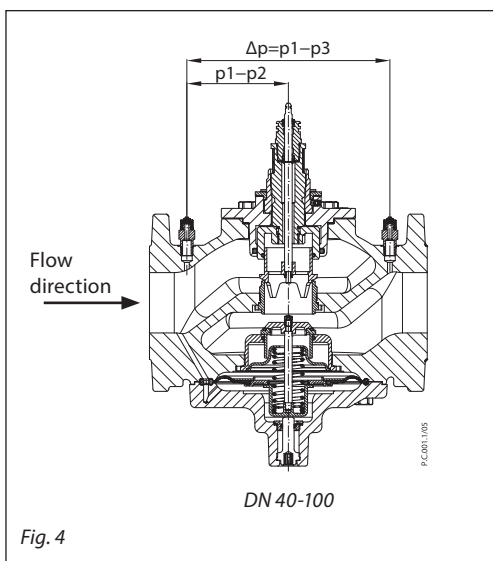
AB-QM DN 40-100


Fig. 4

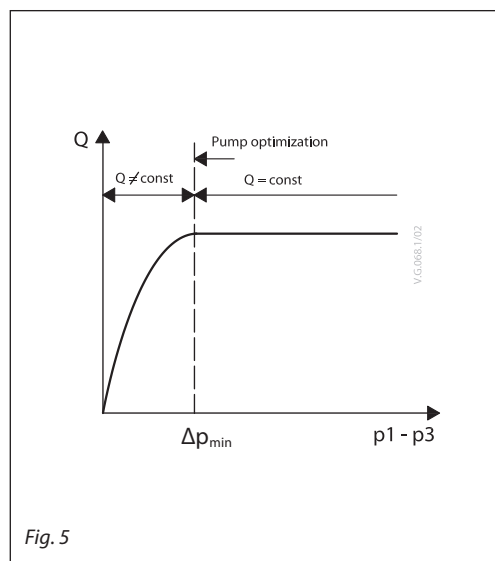


Fig. 5

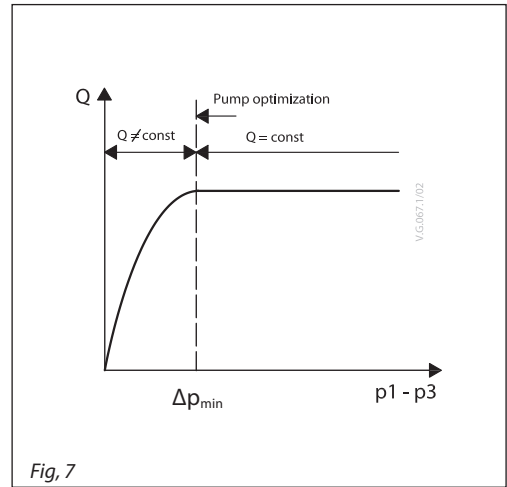
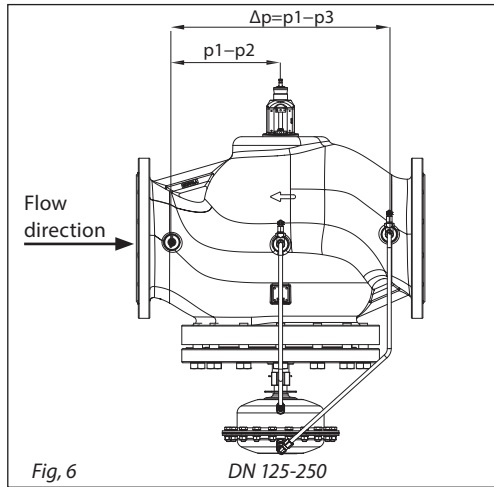
	DN 40	DN 50/DN 50HF	DN 65	DN 65HF	DN 80	DN 80HF	DN 100	DN 100HF
Δp_{\min} (kPa) ¹⁾	30	30	30	60	30	60	30	60
Presetting (%)	kv_{cv} (m³/h)							
20,00	3,40	4,60	4,20			15,50		19,50
22,50	4,08	5,55	5,48			17,19		21,94
25,00	4,80	6,50	6,75			18,88		24,38
27,50	5,43	7,45	8,03			20,56		26,81
30,00	6,10	8,40	9,30			22,25		29,25
32,50	6,78	9,35	10,58			23,94		31,69
35,00	7,50	10,30	11,85			25,63		34,13
37,50	8,13	11,25	13,13			27,31		36,56
40,00	8,80	12,20	14,40			29,00		39,00
42,50	9,48	13,15	15,68			30,69		41,44
45,00	10,20	14,10	16,95			32,38		43,88
47,50	10,83	15,05	18,23			34,06		46,31
50,00	11,50	16,00	19,50			35,75		48,75
52,50	12,18	16,95	20,78			37,44		51,19
55,00	12,90	17,90	22,05			39,13		53,63
57,50	13,53	18,85	23,33			40,81		56,06
60,00	14,20	19,80	24,60			42,50		58,50
62,50	14,88	20,75	25,88			44,19		60,94
65,00	15,55	21,70	27,15			45,88		63,38
67,50	16,26	22,65	28,43			47,56		65,81
70,00	16,90	23,60	29,70			49,25		68,25
72,50	17,58	24,55	30,98			50,94		71,81
75,00	18,25	25,50	32,25			52,63		75,38
77,50	18,93	26,45	33,53			54,31		78,94
80,00	19,60	27,40	34,80			56,00		82,50
82,50	20,28	28,35	36,08			57,69		86,06
85,00	20,95	29,30	37,35			59,38		89,63
87,50	21,63	30,25	38,63			61,06		93,19
90,00	22,30	31,20	39,90			62,75		96,75
92,50	22,98	32,15	41,18			64,44		100,31
95,00	23,65	33,10	42,45			66,13		103,88
97,50	24,33	34,05	43,73			67,81		107,44
100,00	25,00	35,00	45,00			69,50		111,00

¹⁾ At min differential pressure valve reaches at least 90% of nominal flow. Declaration of performance is available upon request.
 Fig. 5 The flow is according to setting if the calculated flow is in the range of $\pm 10\%$ of the set flow.

Fact sheet

AB-QM flow checker DN 40-250 and AB-QM 4.0 DN 15-32

AB-QM DN 125-250



	DN 125	DN 125HF	DN 150	DN 150HF	DN 200	DN 200HF	DN 250	DN 250HF	DN 250SHF	DN 250 SHF+
Δp_{min} (kPa) ¹⁾²⁾	40	60	40	60	45	60	40	60	80	100
Presetting (%)	kv_{cv} (m ³ /h)									
20,00	37,0		55,0		105,0				110,0	
22,50	42,6		62,5		119,4				128,7	
25,00	48,1		70,0		133,7				147,5	
27,50	53,7		77,5		148,1				166,2	
30,00	59,2		85,0		162,5				185,0	
32,50	64,8		92,5		176,9				203,7	
35,00	70,4		100		191,2				222,5	
37,50	75,9		107,5		205,6				241,2	
40,00	81,5		115,0		220,0				260,0	
42,50	85,3		120,6		231,3				277,5	
45,00	89,1		126,3		242,5				295,0	
47,50	92,9		131,9		253,8				312,5	
50,00	96,8		137,5		265,0				330,0	
52,50	100,6		143,1		276,3				347,5	
55,00	104,4		148,8		287,5				365,0	
57,50	108,2		154,4		298,8				382,5	
60,00	112,0		160,0		310,0				400,0	
62,50	118,0		166,5		323,8				415,0	
65,00	124,0		173,0		337,5				430,0	
67,50	130,0		179,5		351,3				445,0	
70,00	136,0		186,0		365,0				460,0	
72,50	142,0		192,5		378,8				475,0	
75,00	148,0		199,0		392,5				490,0	
77,50	154,0		205,5		406,3				505,0	
80,00	160,0		212,0		420,0				520,0	
82,50	165,6		219,3		435,0				542,5	
85,00	171,3		226,5		450,0				565,0	
87,50	176,9		233,8		465,0				587,5	
90,00	182,5		241,0		480,0				610,0	
92,50	188,1		248,3		495,0				632,5	
95,00	193,8		255,5		510,0				655,0	
97,50	199,4		262,8		525,0				677,5	
100,00	205,0		270,0		540,0				700,0	

¹⁾ At min differential pressure valve reaches at least 90% of nominal flow. Declaration of performance is available upon request.

²⁾ When set above 100 %, minimum starting pressure needed is higher, see figures in the ().

Fig. 7 The flow is according to setting if the calculated flow is in the range of ±10 % of the set flow.

Danfoss A/S

Climate Solutions • danfoss.com • +45 7488 2222

Any information, including, but not limited to information on selection of product, its application or use, product design, weight, dimensions, capacity or any other technical data in product manuals, catalogues descriptions, advertisements, etc. and whether made available in writing, orally, electronically, online or via download, shall be considered informative, and is only binding if and to the extent, explicit reference is made in a quotation or order confirmation. Danfoss cannot accept any responsibility for possible errors in catalogues, brochures, videos and other material. Danfoss reserves the right to alter its products without notice. This also applies to products ordered but not delivered provided that such alterations can be made without changes to form, fit or function of the product.

All trademarks in this material are property of Danfoss A/S or Danfoss group companies. Danfoss and the Danfoss logo are trademarks of Danfoss A/S. All rights reserved.