

Operating guide

Energy Recovery Device

MPE S 70

Installation, Operation and Maintenance Manual



Table of Contents	1	Validity	4
	2	Introduction	5
	2.1	General	5
	2.2	Target group	5
	2.3	Symbols	5
	2.4	Manufacturer and customer service address	5
	2.5	Country specific information	5
	2.5.1	United Kingdom	5
	2.6	Additional technical documents	5
	3	Safety	7
	3.1	General	7
	3.2	Intended use	8
	3.3	Application range	8
	3.4	Preferred system design	8
	3.5	Initial start-up and settings of safety equipment	8
	3.6	Over-pressurisation caused by low pressure isolation	8
	4	Arrival inspection, handling and storage	9
	4.1	Arrival inspection	9
	4.2	Return to the supplier	9
	4.3	Transport and Handling	9
	4.4	Storage	10
	5	Technical data and design details	11
	5.1	Design details	11
	5.2	Sound level of the MPE S 70	11
	5.3	Materials	12
	5.4	Temperature and corrosion	12
	5.5	Dimensions and weights	12
	5.6	Electrical motor data	12
	5.7	How does the MPE S 70 work?	13
	6	Operation and Controls	14
	6.1	Initial start-up and flushing	14
	6.2	Air bubbles	15
	6.3	Start-up sequence	15
	6.4	Shut-down sequence	15
	6.5	High pressure remains after shutdown	15
	6.6	CIP or membrane cleaning	15
	6.7	Flushing	16
	6.8	Seawater quality	16
	6.8.1	Pre-filtration	16
	6.8.2	Chemicals	16

7	On-site installation	17
7.1	Design details	17
7.2	Assembly MPE S 70 to electric motor	17
7.3	Danfoss Offers rail and Bracket solution	17
7.4	Orientation	17
7.5	Piping and joints	17
7.6	Accessibility	17
7.7	Motor and frequency converter	18
7.7.1	Electric motor	18
7.7.2	Starting torque for the MPE S 70	18
7.7.3	Frequency converter	18
8	Commissioning, start-up and shutdown	19
8.1	Safety regulations	19
8.2	Support	19
8.3	Commissioning	19
9	Service/Maintenance	20
9.1	Safety regulations	20
9.2	Support	20
9.3	Maintenance schedule	20
9.4	Recommended service intervals for MPE S 70	21
9.5	Recommended service for electric motor	21
10	Trouble-shooting	22
10.1	Safety regulations	22
11	Appendix	23
11	Appendices	23
11.1	Data sheet MPE S 70 (AI551439122001en-000101)	25
11.2	Instruction (AN367027298445en-000202)	39
11.3	Design guide Pipe connections (180R9367)	51
11.4	MPE S 70 part list (AX367028596447en-000304)	53
11.5	Operating- and maintenance instruction, electric motor (180R9230)	59

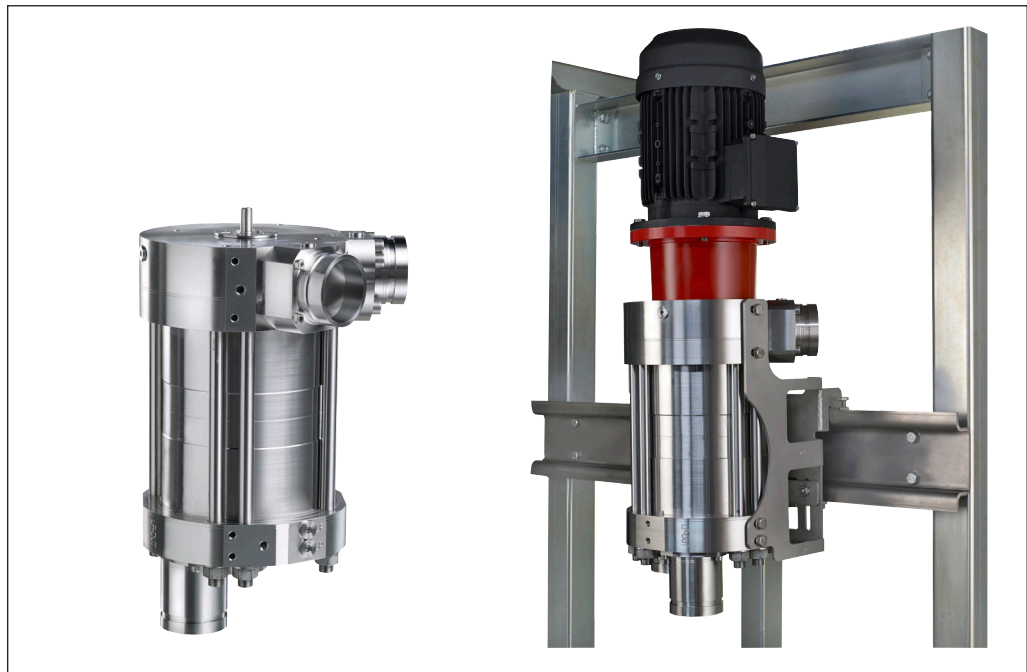

1. Validity

Document information and copyright

Installation, Operation and Maintenance Manual.

Danfoss can accept no responsibility for possible errors in the manual and instructions. Danfoss reserves the right to alter its products without notice. This also applies to products already on order provided that such alterations can be made without subsequential changes being necessary in specifications already agreed. All rights reserved. Contents provided herein must neither be distributed, copied, reproduced, edited or processed for any other purpose, nor otherwise translated or published without Danfoss' express written consent.

Validity

This manual is valid for MPE S 70

Description	Code no.	Serial no.
MPE S 70 without motor	180F7171	XXXXXX01-XXX
MPE S 70 (IEC motor)	180F7066	XXXXXX01-XXX

ERD
 Type MPE S 70
 Code no. 180F7171
 Serial no. XXXXXX01-XXX



MADE IN DENMARK



Danfoss A/S, 6430 Nordborg, Denmark

The serial number is referring to the Serial no. on the product label. The digits shown (01) indicate the version number of the pump.
 This document is only valid for MPE version 1 and upwards.

2. Introduction

2.1 General

MPE S 70 is manufactured by Danfoss A/S, and is sold and marketed by a net of authorised distributors world wide.

This manual contains the necessary instructions for the installation, operation and service of the MPE S 70.

 **All personnel who are responsible for the operation and maintenance of the MPE S 70 unit must read and fully understand these instructions, especially the section “Safety” before:**

- **Transporting of the MPE S 70 unit.**
- **Lifting the unit.**
- **Installing the MPE S 70 unit on a frame.**
- **Connecting the MPE S 70 unit to the fluid system.**
- **Connecting the electrical motor and instrumentation.**
- **Commissioning the unit.**
- **Servicing the MPE S 70 unit, mechanics and electrics.**
- **Decommissioning the MPE S 70 unit.**

 Ensure that these instructions are always readily available to all personnel concerned.

2.2 Target group

This manual is intended for use by personnel with qualified training and experience in the operation and maintenance of a Sea Water Reverse Osmosis (SWRO) or Brackish Water Reverse Osmosis (BWRO) system.

If the recommendations in the manual are not followed, Danfoss reserves the right to void the warranty.

2.3 Symbols

-  Indicates something to be noted by the reader.

-  Indicates a situation which will or could result in damage to the MPE S 70 and its function.

-  Indicates a situation which will or could result in personal injury and/or damage to the MPE S 70.

-  Electrical hazard. Indicates a high-voltage warning

-  Safety glasses required

-  Hearing protection required

-  Safety shoes required

-  Safety helmet required

2.4 Manufacturer and customer service

Danfoss A/S
 High Pressure Pumps
 DK-6430 Nordborg, Denmark
 Telephone: +45 7488 2222
 Email: highpressurepumps@danfoss.com
 Homepage: hpp.danfoss.com

2.5 Country specific information

2.5.1 United Kingdom

UK importer:
 Danfoss Ltd.
 22 Wycombe End
 HP9 1NB Beaconsfield
 United Kingdom

2.6 Additional technical documents

Below documents are not present in this Operating guide. Please contact Danfoss.

Document name	Content
Service guide: "MPE S 70 Disassembling and assembling"	Description of how to disassemble and assemble the MPE S 70
Guide line: "P and ID review sheet"	Detailed description about the need for each individual component in the preferred P&ID
Quick guide for FC51 ; "MG02BC02"	Description on how to setup Danfoss frequency controller type FC 51

3. Safety

3.1 General

The MPE S 70 must not be used for other purposes than those recommended and specified without first consulting your local MPE S 70 distributor.

This manual must be read and completely understood by the responsible specialist personnel prior to installation and commissioning.

Use of this manual does not relieve operation and maintenance personnel of the responsibility of applying normal good judgment in the operation and care of this product and its components.

This manual must be available to all personnel concerned at the site at all time.

An MPE S 70 must always be installed and used in accordance with existing national and local sanitary and safety regulations and laws. It is the responsibility of the safety officer or the chief operator to assure compliance with all local regulations that are not taken into account in this manual.

The MPE S 70 is a rotating machine that typically operates at high pressure.



Always wear suitable safety and lifting equipment when handling the MPE S 70.



- Bolt the MPE S 70 properly to the frame before start-up to avoid personal injury and/or damage to the MPE S 70.
- The pipe connections to the MPE S 70 must be stress-free mounted, securely fastened to the MPE S 70 and well supported. Improper installation will or could result in personal injury and/or damage to the MPE S 70.
- Proper installation and care of shutdown devices and over-pressure protection equipment is essential.



- All electrical installation work must be carried out by authorised personnel in accordance with EN60204-1 and/or local regulations.
- Install a lockable circuit breaker to avoid inadvertent starting. Protect the motor and other electrical equipment from overloads with suitable equipment.
- The electric motors must be supplied



- with adequate cooling ventilation.
- Improper installation can cause fatal injuries.
- The MPE S 70 must not operate outside the application range.
- Make sure that the pressure is released from the MPE S 70 before the MPE S 70 is disconnected from any pipe connections.
- Before intervening in the MPE S 70/system, the power must be shut off and the starting device must be locked. When intervening in the MPE S 70 unit, follow the instructions for Service/Maintenance, chapter 8.
- A failure not to follow the instructions can result in personal injury and/or damage to the MPE S 70. It will also invalidate the warranty.
- The MPE S 70 must never run dry. Dry running produces heat and will cause damage to internal parts.
- If the MPE S 70 does not function satisfactorily, contact your local MPE S 70 distributor.



Use of this manual does not relieve operation and maintenance personnel of the responsibility of applying normal good judgment in the operation and care of this product.

3.2 Intended use

The MPE S 70 is designed for use as energy recovery device in Sea Water Reverse Osmosis (SWRO) or Brackish Water Reverse Osmosis (BWRO) system.

The MPE S 70 must not be used for other purposes than recommended and quoted for without consulting your local MPE S 70 distributor.

3.3 Application range

For application range see data sheet "MPE S 70 Pressure exchanger" available in appendix 11.1.

 Applications not suitable for the MPE S 70 can cause damages to the MPE S 70 unit, with risk of personal injury.

3.4 Preferred system design

Danfoss recommends building systems with a high degree of safety. Our preferred system design can be found in the data sheet "MPE S 70 Pressure exchanger" in appendix 11.1.

-  • It is always the system builders' responsibility to ensure that the system design does not cause any form of hazard and are adapted to local regulations.
- Proper installation and care of shutdown devices and over-pressure protection equipment is essential.

3.5 Initial start-up and settings of safety equipment

The system designer is responsible to design the equipment according to the local regulations where the equipment is running. According to PED 2014/68/EU a risk assessment must be made to identify and evaluate hazards which apply to his equipment on account of pressure.

Where under reasonable foreseeable conditions, the allowable limits could be exceeded, the pressure equipment must be fitted with, or provision made for fitting of a suitable protective device.

If positive displacement pumps are used be aware they can build up pressure exceeding the mechanical strength of the membrane vessels, pipes and other accessories. The pressure rise can be fast and may exceed the response time for electrical safety equipment, like pressure switch and control loop.

 To prevent such over-pressurisation, appropriate relief valves should be used or procedures should be implemented to safeguard the HP lines and instrumentations in the RO system.

3.6 Over-pressurisation caused by low pressure isolation

If both LP In and LP Out lines of the MPE70 is blocked and the MPE S 70 is exposed to high-pressure, there is a risk that the LP piping could be damaged by over-pressurisation.

 To prevent such over-pressurisation, appropriate relief valves should be installed in the LP side or procedures should be implemented to assure that the HP of the MPE S 70 is depressurised prior to the isolation of the LP side.

4. Arrival inspection, handling and storage

4.1 Arrival inspection

The MPE S 70 is packed in a wooden box. The MPE S 70 ports connector are protected by plastic caps that protect the MPE S 70 against dust and particles. Do not remove the caps before the system have been flushed and the MPE S 70 can be installed.

Remove all packing materials immediately after delivery. Immediately check the shipment for damage on arrival and make sure that the name plate/type designation is in accordance with the packing slip and your order.

In case of damage and/or missing parts, a report should be drawn up and presented to the carrier at once.

The identification label on the MPE S 70 states the specific type, the serial number and the code number of the MPE S 70; see fig. below.

The last three digits of the Serial No. indicate the week and year of production.



4.2 Return to the supplier

Flush the MPE S 70 with clean water. Drain the MPE S 70 and plug the port connections with a cap/cover.

Pack the MPE S 70 into a suitable container and make sure that it is suitably fastened to the container.

Please coordinate the shipment with your local authorized distributor or contact Danfoss direct to obtain a return shipping address.



4.3 Transport and Handling

- Personnel involved in lifting and transportation of the equipment must be trained in proper handling and safety procedures.
- Observe the local regulations regarding lifting.
- Use suitable, permitted lifting equipment.
- Be aware of individuals located in the operation area while lifting the component.

The weight of the MPE S 70 including electric motor can be found in the data sheet. All parts weighing more than 20 kg (44 lb) must be lifted using lifting slings and suitable lifting devices, e.g. an overhead crane or fork lift.

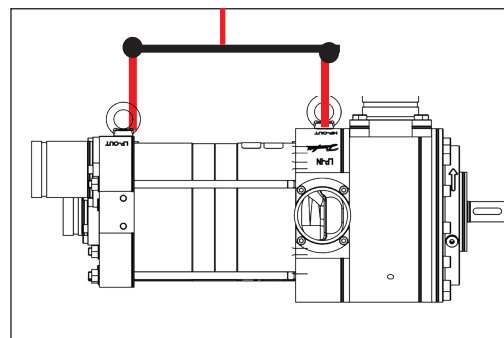
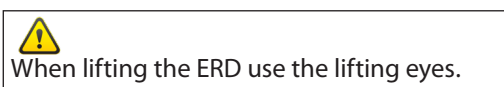
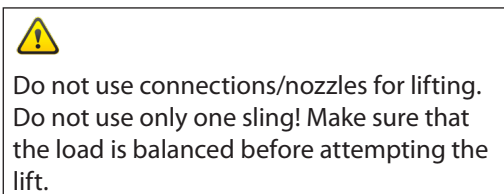

When the MPE S 70 is mounted with an electric motor and lifted horizontal *it must be lifted in the lifting eye on the MPE S 70.*

Some motors have specific lifting eyes - these should only be used for lifting the motor. For more information on lifting please read the installation guide MPE S 70 ERD Installation instruction.

Do not use connections/nozzles for lifting!

For more information see "MPE S 70 Installation instructions" in appendix 11.2.

Lifting the MPE S 70 with electric motor (vertical):

Lift the MPE S 70 unit with suitable lifting eyes mounted in the flange as shown on the picture. Suitable lifting eyes in part of the toolkit 180F4177.



Incorrect lifting can result in personal injury and/or damage of the unit.

4.4 Storage

Each MPE S 70 is tested in demineralized water before shipment. When tested the MPE S 70 is emptied and "plugged", this will prevent frost damages.

The storage temperature is is: -40 °C to +70 °C (-40°F to 158 °F) – provided that the MPE S 70 is drained of fluid and stored "plugged".

Frost protection is required if the MPE S 70 is not completely drained of fluids at temperatures below 1 °C

Storage of MPE S 70 that have been in operation:

For shorter periods of storage flush the MPE S 70 with permeate and store.

For long term storage (more than 2 months) Danfoss recommends to clean any biological growth of the surfaces. Store the Pressure Exchanger dry without water inside.

Danfoss recommends using DOWFROST from DOW Chemical Company or Chillsafe mono propylene glycol from Arco Chemical Company.

For further information on anti-freeze media, please contact Danfoss High Pressure Pumps.



- The MPE S 70 is delivered frost-protected from the factory.
- Only remove caps from the openings of the MPE S 70 at the time of installation.



4.5 Outdoor Storage

For outdoor storage cover the MPE S 70 (set) with waterproof material.

5. Technical data and design details

5.1 Design details

- 1: 3" Victaulic connections
- 2: Shaft
- 3: Low pressure shaft seal
- 4: Port flange
- 5: Valve plate
- 6: Cylinder barrel
- 7: Port plate (brine)
- 8: Port plate (feed)
- 9: Motor flange

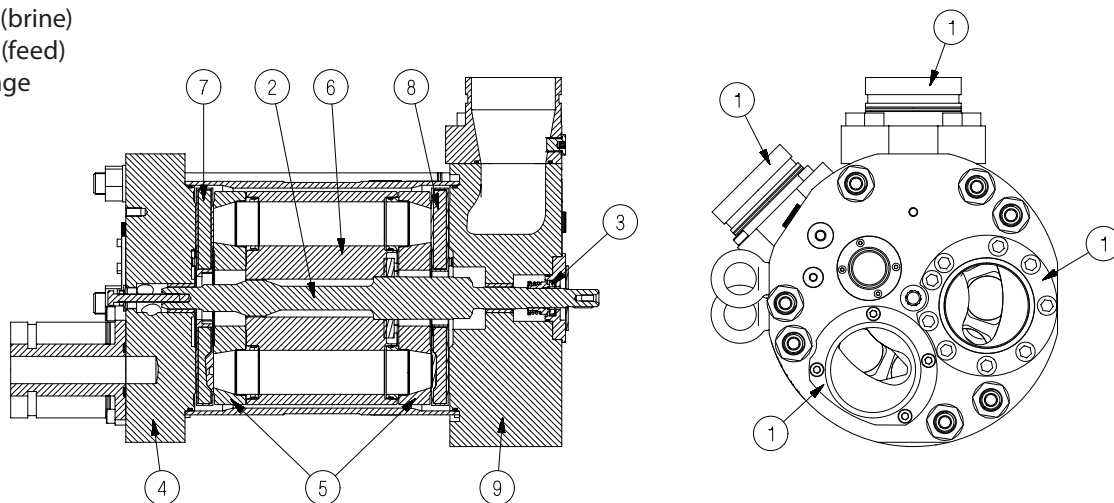

5.2 Sound level of the MPE S 70

The A-weighted sound pressure level @ 1m, $L_{PA, 1M}$ is for the MPE S 70 including the MPE S 70 motor.

Measurement are according to EN ISO 3744:2010. The test is made under following conditions:

1. MPE S 70 and electrical motor mounted together.
2. LP In pressure is 2 barg (29 psig)
3. Rotation speed is max. rpm
4. System pressure is max. allowable working pressure.

Influences

The structural noise may affect the noise level from the MPE S 70 system. The sound level is therefor only given for the MPE S 70 including the MPE S 70 motor. The Sound pressure level can be found in data sheet MPE S 70 Pressurre exchanger in appendix 11.1. Structural noise may affect the noise level.

Use multiple flexible Victaulic® couplings on the hard piping.

The noise level is influenced by:

- The speed of the MPE S 70. High speed creates more noise than low speed.
- Higher pressure provides higher sound level. For sound levels in specific duty point please contact Danfoss High pressure Pumps.

5.3 Materials

All critical parts of the MPE S 70 are made of super-duplex 1.4410/UN S32750/1.4462/ UN S32205/S31803 or the like.

Non-critical parts that are not in contact with sea water are made of AISI 316.

The shaft to the electrical motor is sealed by a standardised mechanical seal.

Depending on the NaCl concentration, the fluid temperature must be between: +2 °C to +50 °C (+35.6 °F to 122 °F).

5.5 Dimensions and weights

For dimensions and weights please refer to the MPE S 70 data sheet. See appendix 11.1.

5.4 Temperature and corrosion

The chart below illustrates the corrosive resistance of different types of stainless steel related to NaCl concentration and temperature.

5.6 Electrical motor data

See data sheet in appendix 11.1 and Operating and Maintenance instructions, electric motor in appendix 11.5.

 In order to minimise the risk of crevice corrosion, always flush the MPE S 70 according to the specified start/stop procedure.

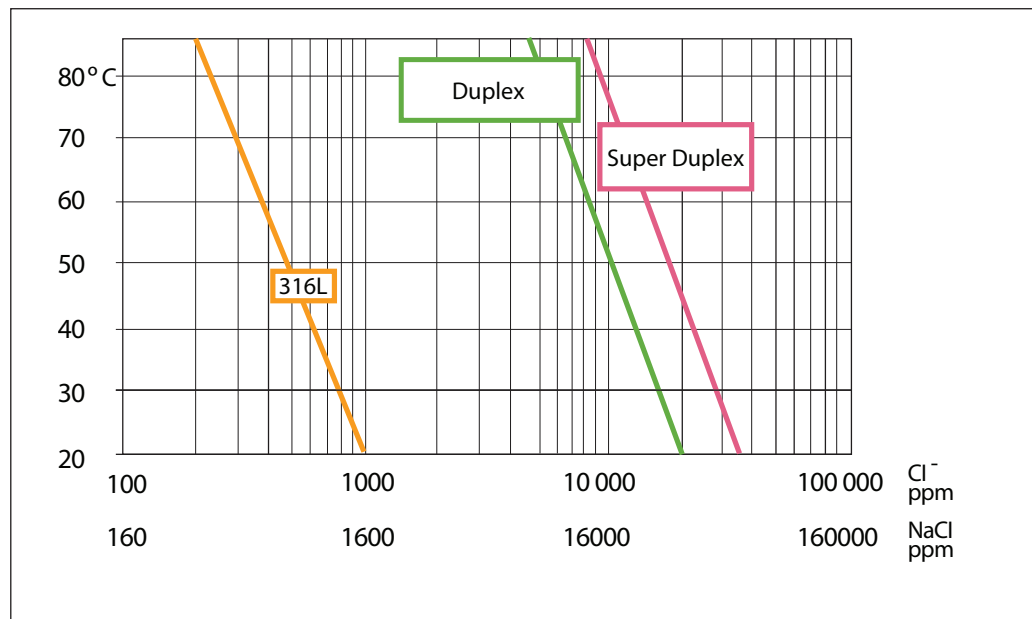

5.7 How does the MPE S 70 work?

The figure below shows the principle in the MPE S 70.

The MPE S 70 is a rotating isobaric pressure exchanger. The device is transferring the pressure in the Reverse osmosis brine reject stream to a seawater feed line stream that is reused in the RO system.

The sketch below shows how the energy is exchanged.

The MPE S 70 rotor is rotated by an electric motor. The rotor spins between two end covers.

Pressure energy is transferred directly from the high pressure stream to the low pressure stream in the ducts of the rotor. Some fluid that remains in the ducts serves as a barrier that inhibits mixing between the streams. The speed is controlled by the electric motor. The speed set-point is recommended to be proportional to the flow given by the booster pump. The flow and speed will be proportional. For further flow characteristic see data sheet section 5.1- MPE flow Curve.

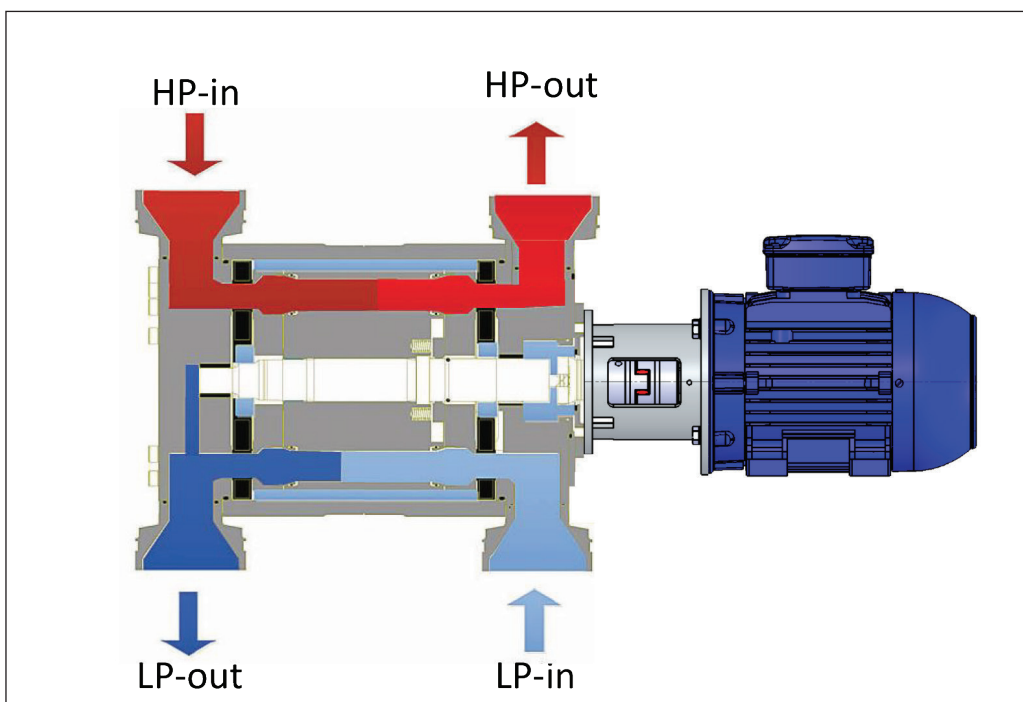

Sketch showing the principle of MPE pressure exchange

6. Operation and Controls

For the startup and shutdown of the MPE S 70 the following steps should be followed for safe operation. The Preferred P&ID and control loops will be used in the explanations below.

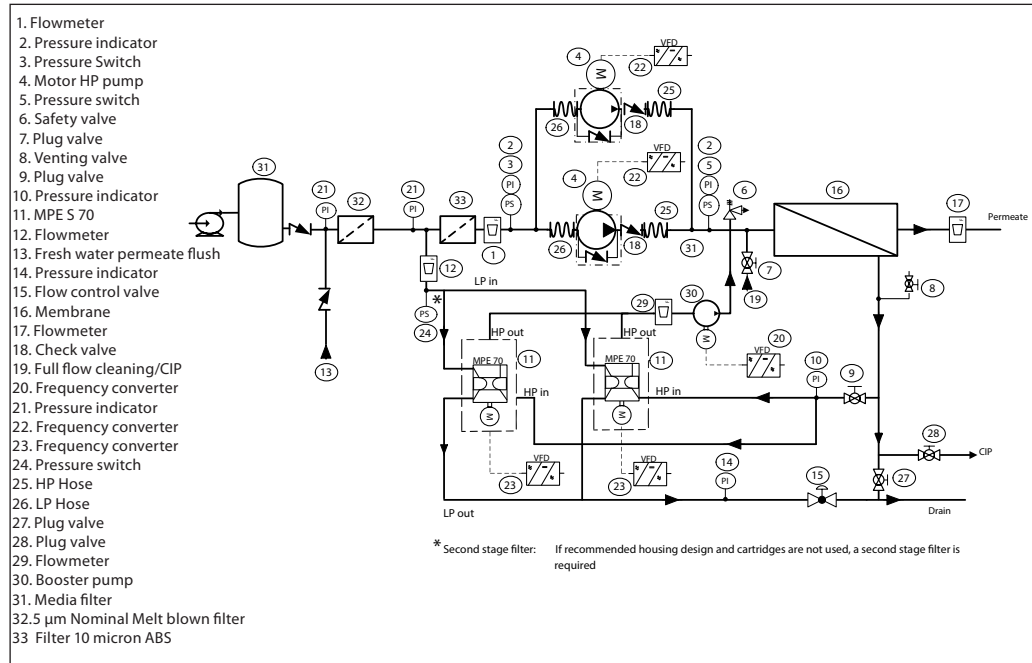

Preferred P&ID

Loop N°	Control reference	Position number	Control element	Position number	Set points
1	Pressure transmitter	21	Seawater intake pumps	-	2 barg (29 psig)
2	Low pressure inlet flow	12	Control valve	15	Design flow
3	Booster pump flow	29	Booster pump	30	Design flow
4	Booster pump flow	29	MPE S 70	11	Design flow
5	Fresh water permeate flush	12	Control valve	15	Design flow for flushing
6	MPE S 70 flushing	12	Seawater intake pumps		Design flow
7	MPE S 70 flushing	29	Booster pump & MPE S 70	30 & 11	Design flow
8	MPE S 70 flushing	12	Control valve	15	Design flow

Control loops

6.1 Initial start-up and flushing

It is recommended to disconnect all connections to the MPE S 70 and to thoroughly flush the piping before the MPE S 70 is connected to the inlet and outlet connections. Prior to the initial start-up, all piping associated with the MPE S 70 unit should be thoroughly flushed to assure that no impurities enter the MPE S 70. Inadequate pre-flushing will strongly affect the life of the MPE S 70 and may lead to its eventual breakdown.

It is essential that the water used for the final pre-flush is pre-filtered to a level described in chapter 6.8.

Strainers do not eliminate the need for thoroughly pipe flushing before commissioning.

For more information on the importance of proper filtration, please consult our publication data sheet, "Filter solutions for high-pressure pumps and ERDs", which also will provide you with an explanation of filtration definitions and guidance on how to select the right filter.

6.2 Air bubbles

Large bubbles in a pressurised RO system can result in damage to piping and equipment. All air must be bled from both the LP and HP before the RO system is pressurised. Special consideration should also be given to air bubbles in feed flow, continuously fed into the HP pump and MPE S 70 could cause increased wear.

6.3 Start-up sequence

Following the start sequence of the seawater intake pumps water must be flushed through valves and/or brine outlet valves to ensure constant water flow with no air or particles entering the RO system.

Booster pumps will be started first followed by the MPE S 70 and then the high pressure pumps (always in that order).

The control valve Pos 15 will open slowly. Control loop no. 2 is activated to reach the setpoint value of the design flow. The flow will be read in flowmeter (12). During this the system bleed valves can remain open. The Booster pumps is started by the control loop no. 3. Once all return flows from Booster pumps have been stabilized and all the air have been removed, the bleed valves can be closed and the MPE S 70 will be started through control loop no. 4. During this the the system bleed valves remain open until system have been bled.

When the bleed valves have been closed the high Pressure pump can be started and the recovery rate can be confirmed by the flowmeters as described:

The recovery rate can be calculated by the permeate flowmeter Pos 17 and the flow going into the Membrane. The flow to the membranes can be calculated from the two flowmeters pos 1 and pos 29.

Recovery Rate = (17) / (1+29)

6.4 Shut-down sequence

When the high-pressure pump is shut down the shutdown sequence starts. When the high-pressure pump flow measured at flowmeter (1), is lower than a designed flow value. The Booster pump can be shut down once the osmotic pressure have been reached. The MPE S 70 will shutdown after the booster pump.

After the Booster pump and the MPE S 70 have been shut down the seawater intake pumps can be turned off.

6.5 High pressure remains after shutdown

The HP line of the RO system can remain pressurised for a long time after shutdown. If more rapid system depressurisation is required, the system should be bled through a suitable valve.



Always check the pressure in the high-pressure lines before making service in the HP lines or pressurised equipment.

6.6 CIP or membrane cleaning

During CIP cleaning the flush water coming out of the membranes may consist of a large amount of suspended inorganic particles. It is important to assure that these particles must not enter the MPE S 70. After CIP Cleaning the system should be flushed.

6.7 Flushing

RO membranes require periodic flushing to limit biological fouling.

There are two types of flushing: feed water (Seawater) flush and fresh water (Permeate) flush.

Regardless of the flush water used, the water must be pre-filtered to the level described in chapter 6.8. All parts of the MPE S 70 must be flushed, i.e. LP- and HP flow channels.

It is required to flush with permeate:

- After chemical treatment
- For stops lasting more than 1 day the MPE S 70 must be rotated during permeate flush
- Before long time shut down

It is required to flush with fresh sea water prior to every shut down, to remove brine in the MPE70.

NB!
Operating at low pressure should be limited. Operating at low pressure causes cavitation but is not critical, it is not recommended to operate at this state for longer than 30 min.

Failing to flush the MPE S 70 with fresh water before extended shutdowns may result in extensive biological growth and cause corrosion in the MPE S 70 and other equipment in the RO system.

6.8 Seawater quality

6.8.1 Pre-filtration

It is important that the incoming water is filtered according to the specification given in the data sheet appendix 11.1 to assure optimum service life. A true graded density melt-blown depth filter cartridge is recommended. Poor pre-filtration of the feed water will result in reduced service life of the MPE S 70.

The MPE S 70 may request a different pre-filter of the seawater than the HP pump and other components in the RO system.

It is important to use a proper filter housing that allows a good seal between housing and filter cartridge. If there is a high risk of water by-pass it is recommended to use a second stage filter solution.

As the various filters on the market differ greatly, Danfoss High Pressure Pumps recommends using cartridges with consistent, reliable performance and high efficiency, in which fibres are blown continuously onto a central support core.

Danfoss High Pressure Pumps does not recommend cartridges requiring any type of binders or resins.

For more information on the importance of proper filtration, please consult our data sheet "Filter solutions for high-pressure pumps and ERDs", which also will provide you with an explanation of filtration definitions and guidance on how to select the right filter.

6.8.2 Chemicals

The MPE S 70 can be flushed with biocide like the membranes. The biocide must be compatible with the materials used in the MPE S 70. MPE S 70 material can be found in the parts list, appendix 11.4.

7. On-site installation

7.1 Design details

For safety instruction see chapter 3.

7.2 Assembly MPE S 70 to electric motor

The MPE S 70 is mounted to the electric motor via a bell housing. Its is important to follow the installation instruction given in the Installation guide “MPE S 70 Installation instructions” in appendix 11.2. If alternative mounting is desired, please contact Danfoss High Pressure Pumps

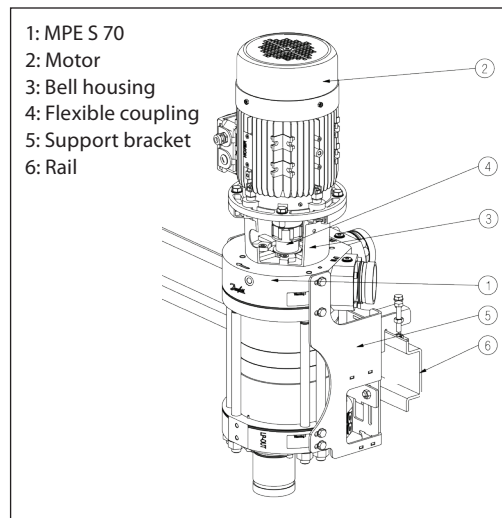

The figure above illustrates the major MPE S 70 components.

7.3 Danfoss offers rail and bracket solution

Danfoss offers rail and bracket solution for vertical installation. The rail should be mounted on a steel frame. The base frame itself must be aligned to avoid bending caused by bolting to an uneven foundation. time.

See installation guide for further info.

An unlocked bolt can result in personal injury and/or damage to the MPE S 70

Misalignment between MPE and Manifold design may cause stress and/or damage to the victaulic connection. See guideline “pipe connection” 180R9367

7.4 Orientation

The MPE S 70 must be mounted vertically.

When mounted vertically, the electric motor must be placed above the MPE S 70.

7.5 Piping and joints

Hard piping to the MPE S 70 must be properly aligned to avoid stress on the MPE S 70 port connections. Don't use the MPE S 70 as a strain for hard piping.

7.6 Accessibility

With respect to the service and replacement of the complete MPE S 70 unit, it is recommended to maintain sufficient space around the unit.

The space must be sufficient enough to allow for safe lifting of the equipment, with no risk for personal injury and/or damage to the MPE S 70. For more information about lifting please see the installation guide “MPE S 70 Installation instructions” in appendix 11.2.

7.7 Motor and frequency converter

7.7.1 Electric motor

The MPE S 70 must only be driven by an electric motor.

 Using anything other than an electric motor can lead to an irreparable fracture of the MPE S 70's internal parts.

The rotation speed on the electric motor must be controlled by a VFD. The direction of rotation can be seen on the identification label.

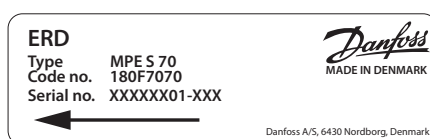

When connecting to the power supply, check the direction of rotation. The rotation can only be checked with water connected and the transit screw removed.

This can be made by either:

1. Looking at the fan in the end of the electric motor.
2. Removing the plug in the bell housing and watch the rotation of coupling.
3. Before assembling the MPE S 70 on the electric motor, check the rotation of the shaft.

 Special attention has to be on NON PROTECTED - FREE ROTATING shaft on the electric motor. Ignorance will or could result in personal injury.

 Running the MPE S 70 in the wrong direction for more than a few minutes can cause un-intended wear on the MPE S 70.
If the electric motor is running at a lower speed, extra care must be taken to ensure that the electric motor is NOT overheated. External cooling may be necessary.

7.7.2 Starting torque for the MPE S 70

Because of the inertia and stick-slip friction of the MPE S 70 internal parts, the motor must be able to provide the specified torque. Once the MPE S 70 is turning the torque will drop to the operating torque specified for the MPE S 70.

7.7.3 Frequency converter

The frequency converter Must be able to operate at constant torque over the whole range of speeds. A special attention should be taken when dimensioning the Frequency drive for the MPE S 70. The drive must be able to provide start current enough for the motor to start. The start current can be found in the data sheet see appendix 11.1.

If more electric motors are powered by the same VFD, each electric motor must be equipped with "torque limit equipment" to protect the MPE S 70 against overload.

 The electric motor must always be protected against overload.

8. Commissioning, start-up and shutdown

8.1 Safety regulations

The MPE S 70 has a transit screw installed that must be removed before startup. Instructions on this can be found in the installation guide - Appendix 11.2.

 The operator ensures that all inspection and installation work is performed by authorised, qualified specialized personnel who are thoroughly familiar with the manual.

 • Before starting up the MPE S 70 and the high-pressure pump, make sure that the following requirements are met:

- The MPE S 70 has been properly connected to the electric power supply and is quipped with all protection devices in accordance with EN 60204-1
- Check that all motor protections are properly set.
- All safety equipment, auxiliary equipment and connection required are properly connected and operational.
- Check all bolts in all connections and in the foundation of the MPE S 70.

8.2 Support

Danfoss A/S offers commissioning and service at system manufacturer's location. Rated quotes are offered upon request.

8.3 Commissioning

Before starting up the MPE S 70 and the high-pressure pump, make sure the following requirements are met:

 • All pipes are flushed, free from debris and full of water.

 • The MPE S 70 has been bled and is full of water.

- At pressure lower than 10 barg, check the system for leakage.

 Slowly raise the pressure in the system and set all pressure switches to the correct limit and continually check all connections.

 • If pressure relief valve is present, set pressure relief valve on both low and high-pressure at the maximum system pressure.

- Check high-pressure piping for proper assembly and inspect for external leakage for all connections. If there is no pressure relief valve installed make sure the brine concentrate valve is open to allow pressure relief during commissioning.

9. Service/Maintenance

9.1 Safety regulations

 The operator ensures that all maintenance, inspection and installation work is performed by authorised, qualified specialist personnel who are thoroughly familiar with the manual.

 Before intervening in the MPE S 70/ system:

- The power must be shut off and the main switch must be locked.
- The pressure in the high-pressure lines must be drained to the low-pressure side.
- The water in all connected pipes must be drained.

 Always use suitable safety and lifting equipment when handling the MPE S 70, and follow the instructions in chapter 4.3.

 • Assure correct settings of safety equipment before start-up.

- When the system is re-started after service and maintenance follow the instruction in chapter 8.



9.2 Support

Danfoss A/S offers commissioning and service at the system manufacturer's location. Rates/quotes are offered upon request.



9.3 Maintenance schedule

The schedule of preventive maintenance below will help ensure that the MPE S 70 provides years of trouble-free performance.



One day after commissioning:

-  1. Re-check bolts in the foundation and the base plate of the MPE S 70 and tighten the bolts to specified torque if necessary.
-  2. Visually inspect all pipe connections/couplings for external leakage.
3. Re-check bolts in all pipe connections/couplings and tighten the bolts to specified torque if necessary.
4. Note the operating current of each individual MPE S 70.

Three months after commissioning:

-  1. Re-check bolts in the foundation and the base plate of the MPE S 70 and tighten the bolts to specified torque if necessary.
2. Re-check alignment of the MPE S 70 base plate and MPE S 70.
3. Visually inspect all pipe connections/couplings for external leakage.
4. Re-check bolts in all pipe connections/couplings and tighten the bolts to specified torque if necessary.
-  5. Note and compare the operating current at the VFD. If there is any irregular results inspect varying more than 25% we recommend to inspect the internal parts.

Annually:

-  1. Re-check bolts in the foundation and the baseplate of the MPE S 70 and tighten the bolts to specified torque if necessary.
2. Re-check alignment of MPE S 70 base plate and MPE S 70.
-  3. Visually inspect all pipe connections/couplings for external leakage.
4. Re-check bolts in all pipe connections/couplings and tighten the bolts to specified torque if necessary.
5. Note and compare the operating current at the VFD. If there is any irregular results inspect varying more than 25% we recommend to inspect the internal parts.

9.4 Recommended service intervals for MPE S 70

The water quality is impacting the wear and should therefore be taken into account. For more information please contact Danfoss High Pressure Pumps.

See below table.

For detailed information see parts list for MPE S 70 in appendix 11.4.

9.5 Recommended service for electric motor

Danfoss recommends to use the manufacturer's recommendations for electric motor service and maintenance, see appendix 11.5.

10. Trouble-shooting

10.1 Safety regulations

 The operator ensures that all inspection and installation work is performed by authorised, qualified specialist personnel who are thoroughly familiar with the manual.

 Before intervening in the MPE S 70/ system:

- The power must be shut off and the starting device be locked.
- The pressure in the high-pressure lines must be drained to low-pressure side.
- The water in all connected pipes must be drained.

The numbers in () correspond to the preferred system design and P&ID (see data sheet)

Problem	Possible cause	Action
VFD cannot start the MPE S 70 at initial start-up	VFD is not designed for constant torque.	Choose a VFD that is designed for constant torque
	VFD cannot deliver sufficient start torque/current	Choose a VFD that is designed for sufficient start torque.
	Ramp-up settings in the VFD are not correct. VFD is tilting	Set ramp-up parameters correct.
Torque on MPE S 70 is too high during operation		
	Debris in the MPE S 70	Clean the system
	Wear in the MPE S 70	Repair or change the parts
Permeate production is too low (17)	Valves (6), (7), (8) or (16) are leaking	Repair or change valve(s)
	Internal leakage in MPE S 70	If the HP pump is working OK identify which MPE S 70 is causing the leak by measuring the housing pressure of each individual MPE S 70
		Check the HP pump and repair if necessary
Pressure on the membranes (5) is too high	Fouling on the membranes	Clean the membranes
	Mixing in the MPE S 70 is too high	Check flow on LP-in (12) adjust it with the flow in pos. (29)
	Flow out of the MPE S 70 is too low and causes a recovery rate that is too high	Check the flowmeter pos (29) and adjust booster pump pos (30) accordingly
Pressure on the membranes (5) is too low	Valves (6), (7), (8) or (16) are leaking	Repair or change valve (s)
	Internal leakage in MPE S 70	Repair MPE S 70
		Check the HP pump and repair, if necessary

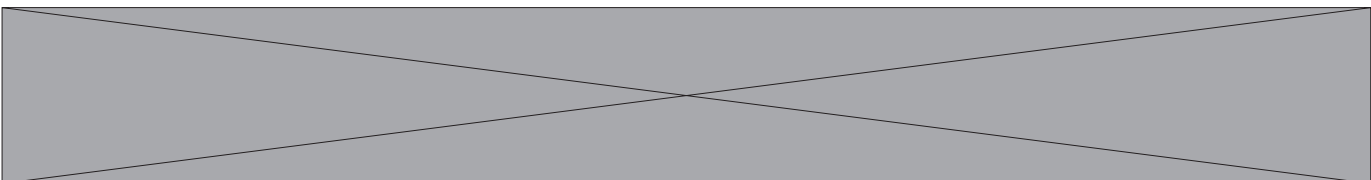

ENGINEERING
TOMORROW

Danfoss

Operating guide

Energy Recovery Device

MPE S 70

Installation, Operation and Maintenance Manual



10. Appendices

11 Appendices	23
11.1 Data sheet MPE S 70 (AI551439122001en-000101)	25
11.2 Instruction (AN367027298445en-000202)	39
11.3 Design guide Pipe connections (180R9367)	51
11.4 MPE S 70 part list (AX367028596447en-000304)	53
11.5 Operating- and maintenance instruction, electric motor (180R9230)	59

ENGINEERING
TOMORROW

Danfoss

Data sheet

Energy Recovery Device

MPE S 70



Table of Contents

Contents	
1.	General information.....3
2.	Benefits.....3
3.	Applications.....3
4.	Technical data.....4
4.1	MPE S 70 with and without motor.....4
5.	Performance curves.....6
5.1	MPE flow curves.....6
5.2	Mixing curve.....7
6.	Temperature and corrosion.....8
6.1	Operation.....8
7.	Installation.....8
7.1	Operation and mounting.....8
7.2	Mounting MPE to motor.....9
7.3	Connection to system.....9
7.4	Design Configuration for Manifolds.....9
7.5	Filtration.....9
7.6	Noise.....9
7.7	RO systems with an MPE S 70.....10
8.	Dimensions and connections.....12
8.1	MPE S 70 without electric motor.....12
8.2	MPE S 70 with IE3 motor 2.2 kW on base frame vertical - front mounted.....13
9.	Accessories.....14

1. General information

Energy Recovery Devices (ERD) are used in reverse osmosis (RO) systems to recycle the energy held in discharged brine from the membranes. MPE S 70 is designed for use with low viscosity and corrosive fluid such as sea water.

control combined with the high efficiency from the isobaric pressure exchanger.

The MPE S 70 design ensures lubrication of all moving parts by the fluid itself.

The Danfoss MPE S 70 consists of an isobaric pressure exchanger driven by an electrical motor. It offers unique benefits from the electrical

All parts included in the MPE S 70 are designed to provide long service life with a constant high efficiency and minimum service required.

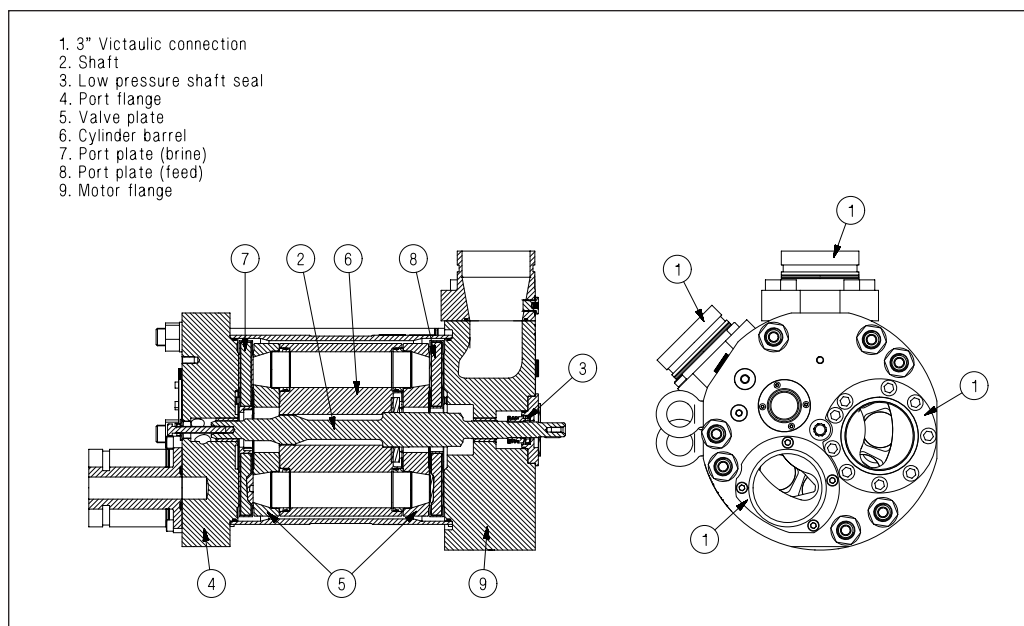

2. Benefits

Significant power savings and low specific energy consumption (SEC)
 Simple operation with design that prevents overspin
 Full control of pressure exchanger through VFD control
 Long and predictive service intervals

Corrosion resistance (all wetted parts are made of high corrosion-resistant materials e.g. Super Duplex or Hastelloy)
 Build to operate continually at full capacity

3. Applications

Danfoss ERDs are built into a broad range of RO desalination plant around the world. Typical applications for MPE S 70 will be:

Municipal and private waterworks

4. Technical data

4.1 MPE S 70 with and without motor

MPE S 70		MPE S 70	MPE S 70 with IEC motor
Code number		180F7171	180F7066
Pressure			
Min. pressure HP out (min. allowable working pressure)	barg	40	40
	psig	580	580
Max. pressure HP out (Max. allowable working pressure, MAWP) ¹⁾	barg	83	83
	psig	1200	1200
Min. pressure on HP in, intermittent ^{2) 3)}	barg	2	2
	psig	29	29
Max. diff. pressure HP in, - HP out	barg	0.66	0.66
	psig	9.6	9.6
Max. pressure LP in (MAWP) ¹⁾	barg	5	5
	psig	72	72
Max. pressure LP in, peak	barg	10	10
	psig	145	145
Min. allowable working pressure LP in	barg	2	2
	psig	29	29
Max. differential pressure (LP in - LP out)	barg	0.74	0.74
	psig	10,73	10.73
Max. static test pressure (HP in and HP out)	barg	108	108
	psig	1566	1566
Max. static test pressure (LP in and LP out)	barg	13	13
	psig	189	189
Speed			
Min. speed	rpm	625	625
Max. speed	rpm	875	875
Flow rates			
Flow at min. speed, HP out	m ³ /h	50	50
	gpm	220	220
Flow at max. speed, HP out	m ³ /h	70	70
	gpm	308	308
Typical lubrication flow at 60 barg (871 psig)	l/min	16	16
	gpm	4.2	4.2
Peak flow, LP in ⁴⁾	m ³ /h	105	105
	gpm	462	462
Max. allowable working flow, LP in ⁵⁾	m ³ /h	70	70
	gpm	308	308
Efficiency			
Total efficiency ⁶⁾	%	96	96
Technical specifications			
Media temperature ⁷⁾	°C	2-40	2-40
	°F	36-104	36-104
Ambient temperature	°C	0-50	0-50
	°F	32-122	32-122
Filtration requirements (nominal) ⁸⁾	5 µm melt blown		
Salinity increase at membrane at 40% recovery rate at balanced flow ⁹⁾		2 - 3%	2 - 3%

Technical specifications		MPE S 70	MPE S 70 with IEC motor
Weight (dry)	kg	114	151
	lb	251	333
Weight (operation with water)	kg	119	156
	lb	262	344
Noise			
Sound pressure level L_{PA} 1 m ¹⁰⁾	dB(A)	85	85
Footprint			
Footprint (vertical position) ¹¹⁾			0.175
			1.9
Torque data			
Max. allowable working torque	Nm	15	15
	lbf-ft	11	11
Max. starting torque (stick/slip)	Nm	90	90
	lbf-ft	66	66
Motor data			
Nominal speed	rpm		970
Rated current at 400V	A		5.7
Motor size	kW		2.2 ¹²⁾
Frame size	IEC		112
	Poles		6
Rated motor torque at nominal speed	Nm		21.8
	lbf-ft		16.07
Rated motor ambient temperature ¹²⁾	°C		40
	°F		104
Motor insulation	Class		F/B
Motor degrees of protection	IP		55
Motor efficiency	%		84.3
Painting RAL9005			C3L
Variable Frequency Drive (VFD) data ¹³⁾			
Must be able to operate at constant torque over the whole range of speeds. Must be able to deliver start current of 23.5 A. For a Danfoss FC 51 micro drive a 7.5 kW drive is required to deliver this current. If other drives are used make sure it can provide the start current required.			

- ¹⁾ Max. allowable working pressure of continuous operation. For lower and higher pressure, please contact Danfoss.
- ²⁾ Typical pressure level at start-up and permeate flush.
- ³⁾ Intermittent pressure is acceptable for less than 10 minutes within a period of 6 hours.
- ⁴⁾ At system start-up: MPE S 70 can run for up to 10min. with 150% of max. rated flow at LP inlet. The time where max. rated flow is exceeded should be kept as short as possible to minimize wear.
- ⁵⁾ Continuous operation: MPE S 70 can operate continuously with up to 10% over flush with the limitation that the flow rate at LP inlet shall not exceed 70 m³/h.
- ⁶⁾ Efficiency measured at 70 m³/h, balanced flow, 60 bar(g) on HP out. Power consumption of Motor and Variable Frequency Drive included.
- ⁷⁾ Dependent on NaCl concentration.
- ⁸⁾ Please see section 7.5 filtration.
- ⁹⁾ Balanced flow: The mixing rate is defined at balanced flow when HP-out is equal to LP-in.
- ¹⁰⁾ MPE S 70 sound pressure level at 60 barg and max. flow.
- ¹¹⁾ Area recommended with IE3 motor configurations (excl. of space to service MPE)
- ¹²⁾ For higher temperature contact Danfoss
- ¹³⁾ A special attention must be taken when selecting the frequency drive. See Variable Frequency Data comments in the table above.

5. Performance curves

5.1 MPE flow curves

The diagram below shows the minimum speed needed for the required flow.

For detailed overview please use the MPE selection tool.

The MPE S 70 is delivered with a 3.1 performance certificate according to EN10204.

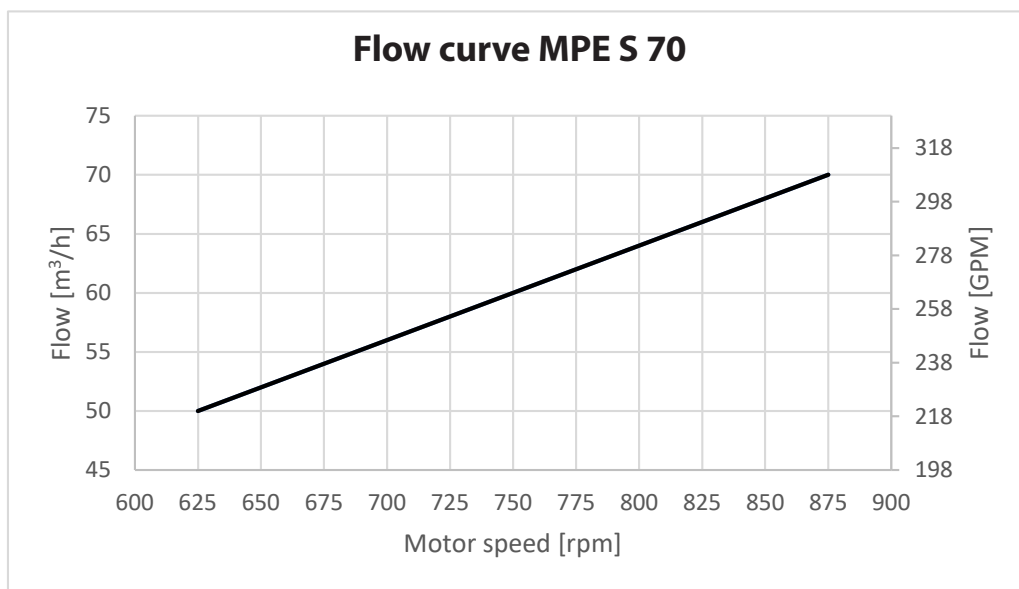

5.2 Mixing curve

The curve below shows the mixing during operation. Flush rate of 0 is when LP-in flow equals HP-out (Balanced flow).

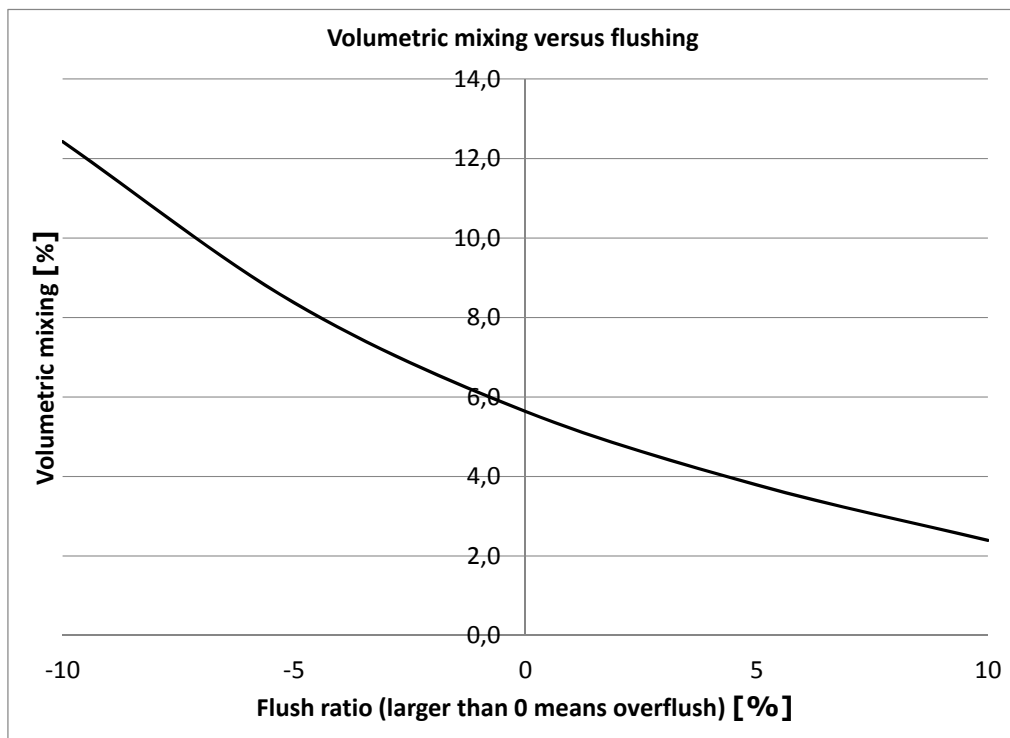

6. Temperature and corrosion

6.1 Operation

The chart below illustrates the corrosive resistance of different types of stainless steel related to NaCl concentration and temperature. All critical parts of the MPE S 70 is made of Super Duplex 1.4410/UNS 32 750 or Hastelloy C276

Always flush the MPE S 70 with fresh water at operation stop in order to minimize the risk of crevice corrosion.

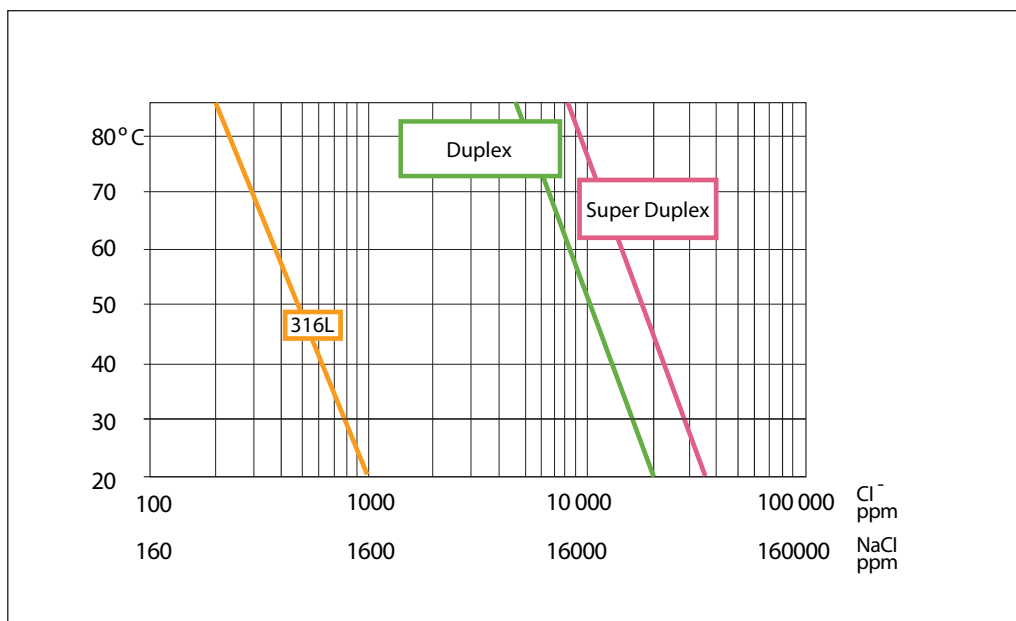

7. Installation

7.1 Operation and mounting

The MPE S 70 is build for vertical installation. The MPE S 70 is connected to the electric motor by a bell housing. The bell housing keeps the motor and bell housing perfectly aligned.

To install the MPE and motor to a frame Danfoss have created a bracket and rail system that makes the installation easy and flexible. The alignment between the manifolds and MPE S 70 is easily done via the adjustable bracket that keeps the MPE S 70 in place.

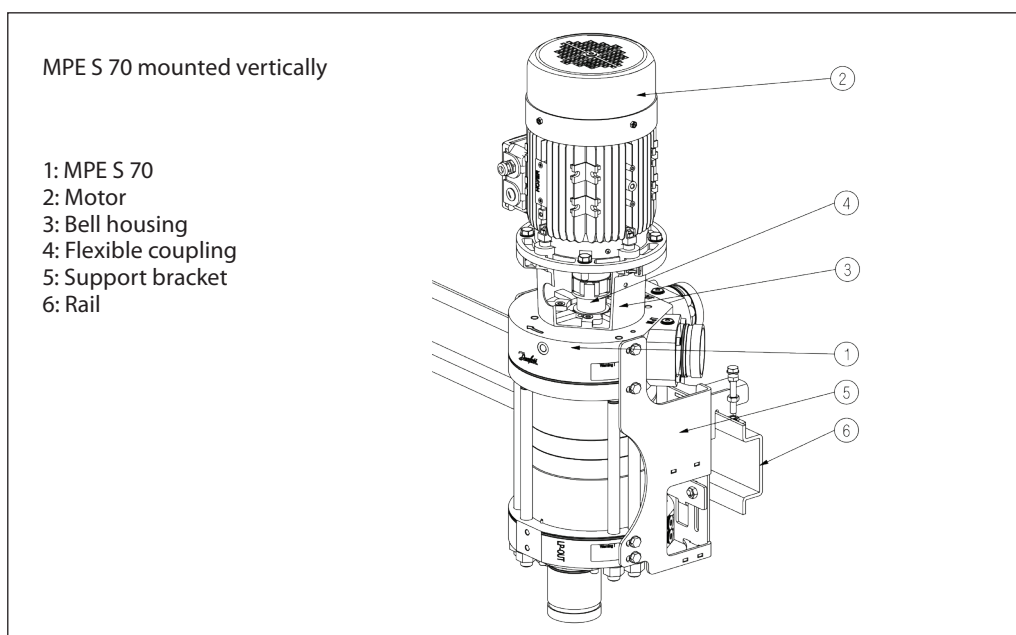

7.2 Mounting MPE to motor

The MPE is attached to the electric motor by a bellhousing. The bellhousing centers the shafts of motor and MPE and additionally serve as coupling protection. The shafts are connected through a flexible jaw coupling.

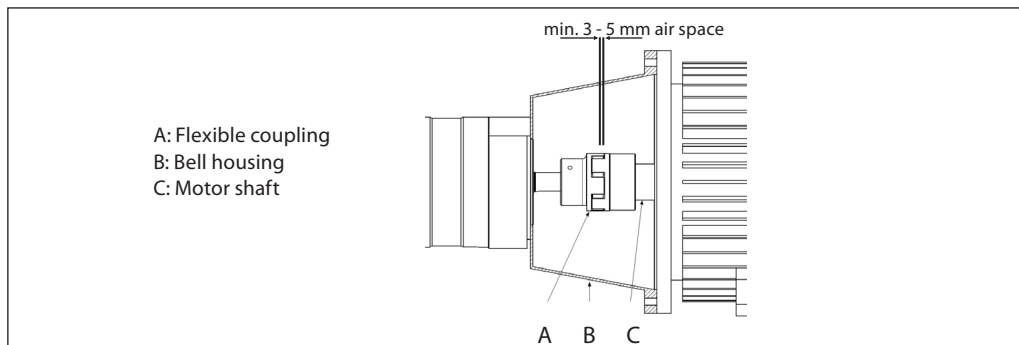

7.3 Connection to system

The MPE connection ports are designed for hard piping. Danfoss recommends to follow the Guideline 180R9367 - Pipe connection.

7.4 Design Configuration for Manifolds

When setting up MPE S 70 in parallel Danfoss recommends U flow for manifold designs and a maximum flow velocity of 3,8 m/s.

The MPE S 70 speed is not affected by the flow but it is preferred to have a even flow distribution among the MPE S 70 units and investigations done by Danfoss shows that Z-Flow requires a lower flow velocity to get an even distribution. If for some reason Z flow is selected Danfoss recommends to reduce the flow velocity to 2 m/s

Below sketch shows the concept of U-Flow design and Z flow design

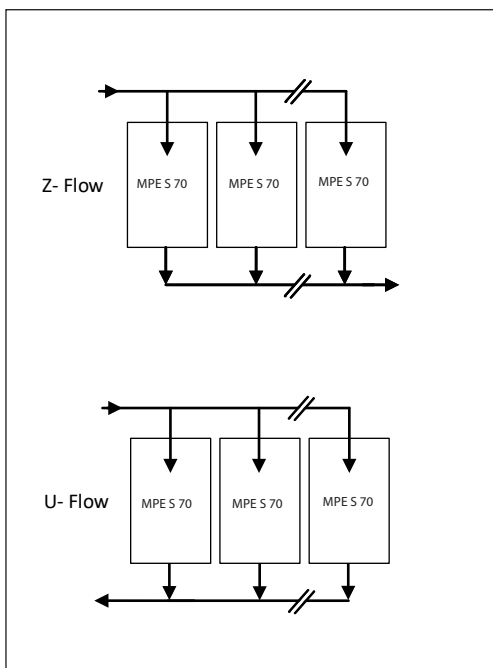

7.5 Filtration

High quality water extends the service life of the whole system.

Water to the MPE S 70 must be filtered to 5 µm nominal, using melt-blown depth filter with a proven efficiency of min. 85%. Consult Danfoss for correct choice of filter.

It is important when selecting the filter and filter housing to ensure good cartridge end sealings.

As the various filters on the market differ greatly, Danfoss High Pressure Pumps recommends using cartridges with consistent, reliable performance and high efficiency and where fibres are blown continuously onto a central support core. Danfoss High-pressure pumps does not recommend cartridges requiring any type of binders or resins.

7.6 Noise

Since the MPE is mounted on a bell housing and electric motor, the noise level should be determined for a complete system.

It is recommended to use multiple Victaulic clamps to avoid structural noise.

The noise level is influenced by:

Speed:

- High rpm makes more fluid/structure-borne pulsations/vibrations than low rpm due to higher frequency.

Pressure:

- High pressure makes more noise than low pressure.

Connections to MPE:

- Variable frequency drives (VFD): Motors regulated by VFDs can increase noise level if the VFD does not have the right settings.

7.7 RO systems with an MPE S 70

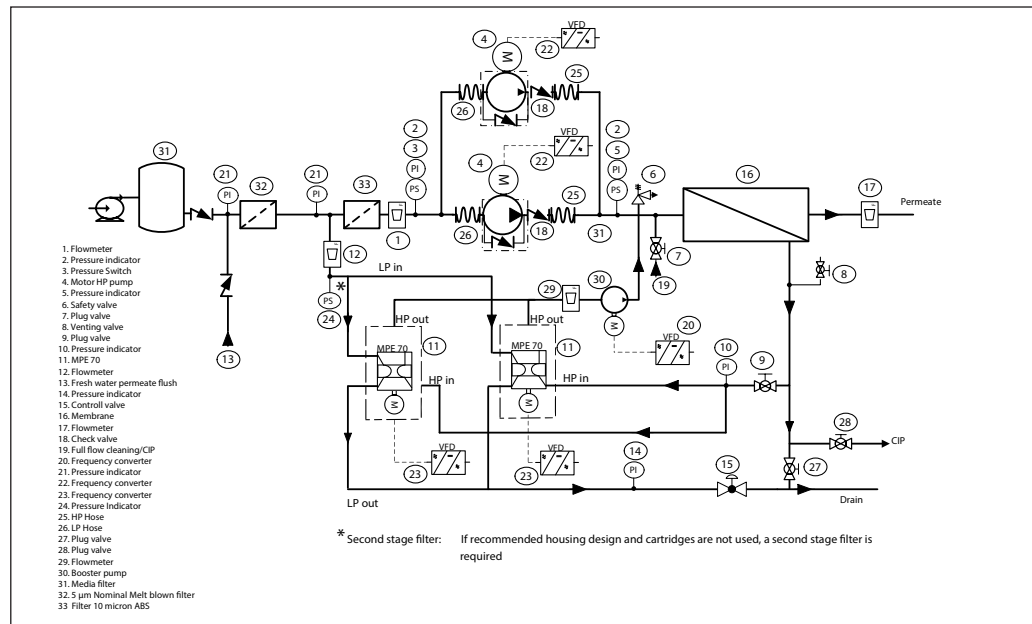

Explanation of P&ID setup

A. **Inlet filter:**

Place inlet filters (32) on LP string in front of the MPE S 70 (11). Please see Guide line (AI317041322125en-000101) on Filtration. Thoroughly clean pipes and flush system prior to start-up.

B. **Inlet pressure:**

The max. and min. inlet pressure must be controlled according to specifications in datasheet for MPE S 70.

C. **Piping:**

Dimension the piping to obtain minimum pressure loss (large flow, minimum pipe length, minimum number of bends/connections and fittings to prevent pressure loss and flow turbulence).

D. **Inlet flow control and mixing:**

To balance LP flow up against HP flow on the MPE S 70 and control mixing, place flowmeters on low-pressure inlet (12) of the MPE S 70 and on highpressure output (29).

E. **HP flow control:**

To adjust the recovery rate and the HP flow of the MPE S 70. Regulate the speed of the booster pump (30). Adjust the speed of the MPE S 70 if needed.

F. **Low pressure flow control:**

In order to control the low pressure flow, a flow control valve (15) must be installed in the common low pressure outlet pipe from the MPE S 70s. The valve should be designed to control flow.
It is recommended to use a manual valve with lock function or an automatic controlled valve.

G. **Variable speed and overload protection:**

Install a VFD to control the speed of the MPE S 70. The speed is defined by HP flow given by the flowmeter (29).

H. **Membrane cleaning**

Valves pos. 9, 27 and 28 are used for bypassing the MPE S 70 when CIP cleaning.

I. **Air venting:**

Install an air bleed valve (8) at the highest point of the high-pressure piping to ensure the air is purged from the system before startup.

J. **Pressure relief (high pressure):**

The pressure relief valve (6) protects the HP streams in the system against pressure overload and relieves the water if the pressure exceeds the maximum set pressure. If the high-pressure pump is a positive displacement pump, the pump can built up a very high pressure that will exceed mechanical strength of the membrane housing, pipes and other accessories. When using Danfoss APP pumps with Danfoss VCM check valves, it is recommended to place a pressure relief valve or pressure safety valve as illustrated. In case the Danfoss check valves are not used, the valve must be placed between pump and check valve (See 180R9371, Design Guide Pressure safety valve in seawater RO system for more details).

For a more elaborate description of the P&ID setup, please consult the Danfoss Design Guide Piping & Instrumentation Diagram (P&ID) (AJ362145037077en-000101) or contact Danfoss.

8. Dimensions and connections

8.1 MPE S 70 without electric motor

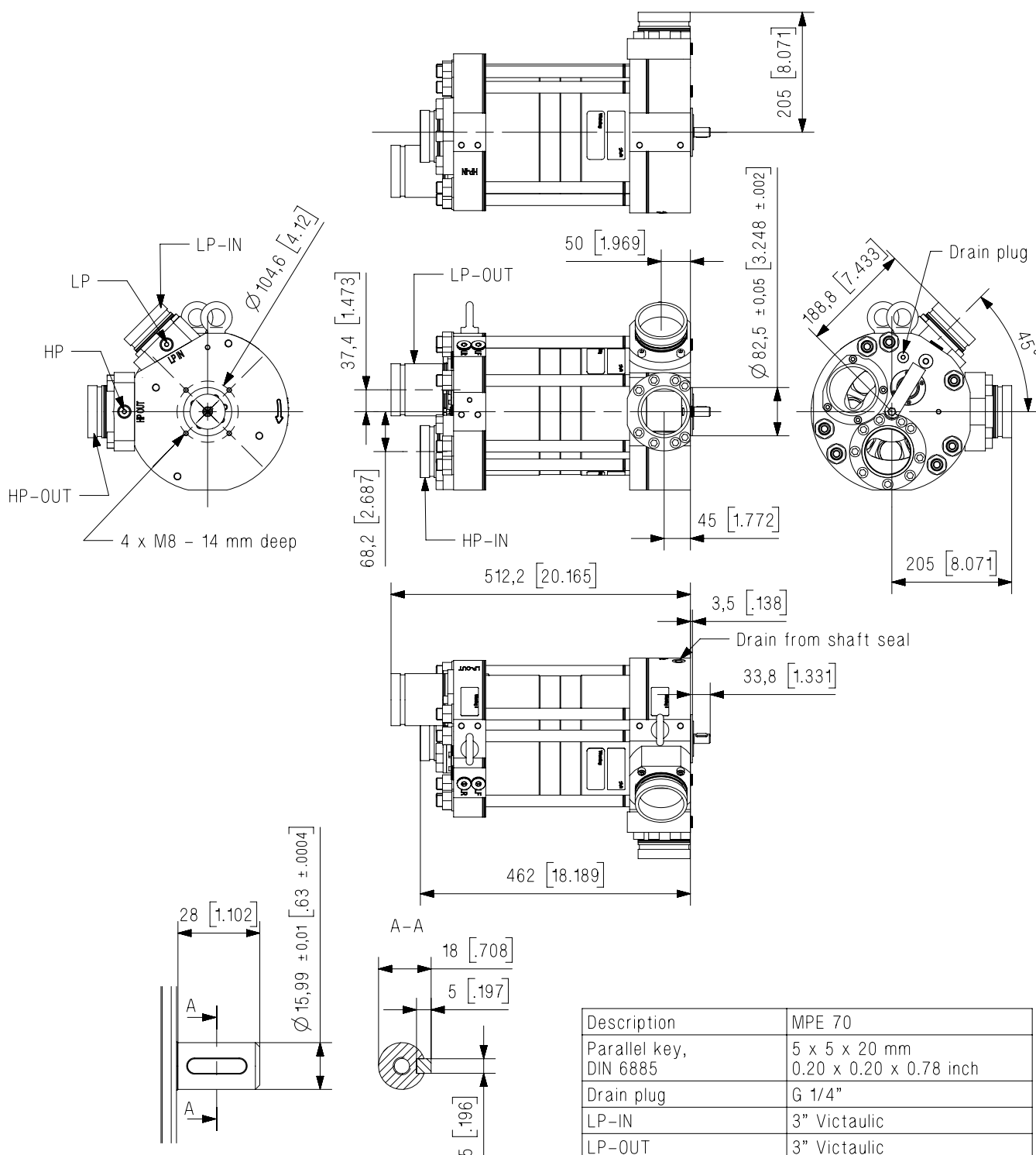

Dimensions without tolerances acc. to ISO 2768-1 designation C.

Description	MPE 70
Parallel key, DIN 6885	5 x 5 x 20 mm 0.20 x 0.20 x 0.78 inch
Drain plug	G 1/4"
LP-IN	3" Victaulic
LP-OUT	3" Victaulic
HP-IN	3" Victaulic
HP-OUT	3" Victaulic
Drain from Shaft seal	G 1/4"

8.2 MPE S 70 with IE3 motor 2.2 kW
on base frame vertical - front mounted

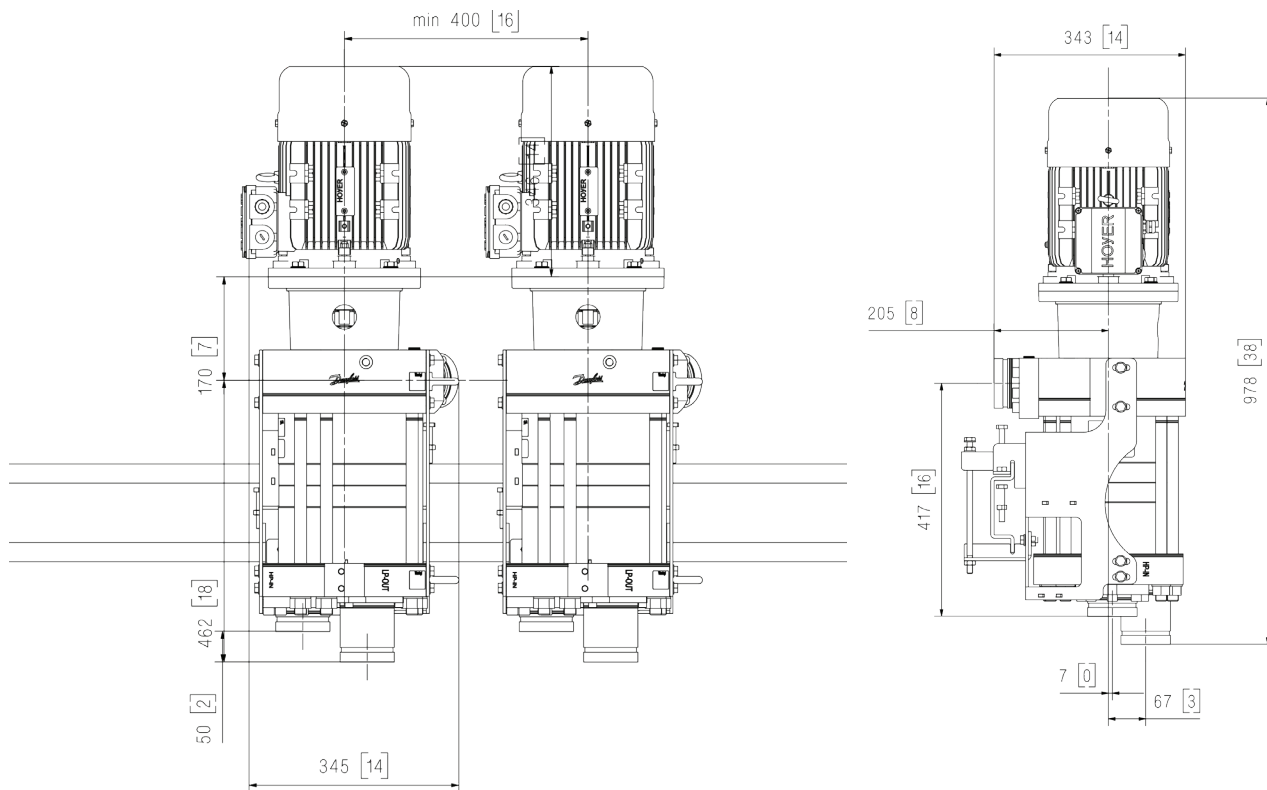
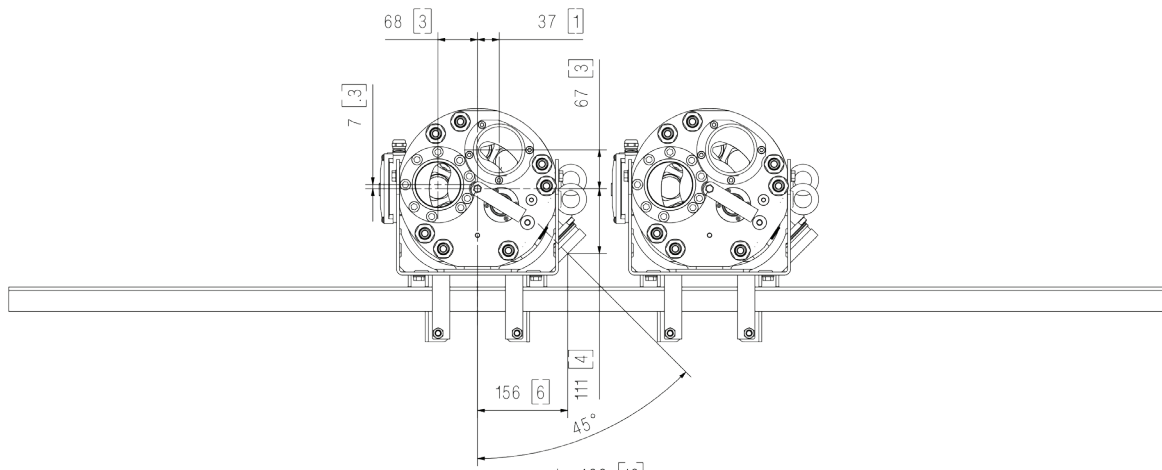

9. Accessories

Description	Type	Code no.
MPE S 70 coupling kit		180Z4110
MPE S 70 coupling		180Z4106
Bracket for 1 MPE S 70		180Z4107
2 m rail without bracket		180Z4108
Electrical motor	IEC112M 2.2 kW 6 pole	180Z4109

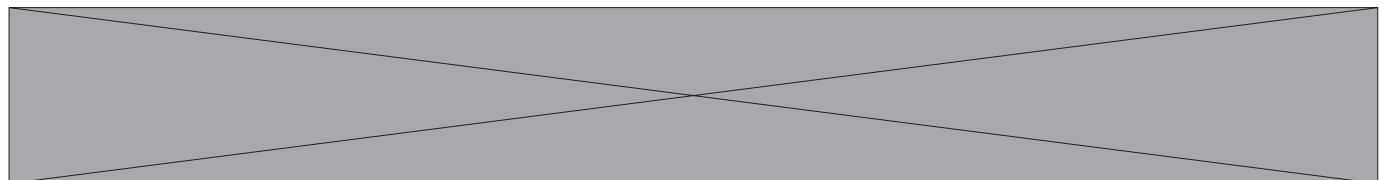

Instruction

Energy recovery device

MPE S 70

Installation instructions

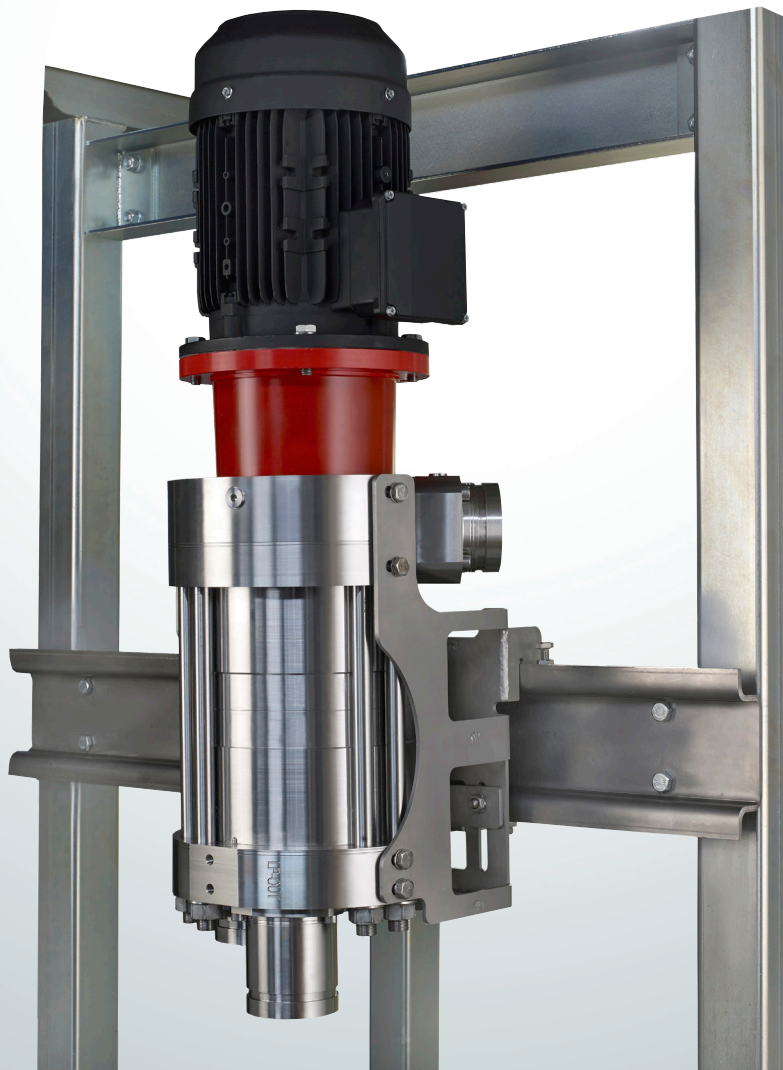

Table of Contents**Contents**

1.	Introduction	41
1.1	Symbols	41
1.2	General	41
1.3	Target group	41
1.4	MPE S 70 tool kit	41
1.5	Additional technical document	41
2.	Main parts	42
3.	Transport and handling	42
3.1	Use of lifting eye	42
3.2	Lifting unit into vertical position:	43
4.	Assembling MPE S 70 to electric motor	44
4.1	Installing support feet	44
4.2	Bell housing and coupling	44
4.3	Installing coupling and bell housing	45
5.	Orientation	46
6.	Danfoss bracket and rail system	46
6.1	Rail	46
6.2	Bracket	47
6.3	Adjustment possibilities for the bracket	48
7.	Connecting the MPE S 70 to the manifolds	48
7.1	Pipe connections	48
7.2	Manifolds	48
8.	Installing and alignment	49
8.1	Installing the MPE S 70 on the rail	49
8.2	Alignment of the units on the rail	49
9.	Removing transit screw	50
10.	Grounding	50



1.4 MPE S 70 tool kit

Some of the tools are required for the installation of the MPE S 70.



MPE S 70 tool kit (180Fxzxx):

Tool set 180F4177:

- Lifting eye M6
- Lifting eye M8
- 2 x Lifting eye M12
- Torque wrench 4-20 Nm
- Torque wrench 20-100 Nm
- Torque wrench 60-340 Nm
- Extension 3/8" , length 250 mm
- 2 x Screwdriver 5,5 x 1 mm
- Screwdriver small
- Nylon Hammer
- Wrench 10 mm
- Wrench 30mm
- Hex socket 6 mm, 3/8"
- Hex Socket 10 mm, 3/8"
- Hex Socket 30 mm
- Socket 17mm 3/8
- Allen key 2.5mm
- Allen hex head 5mm (3/8)
- Allen hex head 8mm (3/8)
- 2 x Screw M6x60
- 2 x Washer Ø12.0/Ø6.4
- 2 x Nut M6
- 2 x Screw M8x50
- Tool for backup ring
- 2 x Tool for valve plate
- Tool for shaft seal
- Calibration tool
- 4 x Feet
- 8 x M10 x25 (feet)
- 8 x Washers Ø12.6 for feet

1. Introduction

1.1 Symbols



Indicates a situation which will or could result in personal injury and/or damage to the pump.



Indicates a situation which will or could result in damage to the pump and its function .

1.2 General

This document covers the instructions for installation of the MPE S 70.



All personnel who are responsible for the installation of the MPE S 70 unit must read and fully understand these instructions before:

- Transporting of the MPE unit.
- Lifting the unit.
- Installing the MPE unit on a frame.
- Connecting the MPE unit to the fluid system

1.3 Target group

This manual is intended for use by personnel with qualified training and experience in installing of a Sea Water Reverse Osmosis (SWRO) or Brackish Water Reverse Osmosis (BWRO) system.

To prevent cold welding, Danfoss recommend to use thread lubricant for all screw threads for installing the MPE S 70 (here after only referred to as lubricate) and first tighten the screws by hand.

1.5 Additional technical document

For below Design guide, please contact Danfoss High Pressure Pumps.

Document name	Content
Design guide: 180R9367 Pipe connection	Describes how to make hard piping with Victaulic® clamps

2. Main parts

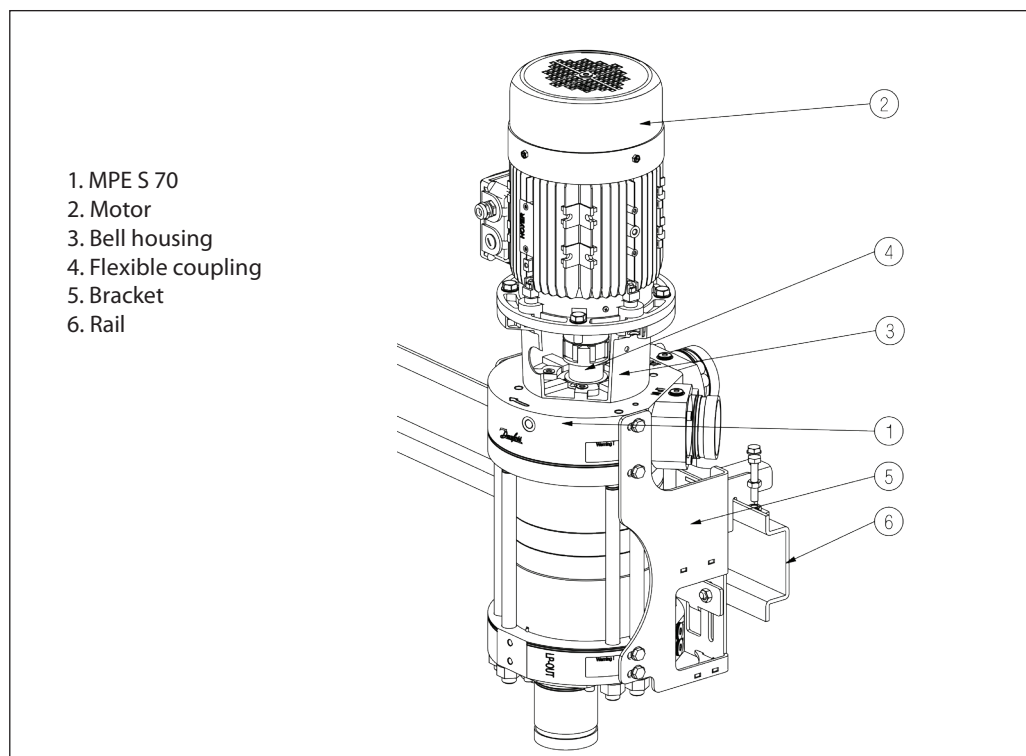

- 1. MPE S 70
- 2. Motor
- 3. Bell housing
- 4. Flexible coupling
- 5. Bracket
- 6. Rail

3. Transport and handling

Personnel involved in lifting and transportation of the equipment must be trained in proper handling and safety procedures. Observe the local regulations regarding lifting. Use suitable, permitted lifting equipment. Be aware of individuals located in the operation area while lifting the component.

The weight of the MPE S 70 including electric motor can be found in the datasheet. Use suitable lifting devices, e.g. an overhead crane or forklift.



When lifting the unit use the lifting eyes and jacking beam (not supplied by Danfoss). Make sure that the load is balanced before attempting the lift.



Do not use connections/nozzles for lifting. Do not use one sling.

3.1 Use of lifting eye

The M12 lifting eyes supplied with the MPE S 70 are to be used for straight lift only.

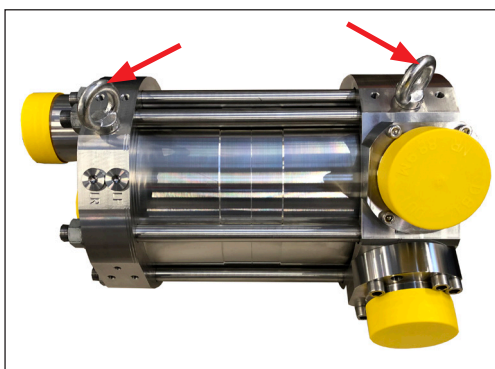

For inclined lift use the lifting eyes from the tool set.

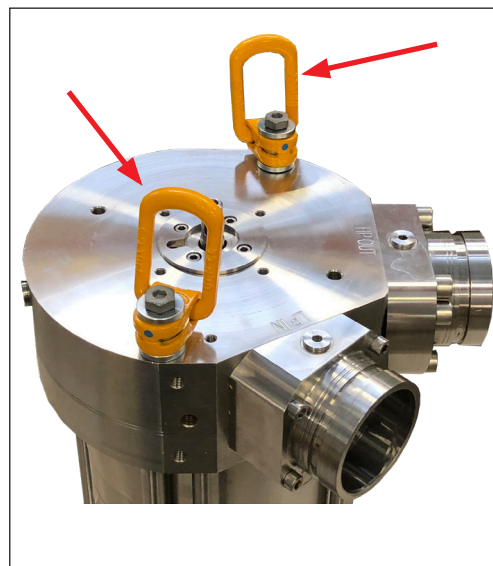

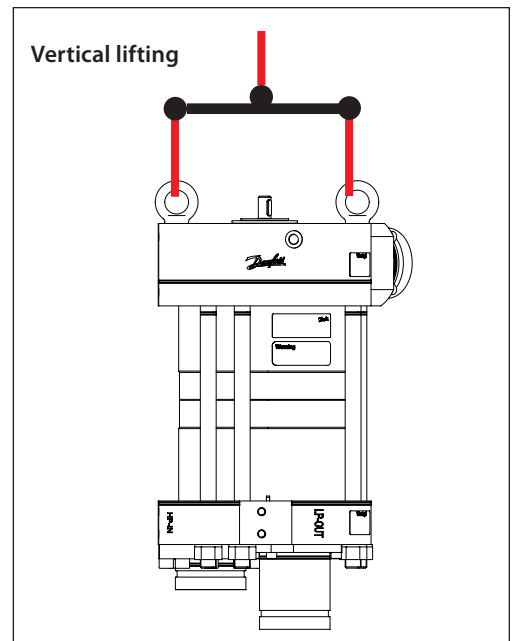
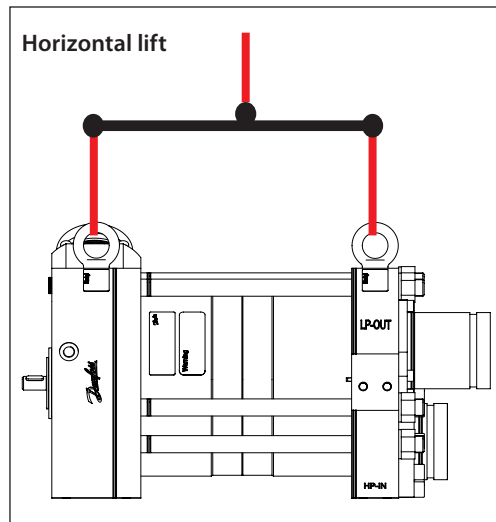

To protect the connectors during lifting place the MPE S 70 with plastic caps on the connectors on a wooden board.

Keep plastic caps on until MPE S 70 is installed to the base frame.

3.2 Lifting unit into vertical position:

Use jacking beam (not supplied by Danfoss) and two slings connected to the two lifting eyes for inclined lift from the tool kit installed to the thread holes at the shaft end of MPE S 70. To prevent damaging the connectors balance the unit by pressing the motor down until the unit is in vertical position.

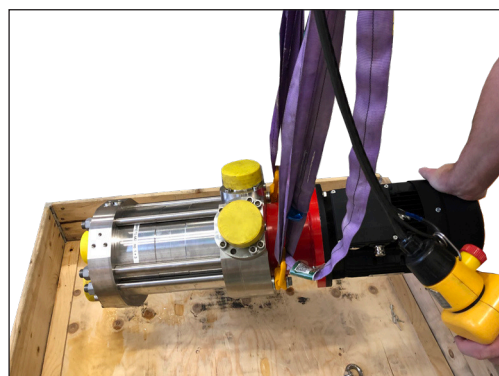

4. Assembling MPE S 70 to electric motor

4.1 Installing support feet

The motor can be installed either before or after the MPE unit is placed on the rail. If it is not installed on the rail, the MPE S 70 is positioned vertically by installing the four support feet from the tool set.

Tighten the bolts with 30 Nm.



4.2 Bell housing and coupling

The MPE S 70 is connected to the electric motor by the bell housing and a flexible coupling. See section 2. Main parts

The bell housing and coupling can be supplied by Danfoss.

For other suppliers of the bell housing:

The MPE S 70 shaft and motor shaft should be aligned within 0.2 mm / 0.008 in.

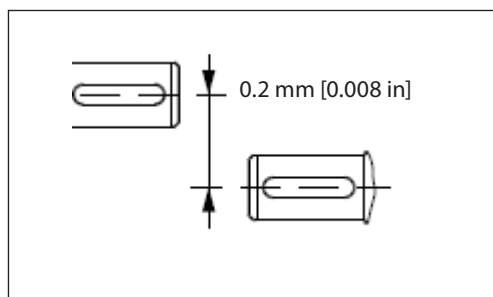

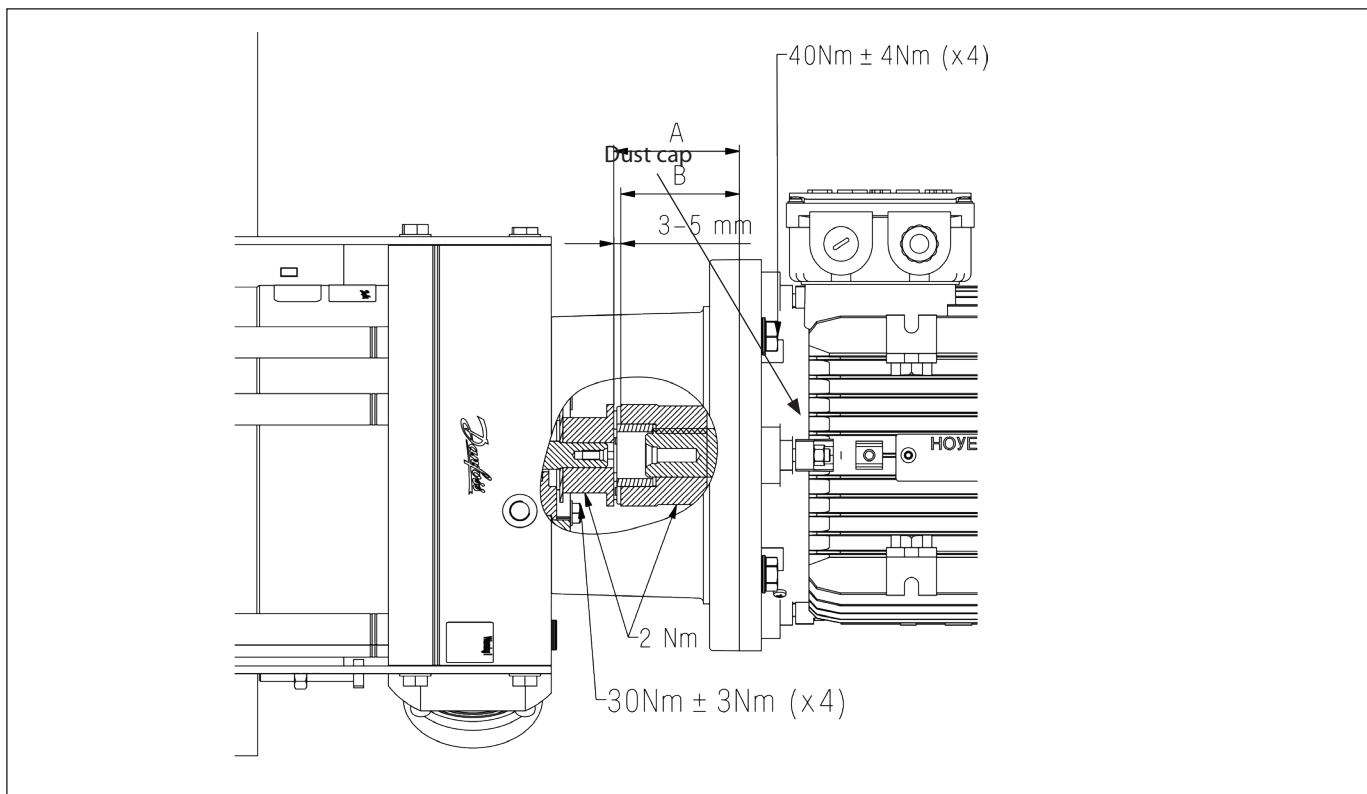

1. Check that the dust cap is placed on the MPE 70 shaft. Mount the coupling for the MPE S 70 on the shaft all the way down to the dust cap and press down for tight contact. Tighten the set screw according to specification.
2. Mount the bell housing on MPE S 70. Secure nuts with the right torque.
3. Measure the longest distance "A" from top of bell housing to the bottom of coupling claw.
4. Mount the coupling on motor shaft.
5. Measure from motor flange to the top of the coupling. That measurement "B" shall be 3 - 5 mm (0.12 - 0.2 inch) shorter the measurement "A".
6. Verify the measurement and secure the coupling with the right torque on the set screw. Mount the elastic gear ring and mount the bell housing/MPE S 70 on the motor. After mounting verify the distance between the coupling hubs to be 3 - 5 mm (0.12 - 0.2 inch) axial. The check can be done through the inspection hole of the bell housing.
7. Secure flange bolts with the right torque.

Note:
 Any axial and radial load on the shaft must be avoided.

If alternative mounting is required, please contact Danfoss for further information

5. Orientation

The MPE S 70 is built for vertical installation. The electric motor must be placed above the MPE S 70.

The MPE S 70 is connected to the electric motor by the bell housing.

The motor can be rotated in any direction for easy access to the terminal box

6. Danfoss bracket and rail system

Danfoss recommends using the MPE S 70 together with mounting bracket 180Z4107 and rail 180Z4108, see section 2 Main parts.

 **The Danfoss bracket and rail system is to be used only with hard piping to the MPE S 70 connections.**

Although the mounting rail is of sturdy design, it can flex or bend when it is installed bolted to a frame. Therefore, the rail should always be installed to a rigid steel frame.

 **An unlocked bolt can result in personal injury and/or damage to the MPE S 70.**

6.1 Rail

The rail must be bolted to a frame so the rail is supported for every one meter. The rail is supplied without holes for the bolts.

Danfoss does not supply the bolts for mounting the rail to the frame. Danfoss recommends M12 bolts A4-80. Bolt tightening torque acc. to recommendation from the bolt supplier. Make sure that the bolts are properly locked and will stay locked over time.

 **The rail must be supported on both sides of the MPE S 70**

Recommended hole pattern for rail

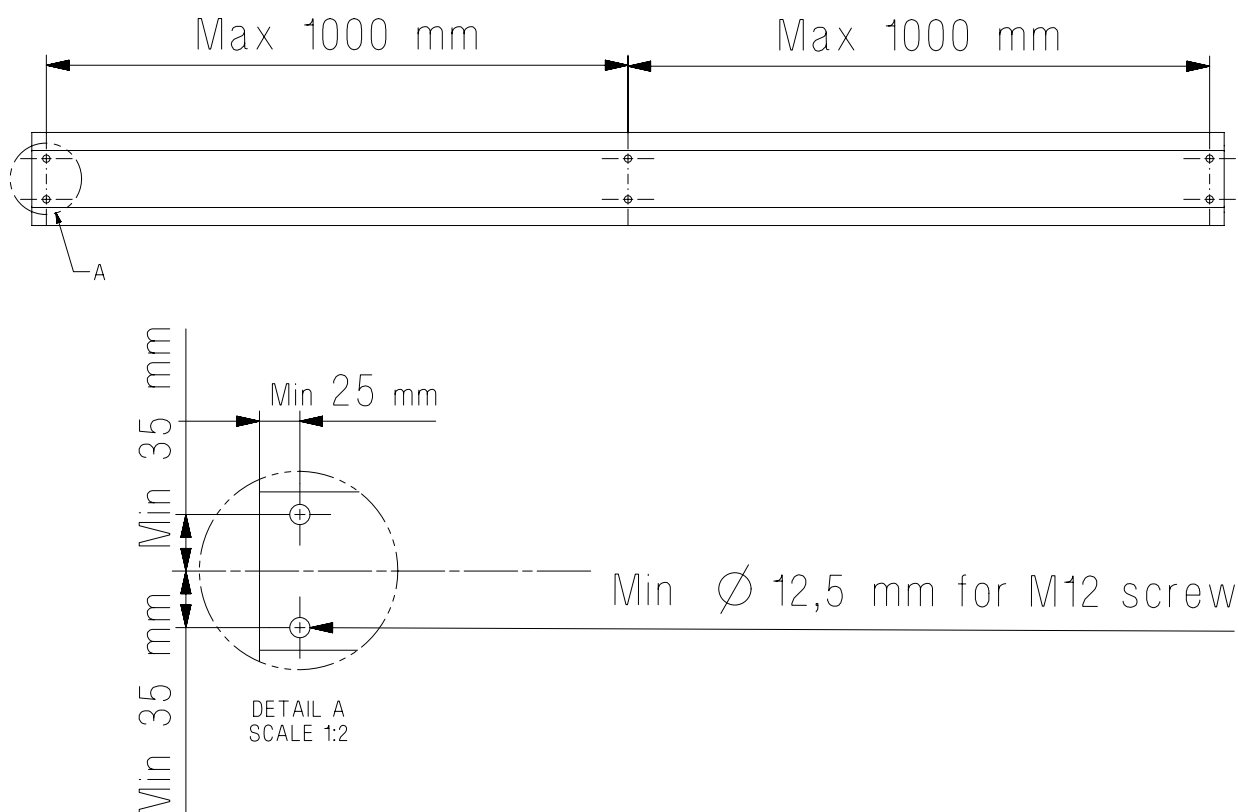

Spacing of MPE S 70 on the rail
 Danfoss recommends a minimum distance of 400 mm between the MPE's.

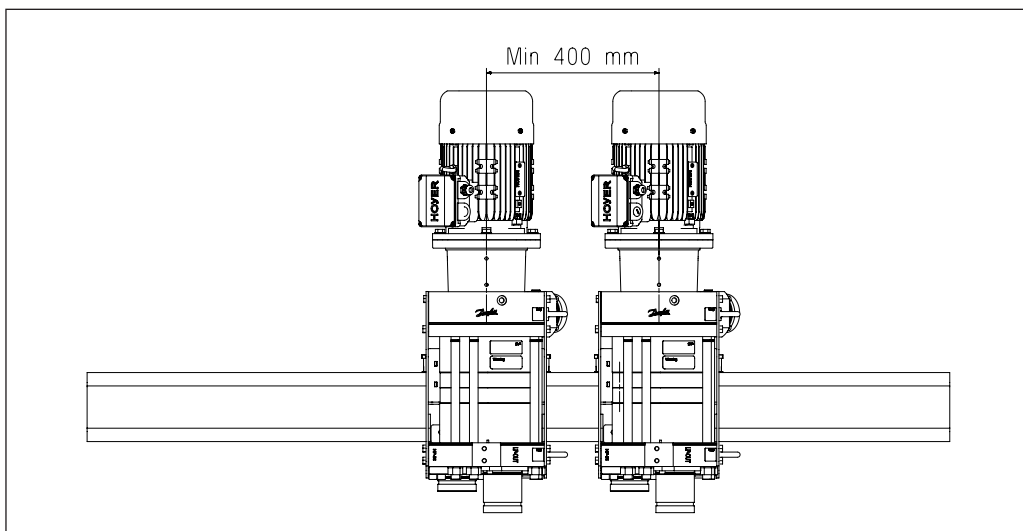

6.2 Bracket

The bracket supplied by Danfoss consists of:

1. Main bracket
2. Bottom piece - loosely mounted to the bracket
3. 8 x M10 bolts – in plastic bag
4. 2 x height adjustment screws mounted to the bracket
5. 2 x safety screws – in plastic bag
6. 2 x M10 nuts
7. 10 x washers – in plastic bag

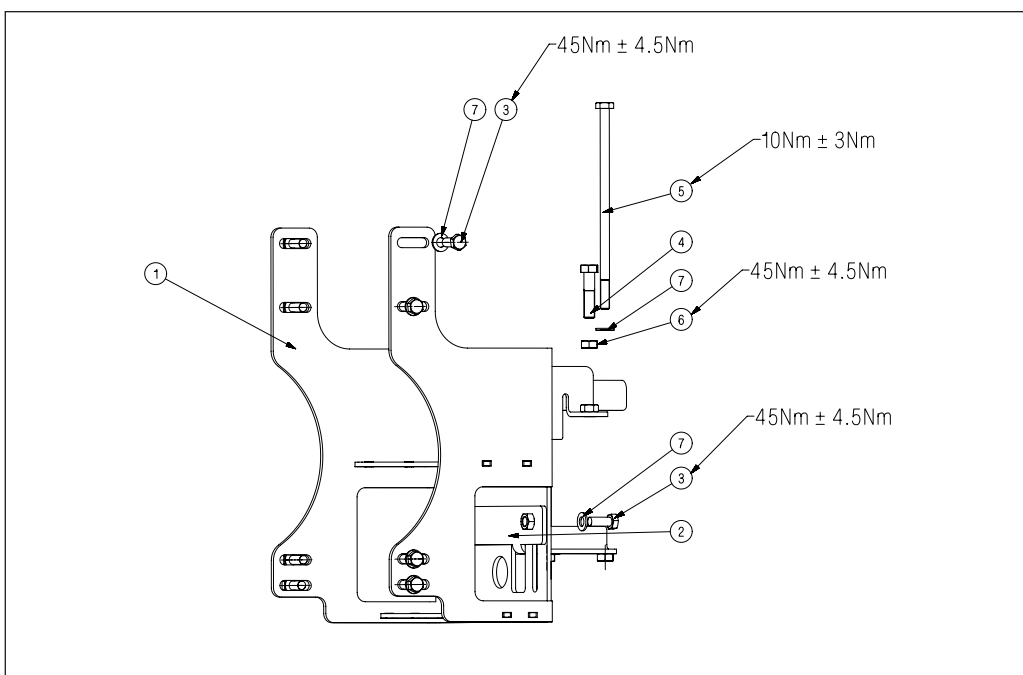

6.3 Adjustment possibilities for the bracket

The Danfoss bracket allows for adjustment in X-, Y-, Z- direction during the alignment proces.

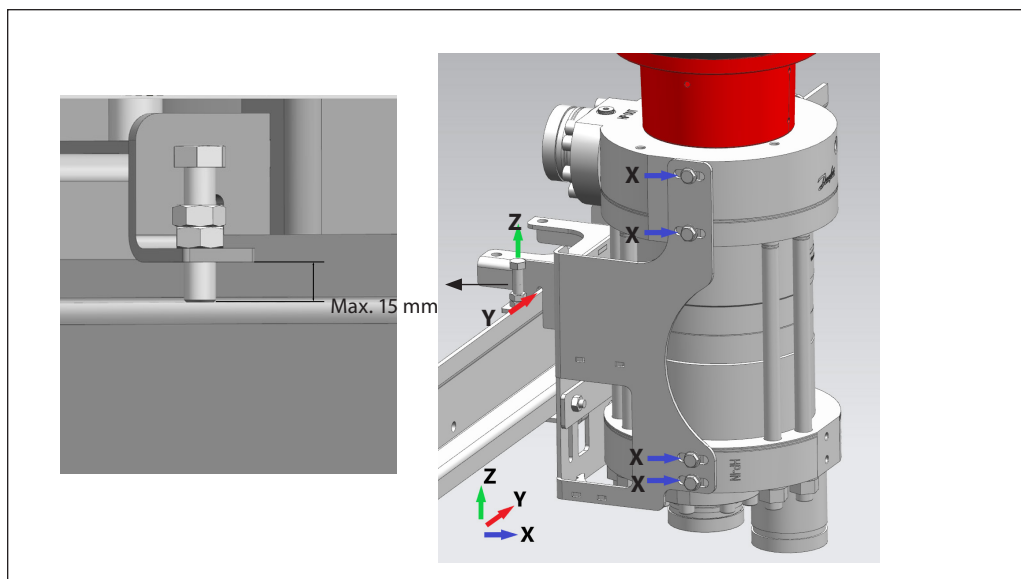

7. Connecting the MPE S 70 to the manifolds

7.1 Pipe connections

The MPE connection ports are designed for hard piping. Danfoss recommends following the Guideline 180R9367 - Pipe connection. This guideline is based on the use of Victaulic® Style 77 Flexible Coupling. Spool pieces must be manufactured according to the "Victaulic® (OGS) cut groove specifications" or similar. To allow for inaccuracies in the manifolds and to ensure an easy installation we recommend mounting a spool piece with a minimum length of 80 mm on the HP-out connection.

7.2 Manifolds

The manifolds must have enough support to prevent them from moving when getting pressurized. The manifolds must be clean inside before connecting them to the MPE S 70.

8. Installing and alignment

The bracket is attached to the MPE S 70 unit by four x M10 bolts each side, positioned in the center of the sleeve, for later adjustments. Tighten the bolts - see section 6.2. Lift the unit with motor and bracket using suitable crane or winch. We recommend the spool piece for HP out to be installed to the manifold before installing the MPE S 70 unit on the rail.

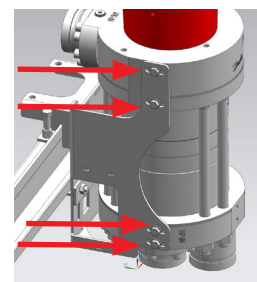

8.1 Installing the MPE S 70 on the rail

Place the unit on the rail. Both sides of the bracket must grip the rail before lowering the unit.

Slide the bottom piece of the bracket up to grip the rail. Allow for some play. Hand tighten the screws on the bottom bracket to allow for adjustment during alignment

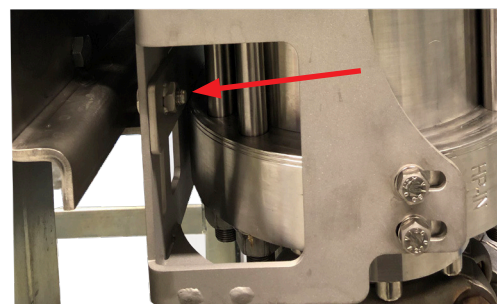



8.2 Alignment of the units on the rail

The rail and MPE S 70 must be aligned with the manifolds to avoid stress or bending.

The HPout connector is aligned first. Then the spool piece for the HPin side can be manufactured to length. The LP piping is mounted last. Start with aligning the first unit on the rail, then the last unit and then the units in between until all the units have been aligned.

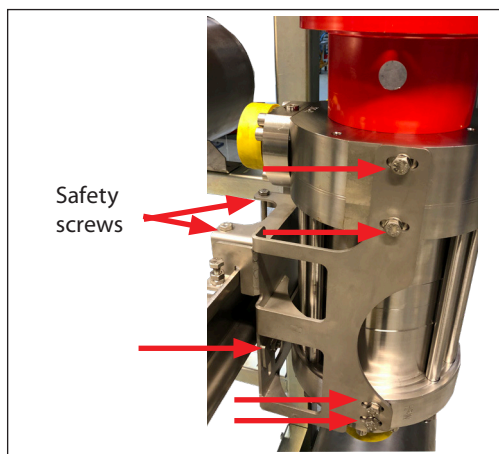
 **Misalignment may cause stress and/or damage to the Victaulic connections.**



 **Do not pressurize the units without proper alignment.**

 **After aligning secure the unit on the rail by tightening all the screws incl. the safety screws with the specified torque, see section 6.2.**

Instruction

MPE S 70 Energy recovery device

9. Removing transit screw

When the installation is done, the transit screws at the center of the port flange must be removed and replaced by the plug supplied in the plastic bag with the unit.



Note: During longer period of transportation it is recommended to install the transit screw.

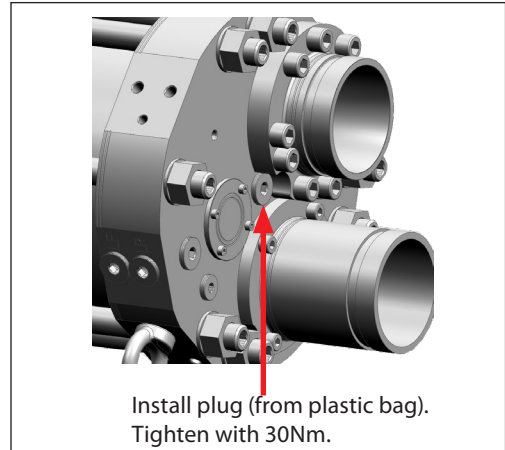
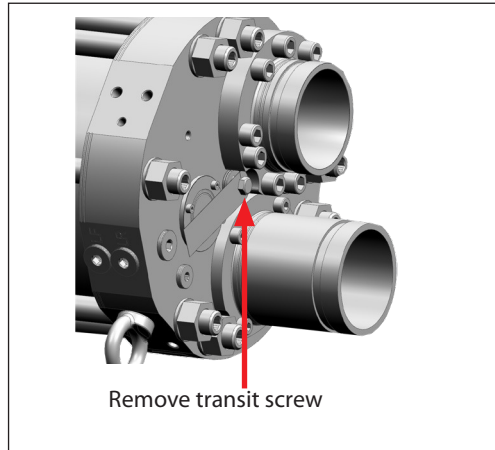

10. Grounding

To limit/prevent galvanic corrosion, MPE S 70 skid should be properly grounded. All parts in the system must be electrical potential equalized to a single reference point (grounding point). It is recommended that the electrical resistance in the grounding cable is equal to or below 0.25 Ohm towards the grounding point.

Use one of the M12 thread holes in the motor flange of the MPE S 70 for grounding

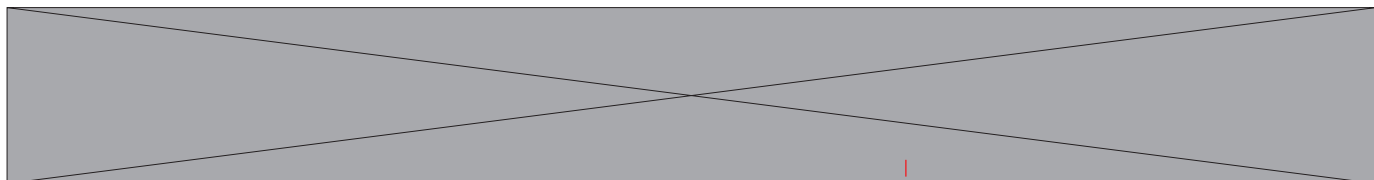
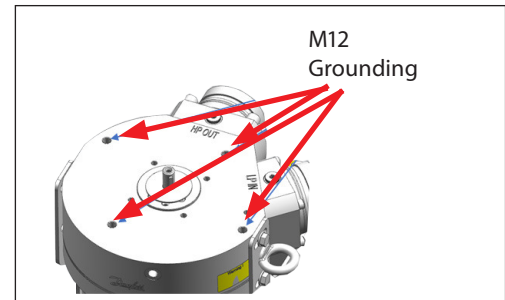

Piping connections



Typically, manifolds for multiple Energy Recovery Devices are made in hard piping, using flexible couplings between the devices discharge and inlet ports.

This paper shows some design rules based on Victaulic® Flexible couplings style 77 in Duplex. Other supplier of flexible couplings may have different design rules.

(Victaulic® is a registered name of Victaulic)

It is always the customer's responsibility to design the manifolds according to the design rules of the flexible couplings used.

Description

Experience in the market shows that precise welding of a steel manifold with multiple connections is difficult. The individual position of the manifold connections may exceed the flexibility of a single flexible coupling.

- To reduce stress on the discharge and inlet it is preferred to use flexible hoses or a minimum of 2 flexible couplings combined on the same pipe.
- When using hard piping, it is important to allow a gap between each individual Victaulic connection. See "Spacing" in table below.
- The use of only one flexible coupling to discharge or inlet should be accurately controlled to ensure the proper alignment of the manifold.
- Do not force any misaligned pipes to connect to discharge or inlet.
- Do not use the discharge or inlet connection as support for pipes. The pipes must have separate support close to the end of the pipe.

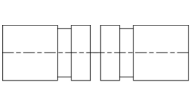
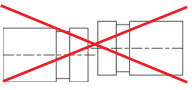
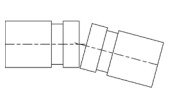
Victaulic® Flexible coupling Style 77DX Cut grooved Pipe SC40	 Spacing [mm]	 Max. radial offset ¹⁾ [mm]	 Max. angle ²⁾ [Deg.] or [mm]	End load ³⁾ [N]
1½"	3.2	0 mm	3° - 52' or 66	15120
2"	3.2	0 mm	3° or 52	23575
2½"	3.2	0 mm	2° - 30' or 44	34250
3"	3.2	0 mm	2° or 36	51150
4"	6.4	0 mm	3° - 12' or 56	84500
6"	6.4	0 mm	2° - 24' or 36	184000

Design guide

MPE S 70 Energy recovery device

Notes

Reference should always be made to the I-100 Victaulic® Field Installation Handbook for the product you are installing
www.victaulic.com

All References are based Victaulic “Duplex – grooved couplings 17.20”.

- ¹⁾ At least 2 flexible couplings must be used to compensate radial misalignment. Angular deflection of each joint must not exceed Maximum angle from centerline. Se example reference “Victaulic – Design Data 26.01 page 3.
- ²⁾ The grooved piping method will not allow both maximum linear movement and maximum angular movement simultaneously at the same joint.
- ³⁾ End Loads are total, from all internal and external loads, based on duplex stainless steel pipe.

Example

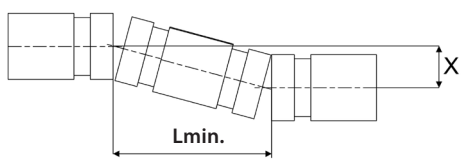
<p>Victaulic® Flexible coupling Style 77DX Cut grooved Pipe SC40</p>	 <p>Minimum length at radial offset [mm]</p>	
<p>3" pipe</p>	X	Lmin
	1	1000/36 x 1 = 28 mm
	2	1000/36 x 2 = 56 mm
	3	1000/36 x 3 = 84 mm
	4	1000/36 x 4 = 111 mm
	5	1000/36 x 5 = 139 mm

Pipe support

Flexible coupling Styles 77 and others standard grooved-type couplings allow angular, linear and rotational movement at each joint, to accommodate expansion, contraction, settling,

vibration, noise and other piping movement. This must be considered when determinate hanger and support bracing. See Reference Victaulic – Design Data 26.01.

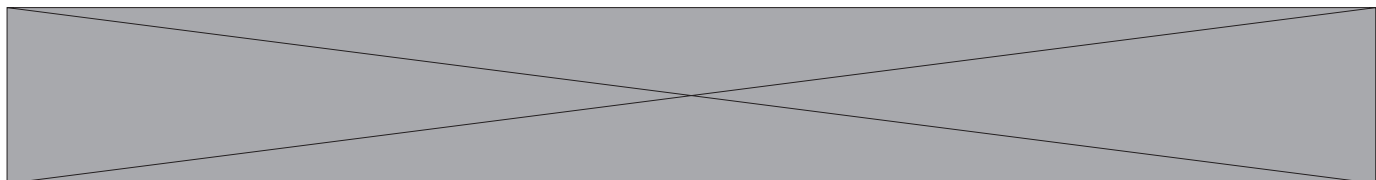

ENGINEERING
TOMORROW

Danfoss

Parts list

Energy recovery device MPE S 70

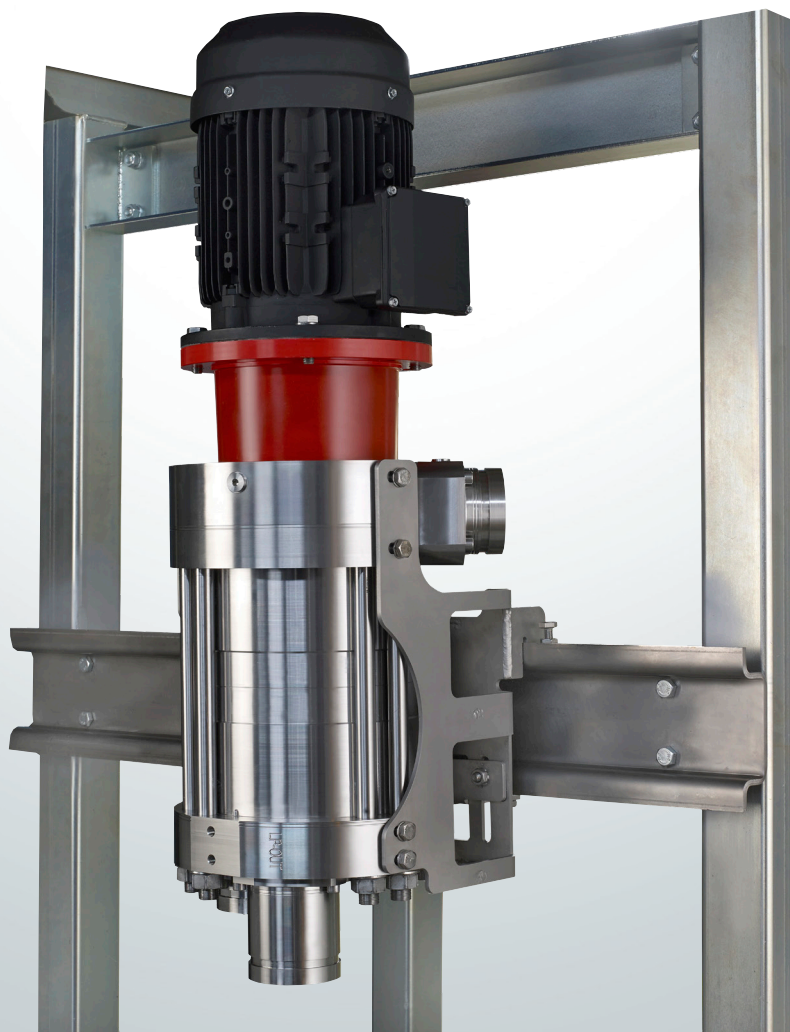

Table of Contents

Table of Contents

1.	General54
2.	Parts list MPE S 7055
3.	Exploded view MPE S 7056
4.	Tool set57

1. General



The parts list provides an overview of the content of the various service kits for the MPE S 70 as well as exploded view of the MPE S 70.

Parts list

MPE S 70 Energy recovery device

2. Parts list
MPE S 70

MPE S 70
Energy recovery device

Pos.	Qty.	Description	Material	180F4170 Shaft Seal Kit	180F4171 Screw Kit	180F4172 Seal kit	180F4173 Distance plate	180F4174 Port plate kit	180F4175 Valve plate kit
101	2	O-ring 200,00 x 3,00	NBR 72			X			
102	4	Clips for retainer plate	PEEK					X	
103	4	Pin ø10,5 x 2	Super Duplex		X			X	
104	1	Port plate (Feed)	PEEK / Super Duplex					X	
105	2	Valve plate	Super Duplex						X
106	16	Back-up ring	PTFE			X			
107	16	O-ring 45,00 x 2,00	NBR			X			
108	1	Distance plate	PPC, PEEK				X		
111	1	Cylinder barrel	Super Duplex						
112	1	Port plate (Brine)	PEEK / Super Duplex					X	
113	2	Pin Ø4 x 14 (A4)	AISI 316		X	X			
114	1	Housing	Super Duplex						
115	7	Stud bolt M20	Super Duplex						
116	7	Washer ø21 x ø34 x 3 A4	AISI 316		X				
117	7	Nut M20x1,5 A4	AISI 316		X				
118	1	Port flange	Super Duplex / PEEK						
119	4	O-ring 84,00 x 3,00	NBR			X			
120	9	Screw M12x30 A4-80	AISI 316		X				
121	1	3" VIC. Connector HP IN	Super Duplex						
122	4	Screw M8 x 20 A4-80	AISI 316		X				
123	1	3" Vic. connector LP Out	Super Duplex						
124	2	Lifting eye M12	AISI 316						
125	3	O-ring 11,0X2,0	NBR			X			
126	3	Bleeding plug G1/4"	Super Duplex						
127	4	O-ring 18,00 x 2,00	Super Duplex / PEEK			X			
128	4	G 1/2" plug	Super Duplex						
129	1	O-ring ø24x3	NBR			X			
130	1	Cover for monitor	Super Duplex						
131	4	Screw 4x10 A4-70	AISI 316		X				
132	1	Screw M8 x 70 A4	AISI 316		X				
133	1	Nut 8,0x6,5x13,0	AISI 316		X				
134	1	Washer ø8/ø24x2	AISI 316		X				
135	1	Motor flange	Super Duplex / PEEK						
136	1	3" VIC. Connector HP OUT	Super Duplex						
137	8	M12x50 A4-80	AISI 316		X				
138	1	3" VIC. Connector LP IN	Super Duplex						
139	2	Screw M8 x 35 A4-80	AISI 316		X				
140	2	Screw M8 x 55 A4-80	AISI 316		X				
143	1	Dust cap	PPC						
144	1	Cover for shaft seal	Super Duplex						
145	4	Screw M6 x 16 A4	AISI 316	X	X				
146	1	O-ring 40,00 x 2,00	NBR	X		X			
147	1	Shaft seal ø18	NBR/hastelloy	X					
148	1	O-ring 9,25 x 1,78	NBR	X		X			
149	1	Key 5 x 5 x 20	AISI 316		X				
150	1	Pin ø6x15	Super Duplex		X				
	1	Instruction		x	x	x	x	x	x

3. Exploded view
MPE S 70

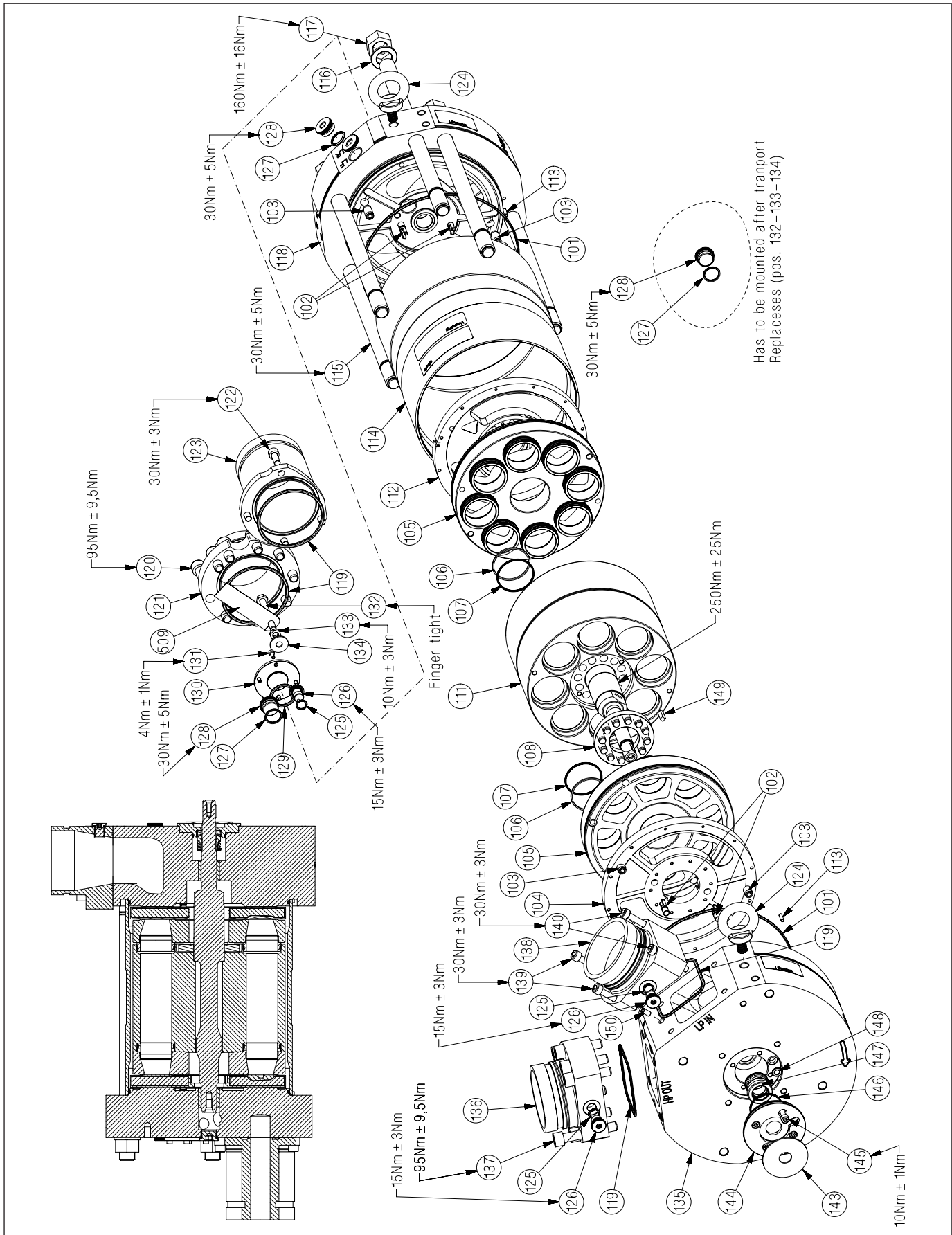

4. Tool set

Qty.	Designation	180F4177 MPE S 70 Tool kit
1	Lifting eye M6	X
1	Lifting eye M8	X
2	Lifting eye M12	X
1	Torque wrench 4-20 Nm	X
1	Torque wrench 20-100 Nm	X
1	Torque wrench 60-340 Nm	X
1	Extension 3/8", length 250 mm	X
2	Screwdriver 5,5 x 1 mm	X
1	Screwdriver, small	X
1	Nylon Hammer	X
1	Wrench 10 mm	X
1	Wrench 30 mm	X
1	Hex socket 6 mm, 3/8"	X
1	Hex socket 10 mm, 3/8"	X
1	Hex socket 30 mm	X
1	Socket 17mm 3/8	X
1	Allen key 2.5mm	X
1	Allen hex head 5 mm (3/8)	X
1	Allen hex head 8 mm (3/8)	X
2	Screw M6x60	X
2	Washer Ø12.0/Ø6.4	X
2	Nut M6	X
2	Screw M8x50	X
1	Tool for backup ring	X
2	Tool for valve plate	X
1	Tool for shaft seal	X
1	Calibration tool	X
4	Feet	X
8	M10 x25 (feet)	X
8	Washers Ø12.6 for feet	X

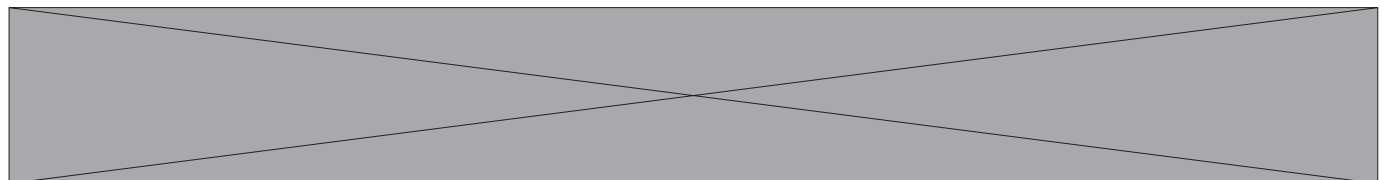



Electric Motors

Motor Manual

hoyermotors.com

Manual

HOYER
MOTORS

General

This manual concerns the following types of standard induction motors from Hoyer:

HMA3, HMC3, HMA2, HMC2, HMD, HMT, MS, Y2E1, Y2E2, YDT
These motors are manufactured in accordance with IEC/EN 60034-4 and IEC/EN 60072.

Motors are rated for the ambient temperature range -20°C to +40°C and site altitudes ≤1000 m above sea level.

Low-voltage motors are components for installation in machinery. They are CE marked according to the Low Voltage Directive 2014/35/EU.

Motors not fulfilling the IE3 efficiency level must be equipped with a variable speed drive when used in EU.

Transport and storage

Check the motor for external damage immediately upon receipt and, if found, inform the forwarding agent right away. Check all rating plate data, and compare it with the requirement of the motor.

Turn the shaft by hand to check free rotation, remove transport locking if used.

Transport locking must be used again for internal transport also. It is also important that transport locking is used when motors are transported mounted on equipment.

All motors should be stored indoors, in dry, vibration- and dust-free conditions.

Lifting eyebolts must be tightened before use. Damaged eyebolts must not be used, check before use. Lifting eyes at motor must not be used to lift the motor when it is attached to other equipment.

Before commissioning, measure the insulation impedance. If values are ≤ 10MΩ at 25°C, the winding must be oven dried. The insulation resistance reference is halved for each 20°C rise in motor temperature.

It is recommended that shafts are rotated periodically by hand to prevent grease migration.

Installation

The motor must be fixed on a stable, clear and flat foundation. It must be sufficiently rigid to withstand possible short circuit forces.

It is important to ensure that the mounting conditions do not cause resonance with the rotational frequency and the doubled supply frequency.

Only mount or remove drive components (pulley, coupling,

etc.) using suitable tools, never hit the drive components with a hammer as this will cause damage to the bearing.

The motor are balancing with half key, ensure that the drive components are also the same.

Correct alignment is essential to avoid bearing, vibration and shaft failure.

Use appropriate methods for alignment.

Re-check the alignment after the final tightening of the bolts or studs.

Check that drain holes and plugs face downwards. We recommend opening the drain hole for motors placed outdoors and not running 24 hours / day, so that the motor can breathe, thus ensuring a dry motor.

Electrical connection

Work is only permitted to be carried out by qualified specialists and must to be carried out in accordance with local regulations.

Before work commences, ensure that all power is switched off and cannot be switched on again. This also applies to the auxiliary power circuits, e.g. anti-condense heaters.

Check that supply voltage and frequency are the same as rated data.

Motors can be used with a supply deviation of ± 5% voltage and ± 2% frequency, according to IEC60034-1.

Connection diagrams for main supply and accessory as PTC or heater are located inside the terminal box.

Connections must be made in such a way as to ensure that a permanently safe electrical connection is maintained, both for the main supply and the earth connection.

We recommend that crimped connections are made in accordance with IEC 60352-2.

Tightening torques for terminal board screws:

Thread	M5	M6	M8	M10	M12	M16	M20	M24
T.(Nm)	2.5	3.5	7	12	18	35	55	80

Ensure that the terminal box is clean and dry.

Unused glands must be closed with blind caps.

Check the terminal box gasket before it is remounted.

Maintenance

Inspect the motor at regular intervals, keep it clean and ensure free ventilation air flow, check the condition of shaft seals and replace if necessary. Both electrical and mechanical

connections must be checked and tightened if necessary. Bearing size and type are specified on the rating plate. Motor types HMA3 and HMC3 is as standard with lifetime greased bearings in motors size ≤180 for cast iron and size ≤132 for aluminium. Motor types HMA2 and HMC2 is as standard with lifetime greased bearing in motors size ≤225. Motor types MS and Y2E is as standard with lifetime greased bearing in motors size ≤160.

Typical duty hours for lifetime lubricated bearings.

Frame size	Poles	Typical lifetime
56 - 160	2 - 8	40,000h
180	2	35,000h
200	2	27,000h
225	2	23,000h
180 - 225	4 - 8	40,000h

Motors with a re-greasing system must be lubricated with high quality lithium complex grease, NLGI grade 2 or 3, with a temperature range of between -40°C to +150°C. Motors are normal fitted with a data plate with greasing information; if it is missing use the following re-greasing intervals.

Frame size	Grease (g)	2 pole (h)	4 pole (h)	6 pole (h)	8 pole (h)
160	20	4200	7000	8500	8500
180	20	4200	7000	8500	8500
200	25	3100	6500	8500	8500
225	25	3100	6500	8500	8500
250	35	2000	6000	7000	7000
280	35	2000	6000	7000	7000
315	50	1500	5500	6500	6500
355	60	1000	4000	5000	6000
400	80	800	3000	4000	6000

Grease the motor while running, open the grease outlet plug and let the motor run 1-2 hours before the outlet grease plug is closed again.

Grease the motor for the first time during commissioning.

The following applies in general for both lifetime lubricated and re-lubricated bearings:

At 60Hz the time will be reduced by app. 20%.

Data for vertically mounted motors are half of the above values.

The table values are based on an ambient temperature of 25°C. The values must be halved for every 15K increase in bearing temperature.

Higher speed operations, e.g. frequency converter drive will require shorter greasing intervals. Typically, doubling the speed will reduce the values by 50%.

Special note for Atex Zone 22 and nA motors

Designation of motor according to IEC standard:

II 3D Ex tc IIIB T120°C

II 3G Ex nA IIC T3

The hazardous 3-phase asynchronous motors are in accordance with International standard IEC 60079-31 and IEC 60079-15.

Only one electrical installation may be installed in one specified area (zone).

Only certificated cable glands may be used. Unused glands must be closed.

Connections must be made in such a way as to ensure that a permanently safe electrical connection is maintained, both for the main supply and earth connection.

Installations must be in accordance with actual standards for installation in hazardous area.

It is recommended that the IEC standard is followed according to temperature and dust on the motor surface.

The use of motors with so much surface dust that the motor temperature increases is not permitted.

Regularly cleaning is recommended.

The radial shaft sealing ring is part of the ATEX certification. It is important that the ring is always intact.

The shaft sealing must be regularly checked, and if dry it must be lubricated. It is recommended that the seal is re-lubricated regularly.

Always use the original seal ring when replaced.

Replacing bearings also means replacing the seals.

All machines must be inspected regularly for mechanical damage.

The user is responsible for changing parts in accordance with the lifetime of parts, in particular: bearings, grease and lubrication of shaft sealing.

Maintenance, repairs and replacement on this type must only be carried out by qualified specialists.

Aansluitdiagram
Connection
Conexión
Collegamento
Schemat polacsen

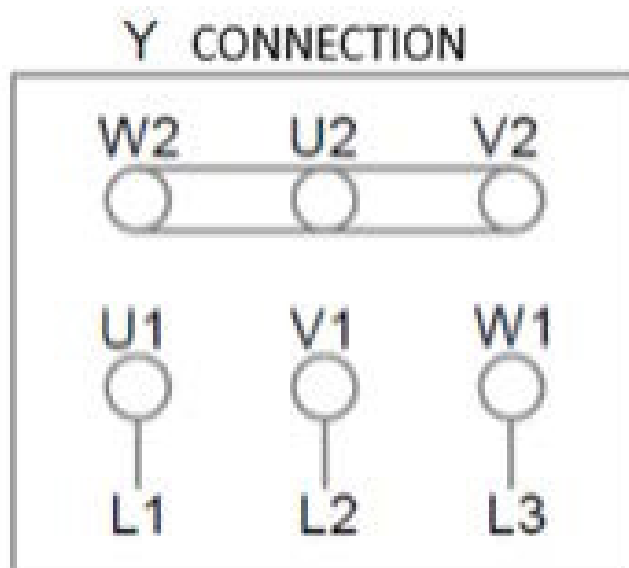
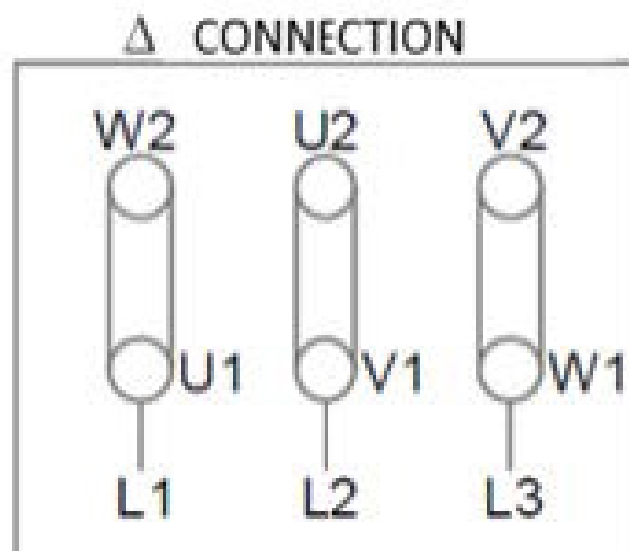

The Manufacturer: SVEND HØYER A/S
Over Hadstenevej 42
DK 8370 Hadsten
Denmark

Hereby declares that

The products: HOYER MOTORS, 3-phase induction motors

Aluminum motors	MS 56 - 180 HMAx 56 – 180
Cast iron motors	Y2E2 80 - 400 HMCx 80 – 400

HOYER MOTORS, 1-phase induction motors

Aluminum motors	ML 56 – 112 MY 63 – 112
-----------------	----------------------------

Are in conformity with the following:

Standards: IEC/EN 60034 (All relevant standards on the IEC/EN 60034 series)
Directive: Low Voltage Directive 2014/35/
EU

Motor type HMAx and HMCx is also conformity with:

Standards: IEC/EN 60079-0:2018, IEC/EN 60079-0/A11:2013,
IEC/EN 60079-15:2010, IEC/EN 60079-31:2014
Directive: Eco design for electrical motors 2009/640/EC and 2014/4EU
ATEX directive 2014/34/EU
Ex II 3D Ex tc IIIB T120°C
Ex II 3G Ex nA IIC T3

CE marking: CE

This declaration of conformity is issued under the sole responsibility of the manufacturer.

I hereby declare that the equipment's named above have been designed to comply with the relevant sections of the above referenced specifications.

Signed by: Bjarne Nør / Technical Manager

December 2018:

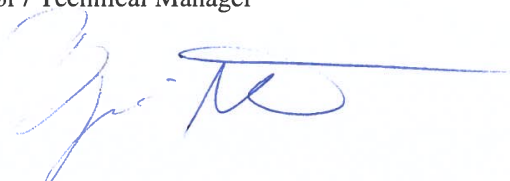

1/3

x = 2, 3

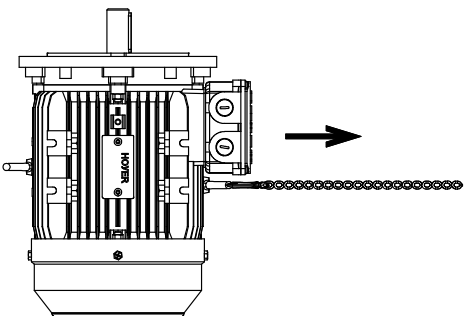

Figure 1

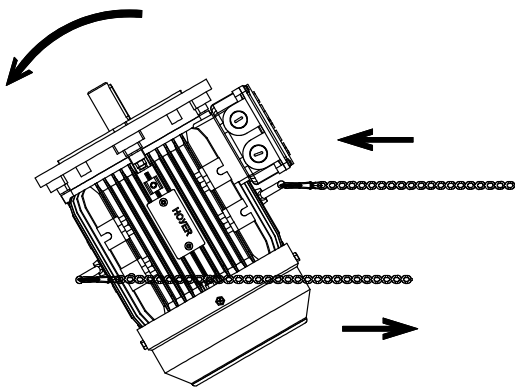

Figure 2

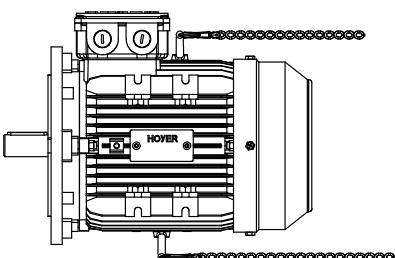

Figure 3

General procedure for lifting a motor into vertical position

For safety reasons during the transport, vertical mounted motors are usually packed and supplied in horizontal position. To place motor fitted with lifting eyebolts to the vertical position, proceed as follows:

1. Lift motor by using the top lifting eyebolt through one hoist, see Figure 1.
2. Fix the second hoist hook into eyebolt underneath.

Lower the hoist fixed to top eyebolt while lifting the second hoist which fixed to the underneath eyebolt, see Figure 2. This procedure must be carried out slowly and carefully.

3. Hold on motor to the motor to ensure that it is turning slowly and stable until the motor reaches the desired vertical position, see Figure 3.
- For vertical mounted motors the use of a spreader beam is recommended for maintaining a lifting element (chain or rope) in vertical position and thus preventing damage to the motor surface.

When motors are fitted with two or more lifting eyebolts, all supplied lifting eyebolts must be used simultaneously for the lifting procedure. It must be ensured that no rope or chains touching the motors frame or fan cover under the process. Be aware this can damage the paint and/or the fan cover.

		Hoyer Motors Overfaldensvej 12, DK-8570 Halden Tel: +45 86981799 Fax: +45 86981799 www.hoyermotors.com		BEKÆFTIGET HANDELSREJSE EDCS	
		DO NOT SCALE DRAWING		REVISION 01	
NAME TH CHNO APNO WPS OCA	SIGNATURE DATE 2020/02/	TITLE Motor lifting instruction For HMA		DWG NO 31972	SHEET OF 1
MATERIAL		WEIGHT kg	SCALE 1:1	A3	

! Hoyer Motors. All intellectual property rights and all rights in know-how in relation to this drawing may not be reproduced, stored, or transmitted in any form by any means (electronic, mechanical, photocopying, recording or otherwise) without the prior written consent of Hoyer Motors. It is to be used only for the purposes specified by Hoyer and for no other purpose.