



Thermostat

RT Differential thermostat

Description

An RT thermostat is fitted with a single-pole changeover switch.

The position of the contacts depends on the bulb temperature and the set scale value.

The RT series includes thermostats for general applications within industrial and marine refrigeration.

The RT series also includes differential thermostats, thermostats for neutral zone regulation and special thermostats with gold-plated contact surface for PLC applications.

Features & benefits

- Waterproof versions, enclosure IP66
- Wide regulating range
- Wide range of units for industrial and marine applications
- Suitable for alternating and direct current
- Interchangeable contact system
- Special versions for PLC applications
- Safety Integrity Level:
 - SIL 2 according to IEC 61508

Ordering

Product code numbers

Thermostats

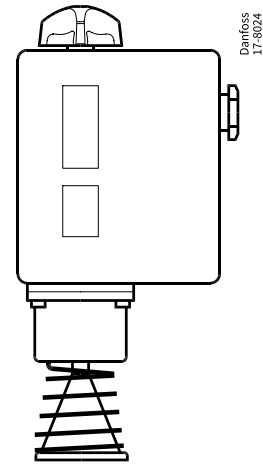
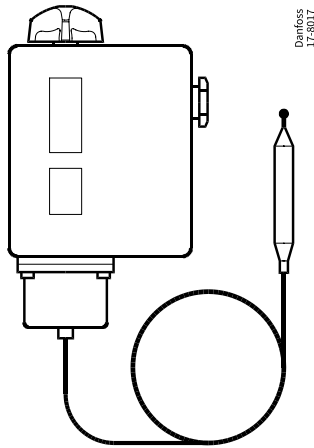

Charge	Type	Bulb type	Differential Δt			Reset	Max. bulb temp.	Capillary tube length	Code no.
			Regulation range	At min. range setting	At max. range setting				
			[°C]	[K]	[K]				
Vapour ¹⁾	RT 9	A	-45 – 15	2.2 – 10.0	1.0 – 4.5	auto	150	2	017-506666
	RT 3	A	-25 – 15	2.8 – 10.0	1.0 – 4.0	auto	150	2	017-501466
	RT 17	B	-50 – -15	2.2 – 7.0	1.5 – 5.0	auto	100	–	017-511766
	RT 11	B	-30 – 0	1.5 – 6.0	1.0 – 3.0	auto	66	–	017-508366
	RT 4	B	-5 – 30	1.5 – 7.0	1.2 – 4.0	auto	75	–	017-503666 017-503766 ⁴⁾
Adsorption ²⁾	RT 13	A	-30 – 0	1.5 – 6.0	1.0 – 3.0	auto	150	2	017-509766
	RT 2	A	-25 – 15	5.0 – 18.0	6.0 – 20.0	auto	150	2	017-500866
	RT 8	A	-20 – 12	1.5 – 7.0	1.5 – 7.0	auto	145	2	017-506366
	RT 12	A	-5 – 10	1.0 – 3.5	1.0 – 3.0	auto	65	2	017-508966
	RT 23	A	5 – 22	1.1 – 3.5	1.0 – 3.0	auto	85	2	017-527866
	RT 15	A	8 – 32	1.6 – 8.0	1.6 – 8.0	auto	150	2	017-511566
	RT 24	A	15 – 34	1.4 – 4.0	1.4 – 3.5	auto	105	2	017-528566
	RT 140	C	15 – 45	1.8 – 8.0	2.5 – 11.0	auto	240	2	017-523666
	RT 102	D	25 – 90	2.4 – 10.0	3.5 – 20.0	auto	300	2	017-514766
	RT 34	B	-25 – 15	2.0 – 10.0	2.0 – 12.0	auto	100	–	017-511866
	RT 7	A	-25 – 15	2.0 – 10.0	2.5 – 14.0	auto	150	2	017-505366
	RT 14	A	-5 – 30	2.0 – 8.0	2.0 – 10.0	auto	150	2	017-509966
RT 101	A	25 – 90	2.4 – 10.0	3.5 – 20.0	auto	300	2	017-500366	
Partial ³⁾	RT 107	A	70 – 150	6.0 – 25.0	1.8 – 8.0	auto	215	2	017-513566

1) The sensor must be located colder than thermostat housing and capillary tube.

2) The sensor can be located warmer or colder than thermostat housing.

3) The sensor must be located warmer than thermostat housing and capillary tube.

4) With built-in heating coil – reduces the thermal differential.

Thermostats with adjustable dead zone

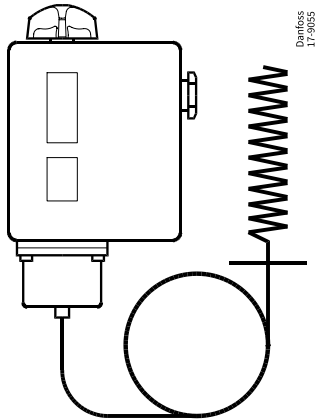

Charge	Type	Bulb type	Regulation range	Mechanical differential	Neutral zone NZ		Max. bulb temp.	Capillary tube length	Code no.
					At min. range setting	At max. range setting			
					[°C]	[K]			
Vapour	RT 16L	B	0 – 38	1.5 – 0.7	1.5 – 5.0	0.7 – 1.9	100	–	017L002466
Adsorption	RT 8L	A	-20 – 12	1.5	1.5 – 4.4	1.5 – 4.9	145	2	017L003066
	RT 14L	A	-5 – 30	1.5	1.5 – 5.0	1.5 – 5.0	150	2	017L003466
	RT 140L	C	15 – 45	1.8 – 2.0	1.8 – 4.5	2.0 – 5.0	240	2	017L003166
	RT 101L	A	25 – 90	2.5 – 3.5	2.5 – 7.0	3.5 – 12.5	300	2	017L006266

Type of bulb / sensor

A	B	C	D
Cylindrical remote sensor	Room sensor	Duct sensor	Capillary tube sensor

Special versions



RT can be supplied with special switches.
See next page.

When ordering, please state:

1. Type
2. Code no. of standard unit
3. Code no. of special switch

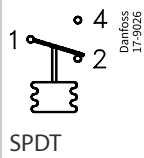
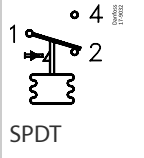
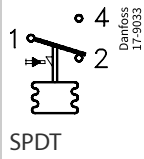
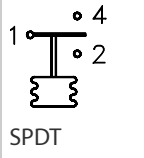
Switches

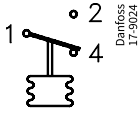
Version	Symbol	Description	Contact rating	Reset	Code no.
Standard	 SPDT	Single-pole changeover switch with terminal board proof against leakage current. Fitted in all standard versions of type RT. Snap action changeover contacts.	Alternating current Ohmic: AC 1 = 10 A, 400 V Inductive: AC 3 = 4 A, 400 V AC 15 = 3 A, 400 V Dir. current: DC 13 = 12 W, 220 V	Auto	017-403066
Man. reset	 SPDT	For manual reset of unit after contact changeover on rising temperature. For units with reset facility.		Max.	017-404266
Man. reset	 SPDT	For manual reset of unit after contact changeover on falling temperature. For units with reset facility.		Min.	017-404166
Neutral zone	 SPDT	Single-pole changeover switch with dead zone and terminal board proof against leakage current.		-	Available only as a component part of RT controls with adjustable neutral zone

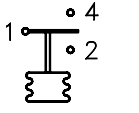
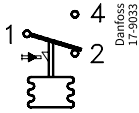
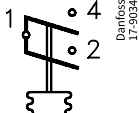
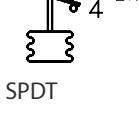
<p>Standard</p>	 <p>SPDT</p>	<p>Single-pole changeover switch with gold plated (oxide-free) contact surfaces.</p> <p>Increases cut-in reliability on alarm and monitoring systems, etc.</p> <p>Snap action changeover contacts.</p> <p>Terminal board proof against leakage current.</p>		<p>Auto</p>	<p>017-424066</p>
<p>Man. reset</p>	 <p>SPDT</p>	<p>Single-pole changeover switch with gold plated (oxide-free) contact surfaces.</p> <p>Increases cut-in reliability on alarm and monitoring systems, etc.</p> <p>Snap action changeover contacts.</p> <p>Terminal board proof against leakage current.</p>	<p>Alternating current</p> <p>Ohmic:</p> <p>AC 1 = 10 A, 400 V</p>	<p>Max</p>	<p>017-404866</p>
<p>Neutral zone</p>	 <p>SPDT</p>	<p>Single-pole changeover switch with dead zone and gold plated (oxide-free) contact surfaces.</p> <p>Increase cut-in reliability on alarm and monitoring systems, etc.</p> <p>Snap action changeover contacts.</p> <p>Terminal board proof against leakage current.</p>	<p>Inductive:</p> <p>AC 3 = 2 A, 400 V</p> <p>AC 15 = 1 A, 400 V</p> <p>Dir. current:</p> <p>DC 13 = 12 W, 220 V</p>	<p>-</p>	<p>Available only as a component part of RT controls with adjustable neutral zone</p>
<p>Man. reset</p>	 <p>SPDT</p>	<p>Single-pole changeover switch with gold plated (oxide-free) contact surfaces.</p> <p>Increases cut-in reliability on alarm and monitoring systems, etc.</p> <p>Snap action changeover contacts.</p> <p>Terminal board proof against leakage current.</p>		<p>Min.</p>	<p>017-404766</p>
<p>Cuts in two circuits simultaneously</p>	 <p>SPST</p>	<p>Single-pole changeover switch that cuts in two circuits simultaneously on rising temperature.</p> <p>Snap action changeover contacts.</p> <p>Terminal board proof against leakage current.</p>	<p>Alternating current</p> <p>Ohmic:</p> <p>AC 1 = 10 A, 400 V</p> <p>Inductive:</p> <p>AC 3 = 3 A, 400 V</p> <p>AC 15 = 2 A, 400 V</p> <p>Dir. current:</p> <p>DC 13 = 12 W, 220 V ¹⁾</p>	<p>Max</p>	<p>017-403466</p>
<p>With non-snap action change-over contacts</p>	 <p>SPDT</p>	<p>Single-pole changeover switch with non-snap action changeover contacts.</p>	<p>Alternating or direct current</p> <p>25 VA, 24 V</p>	<p>-</p>	<p>017-018166</p>

¹⁾ If current is led through contacts 2 – 4, i.e. terminals 2 – 4 connected but not 1, max. permissible load is increased to 90 W, 220 V.

The switches are shown in the position they assume on falling temperature, i.e. after downward movement of the RT main spindle. The setting pointer of the control shows the scale value at which contact changeover occurs on falling temperature.

Product details

General data

Table: Technical data

Cable connection	Pg 13.5. Cable diameter 6 – 14 mm.
Enclosure	IP66 acc. to EN 60529 / IEC 60529, except for versions with ext. reset which are IP54.
Permissible ambient temperature	-50 – 70 °C for thermostat housing.
Switches	See "Ordering switches"

Properties according to EN 60947

Wire dimensions	
Solid / stranded	0.2 – 2.5 mm ²
Flexible, w/out ferrules	0.2 – 2.5 mm ²
Flexible, with ferrules	0.2 – 1.5 mm ²
Tightening torque	max. 1.5 Nm
Rated impulse voltage	4 kV
Pollution degree	3
Short circuit protection, fuse	10 A
Insulation	400 V
Ingress protection	IP54, IP66

Charges

1. Vapour charge

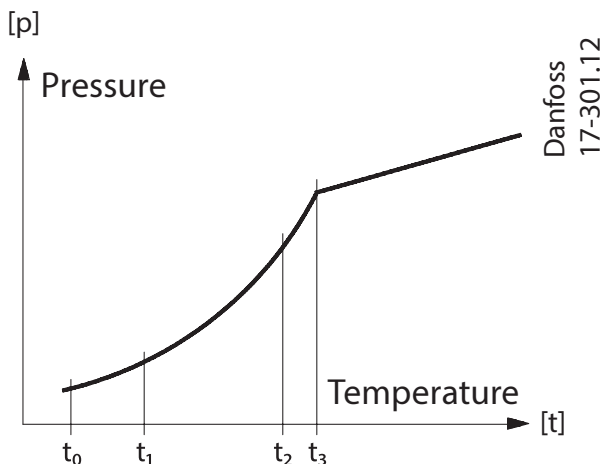

Here the interdependence between the pressure and temperature of saturated vapour is utilized, i.e. the element is charged with saturated vapour plus a small amount of liquid.

The charge is pressure-limited; a further increase in pressure after evaporation of all the liquid in the bulb, will only result in a small pressure increase in the element.

This principle can be utilized in thermostats for low temperature, etc., where evaporation must be able to take place from the free liquid surface in the bulb (within the operation range of the thermostat), and where at the same time, the bellows must be protected against deformation when kept at normal ambient temperatures. Since the pressure in the element depends on the temperature at the free liquid surface, the thermostat must always be placed so that the bulb is colder than the rest of the thermostatic element.

The evaporated liquid will recondense at the coldest point, i.e. the bulb. Thus, as intended, the bulb becomes the temperature-controlling element in the system.

Note: When the bulb is coldest, the ambient temperature has no effect on regulating accuracy.

2. Adsorption charge

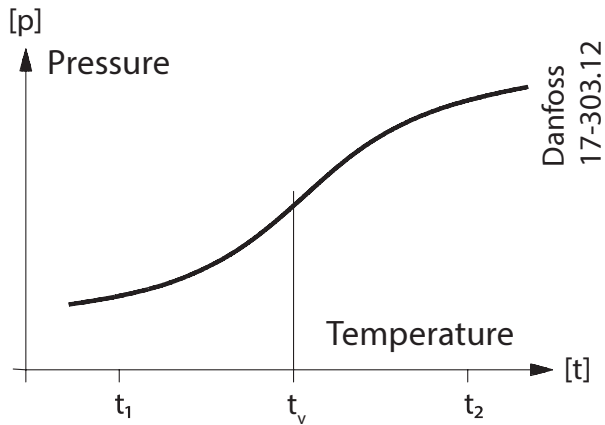

In this case the charge consists partly of a superheated gas and partly of a solid having a large adsorption surface.

The solid is concentrated in the bulb and it is therefore always the bulb that is the temperature-controlling part of the thermostatic element.

The bulb can thus be placed warmer or colder than the rest of the thermostatic element. Such a charge is however to some extent sensitive to changes in the temperature of the bellows element and capillary tube.

Under normal conditions this is not important, but if the thermostat is used in extreme conditions, scale deviation will occur.

The scale can be corrected by using the graph and the table.

Scale correction = $Z \times a$.

Z can be found in the graph and "a" in the table.

Scale deviation factor

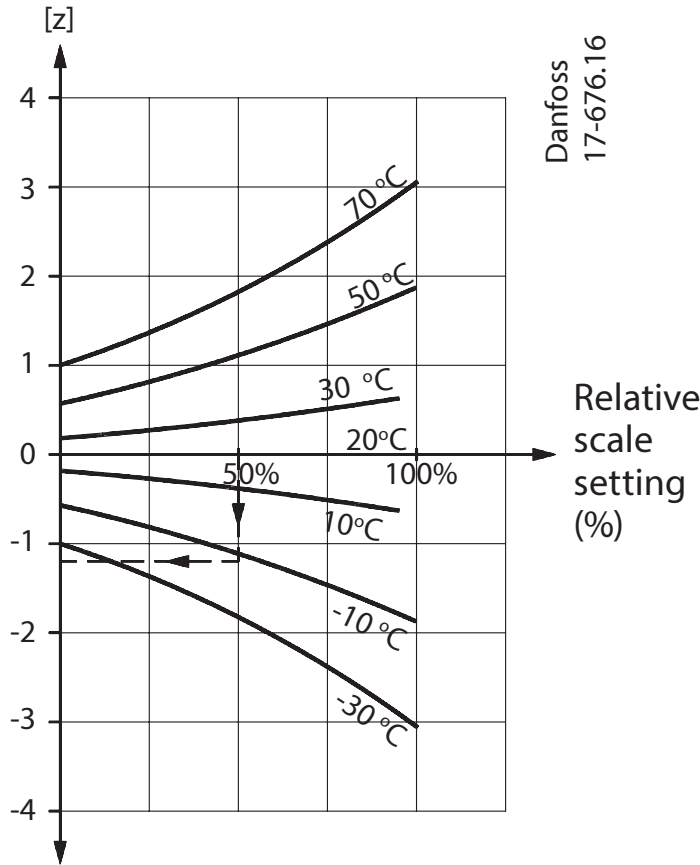

Curves for different ambient temperatures.
 0% ~ lowest scale setting temperature
 100% ~ highest scale setting temperature.

Type	Range [°C]	Correction factor "a"
RT 2	-25 – 15	2.3
RT 7	-25 – 15	2.9
RT 8, RT 8L	-20 – 12	1.7
RT 12	-5 – 10	1.2
RT 14, RT 14L	-5 – 30	2.4
RT 15	8 – 32	1.2
RT 23	5 – 22	0.6
RT 24	15 – 34	0.8
RT 101, RT 102	25 – 90	5.0
RT 140, RT 140L	15 – 45	3.1

Example

Scale correction on an RT 14 (range -5 – 30 °C) at activating temperature 12 °C and ambient temperature -10 °C. The scale temperature, 12 °C, lies approximately in the middle of the scale range, i.e. relative scale setting of 50%. The factor Z can be found in the graph from 50% and the curve for -10 °C, i.e. approx. -1.2.

The correction factor "a" can be found in the table for an RT 14, i.e. 2.4.

The scale correction = $Z \times a = -1.2 \times 2.4 = -2.88$. If activation at 12 °C for the same conditions is required, the thermostat must be set at $12 \times 2.88 = 9.12 \approx 9.1$.

3. Partial charge

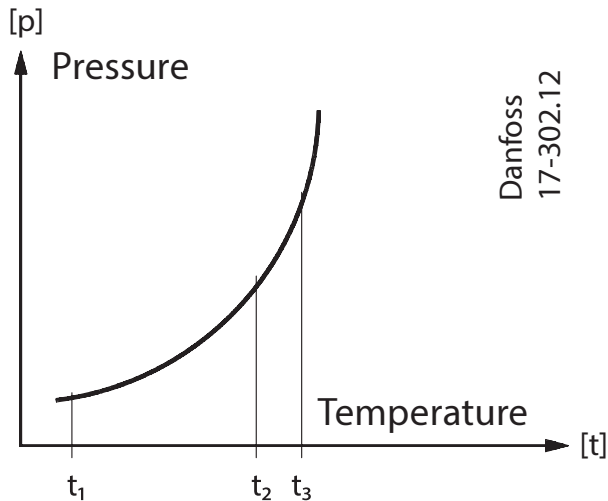

Partial charge is used in RT units having a range lying higher than ambient temperature. As with the vapour charge, the partial charge utilizes the interdependence between the pressure and temperature of saturated vapour.

The partial charge is of such a volume that the bellows housing, capillary tube and a small part of the bulb are filled when the thermostat is in operation. The bulb is thus the warmest part of the system.

The liquid will condense in the remaining, coldest, part of the system but because of the volume of the charge the free liquid surface will always be in the bulb. In this way, the bulb becomes the temperature-controlling part of the system.

Note: When the bulb is placed warmest, the ambient temperature has no effect on regulating accuracy.

Setting of differential

The knob can be used to make a setting on the range scale for the lowest temperature at which the contact system must be activated (cut-out or cut-in).

The differential roller 19 must then be used to set the differential. The highest activating temperature at the sensor is equal to the activating temperature + the set differential.

Nomograms for obtained differentials

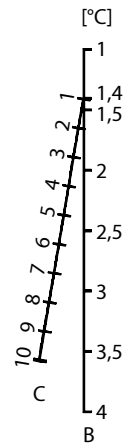
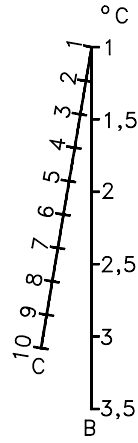
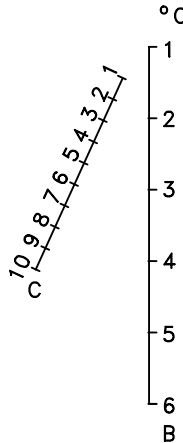
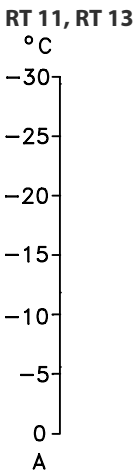
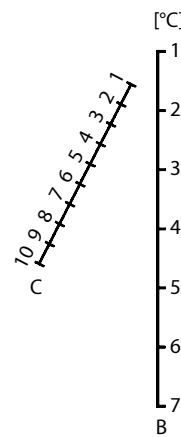
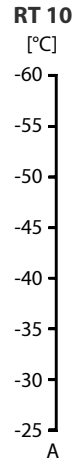
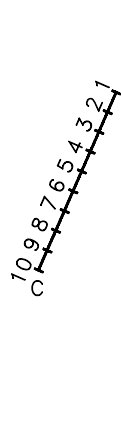
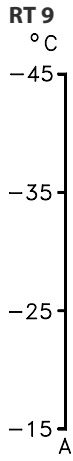
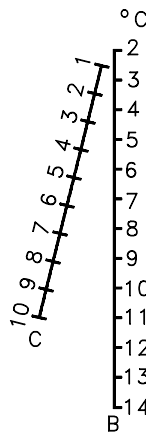
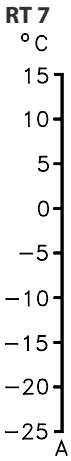
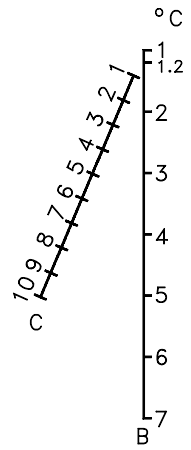
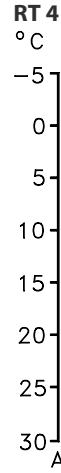
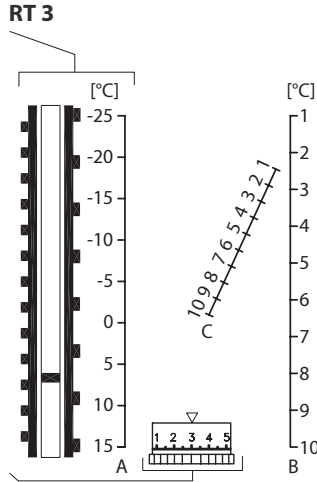
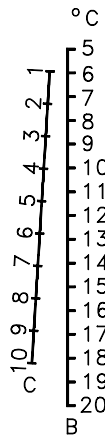
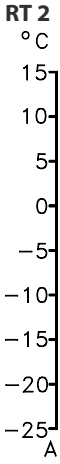

A = Range setting
B = Obtained differential
C = Differential setting



RT 14

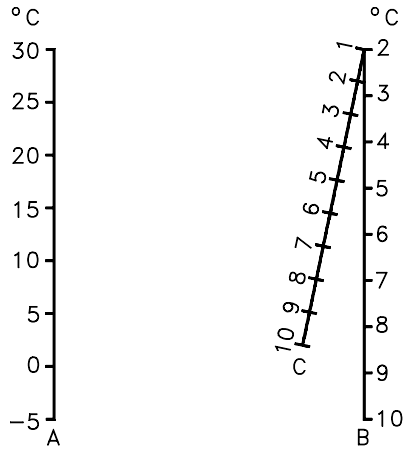

RT 17

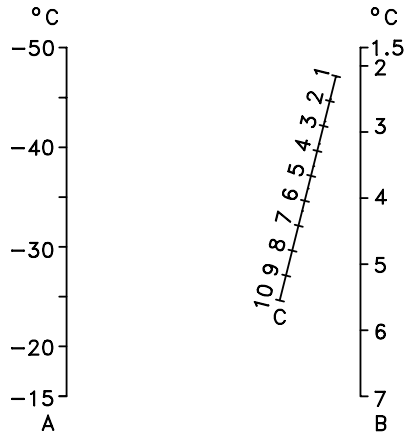

RT 23

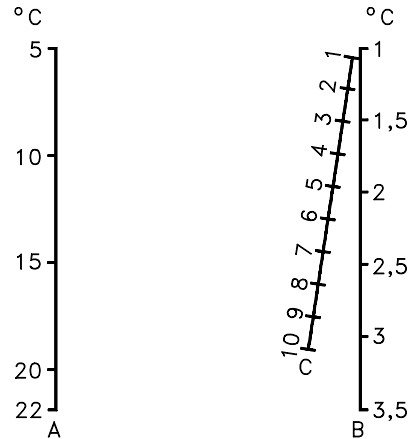

RT 34

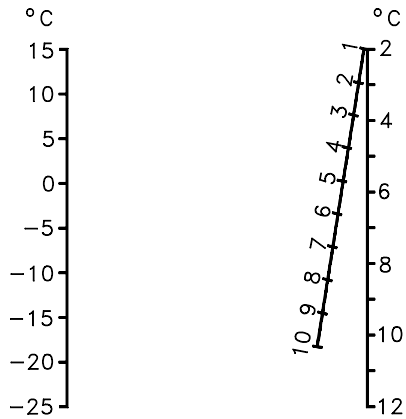

RT 101

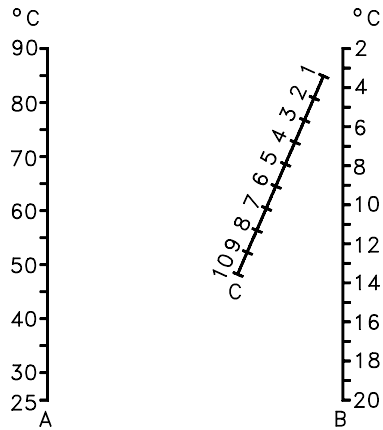

RT 107

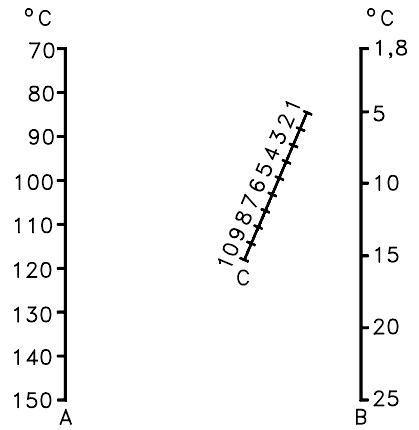

RT 140

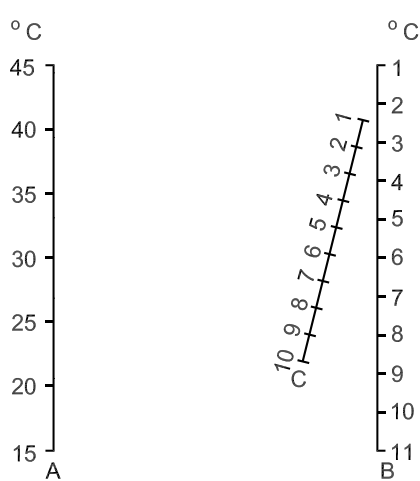

A = Range setting
 B = Obtained differential
 C = Differential setting

Design

Design / Function

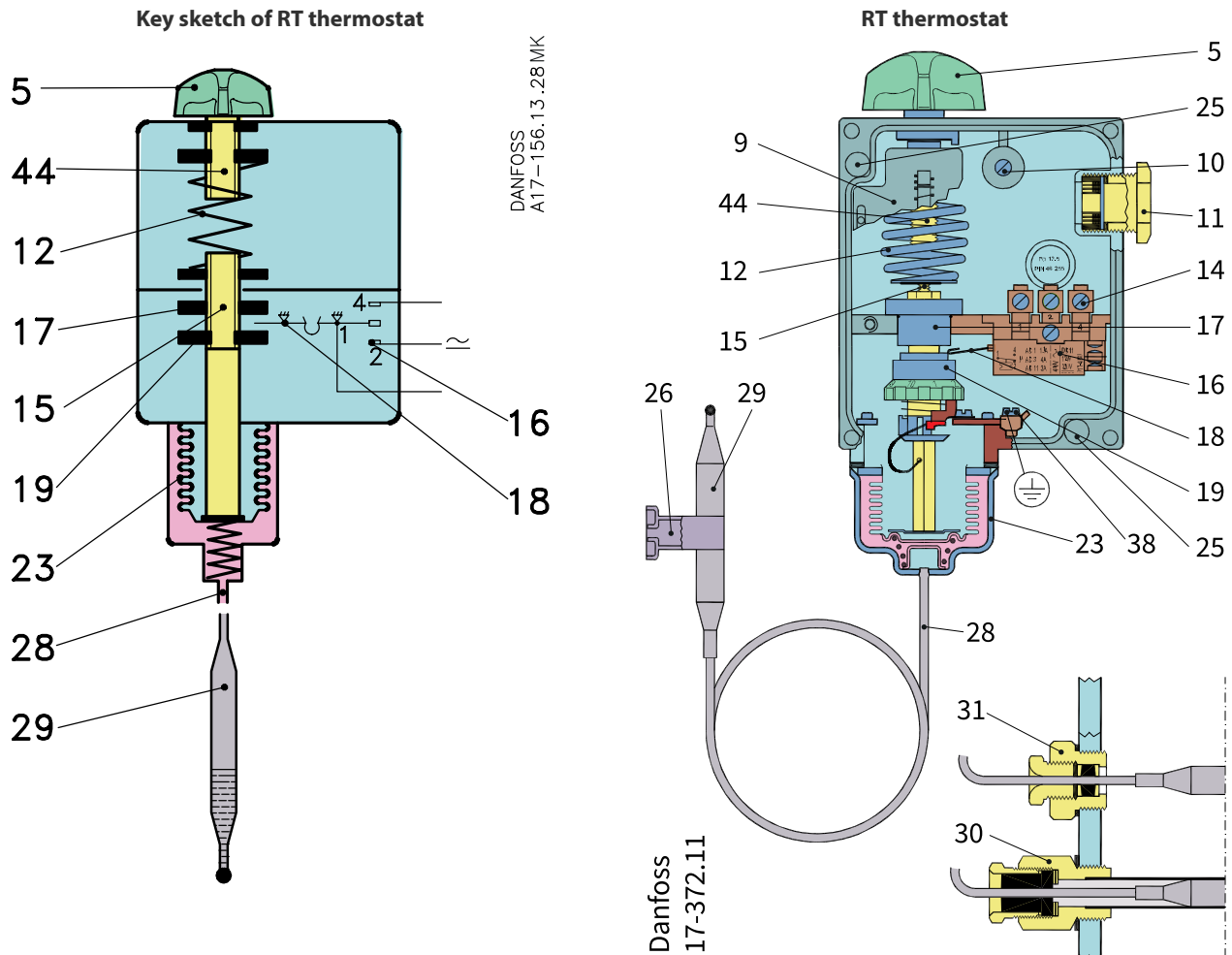

5.	Setting knob	19.	Differential temperature setting nut
9.	Regulation range scale	23.	Bellows element
10.	Loop terminal	25.	Fixing hole
11.	Pg 13.5 screwed cable entry	26.	Sensor (bulb) clip
12.	Main spring	28.	Capillary tube
14.	Terminals	29.	Sensor (bulb)
15.	Main spindle	30.	Sensor (bulb) pocket
16.	Switch	31.	Capillary tube gland
17.	Upper guide bush	38.	Earth terminal
18.	Contact arm	44.	Temperature setting spindle

The thermostatic element consists of a sensor (29) capillary tube (28) and bellows element (23). The element contains a charge that reacts to temperature variations at the sensor so that the pressure on the moving bellows rises when temperature rises.

By turning the setting knob (5) the main spring (12) can be set to balance the pressure in the element.

A rise in temperature at the sensor compresses the bellows and moves the main spindle (15) upwards until spring force and element pressure are in equilibrium.

The main spindle (15) is fitted with a guide bush (17) and a differential setting nut (19) that together transfer the main spindle movement to the switch (16).

Key sketch RT L thermostat with neutral zone

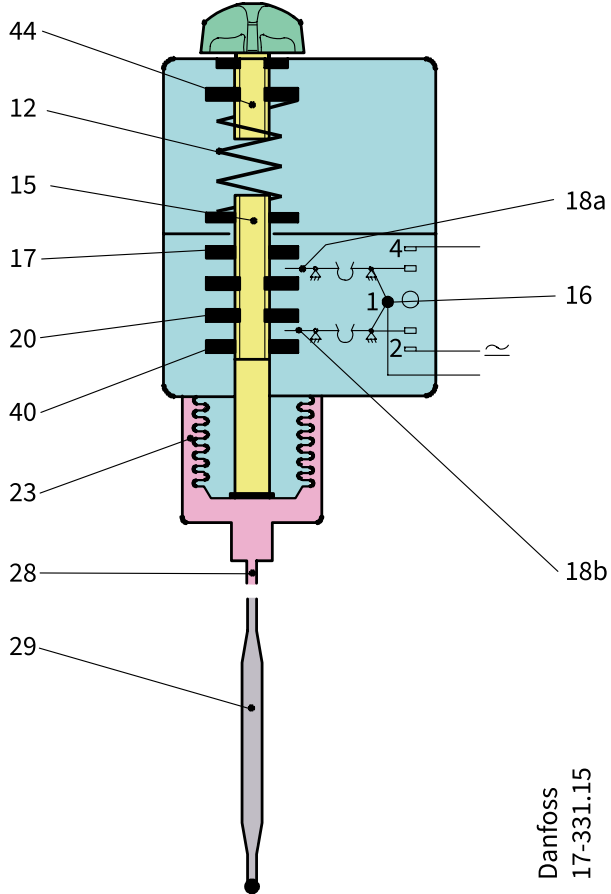

RT L thermostat with neutral zone

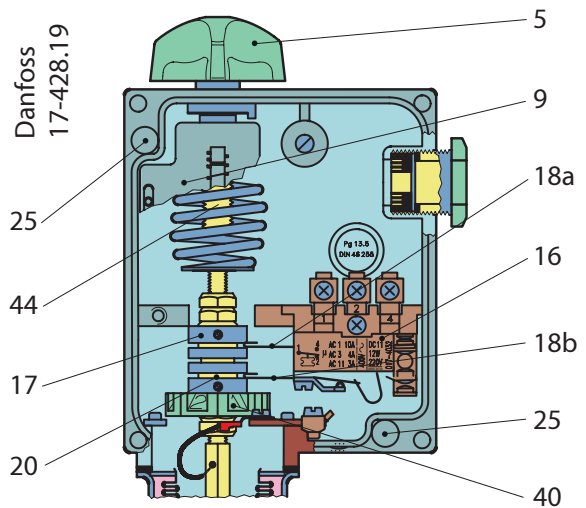

5.	Setting knob	20.	Lower guide bush
9.	Regulation range scale	23.	Bellows element
12.	Main spring	25.	Fixing hole
15.	Main spindle	28.	Capillary tube
16.	Switch	29.	Sensor (bulb)
17.	Upper guide bush	40.	Neutral zone setting nut
18a	Contact arm	44.	Temperature setting spindle
18b.	Contact arm		

RT L thermostats are fitted with a switch with an adjustable neutral zone. This enables the units to be used for floating control. The neutral zone switch contact arms (18a) and (18b) are operated by the spindle guide bushes (17) and (20).

The upper guide bush (17) is fixed while the lower guide bush (20) can be moved up or down by the setting nut (40). In this way the neutral zone can be varied between a minimum value (equal to the mechanical differential of the unit) and a maximum value (depending on the type of RT unit).

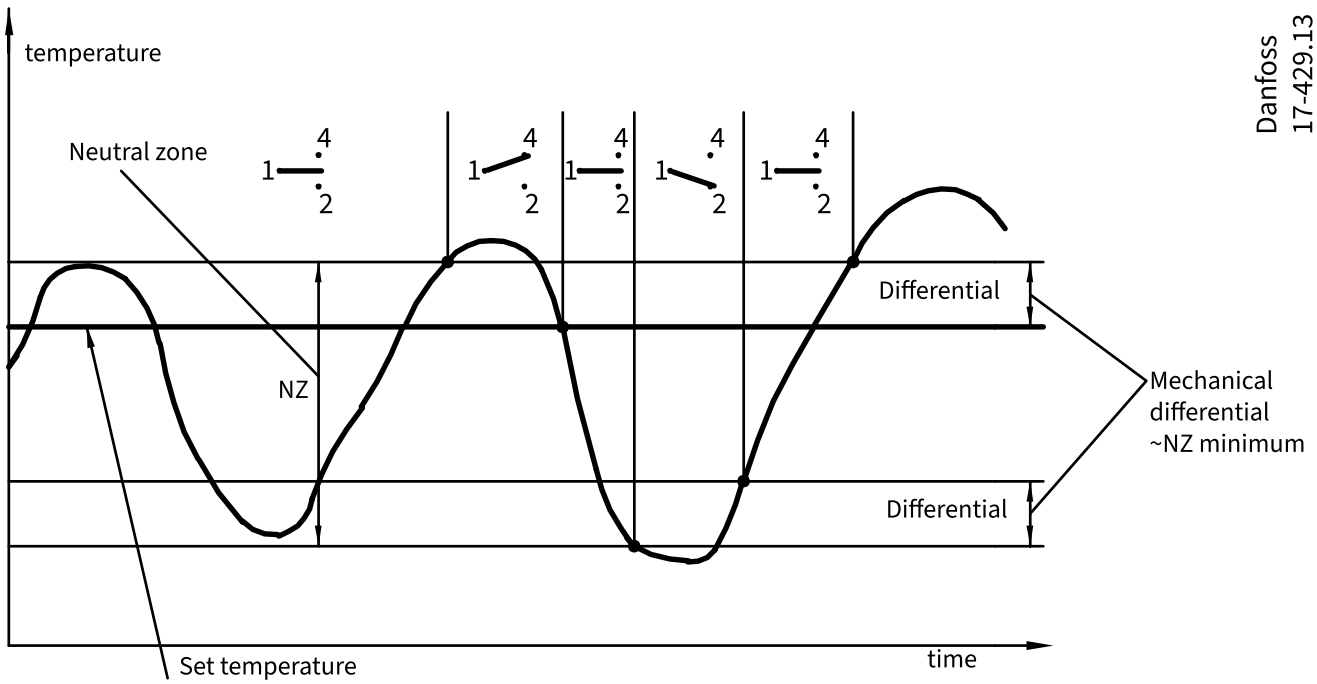

Terminology

Floating control

A form of delayed control where the correcting element (e.g. valve, damper, or similar) moves towards one extreme position at a rate independent of the magnitude of the error when the error exceeds a definite positive value, and towards the opposite extreme position when the error exceeds a definite negative value.

Hunting

Periodic variations of the controlled variable from the fixed reference.

Neutral zone

The interval between the make points of the two contacts.

RT differential thermostat

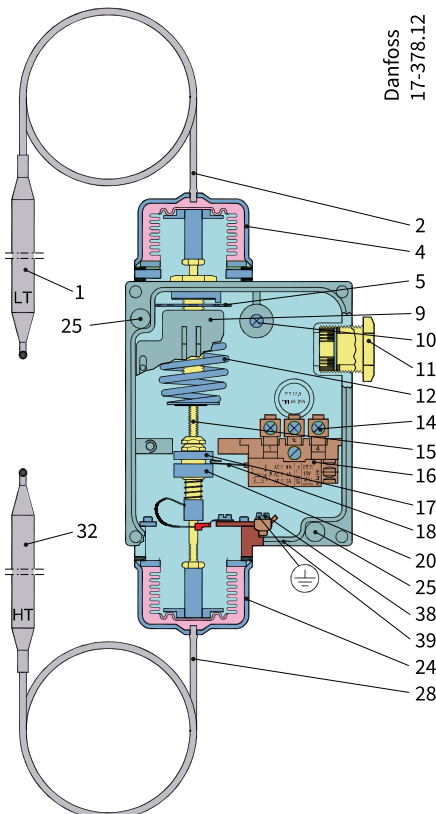

1.	LT sensor (bulb)	16.	Switch
2.	Capillary tube	17.	Upper guide bush
4.	LT bellows element	18.	Contact arm
5.	Setting disc	20.	Lower guide bush
9.	Regulation range scale	24.	HT bellows element
10.	Loop terminal	25.	Fixing hole
11.	Pg 13.5 screwed cable entry	28.	Capillary tube
12.	Main spring	32.	HT sensor (bulb)
14.	Terminals	38.	Earth terminal
15.	Main spindle	39.	Blow-out disc

An RT differential thermostat contains a single-pole changeover switch that makes or breaks depending on the temperature difference between the two sensors of the unit.

The RT 270 017D003166 is for use in process plant, ventilation plant, and refrigeration and heating plant where there is need to maintain a certain temperature differential, 0 – 15 °C, between two media. One sensor is used as a reference and the other as a control sensor. The temperature differential is the direct controlled variable.

The figure shows a cross-section of the RT 270.

The differential thermostat contains two bellows elements: the LT element whose sensor must be placed in the medium having the lowest temperature, and the HT element whose sensor must be placed in the medium having the highest temperature.

The main spring has a rectilinear characteristic.

Within the operating range the RT 270 can be set for different temperature differentials by the setting disc (5).

When the differential between LT and HT sensor temperature falls, the main spindle (15) moves downwards.

The contact arm (18) is moved downwards by the guide (17) so that contacts (1 – 4) break and contacts (1 – 2) make when the set temperature differential is reached.

The contacts changeover again when the temperature differential rises to the set value plus the fixed contact differential of approx. 2 °C.

Example

Set differential = 4 °C.

Switch breaks at 4 °C differential and remakes at $4 + 2 = 6$ °C.

Terminology

Regulation range

The temperature differential between LT and HT sensors within which the unit can be set to operate. Indicated on the thermostat scale.

Scale indication

The difference between the temperature on LT and HT sensors at the moment when the switch contacts change over as a result of the downward movement of the spindle.

Operating range

The temperature range of the LT sensor, within which the differential thermostat can operate.

Contact differential

The temperature rise on the HT sensor over the set temperature differential which causes the switch contacts to make or break.

Reference sensor

The sensor that is placed in the medium whose temperature is not affected by the function of the thermostat (HT or LT sensor).

Control sensor

The sensor that is placed in the medium whose temperature must be controlled (LT or HT sensor).

Dimensions

RT thermostat housing

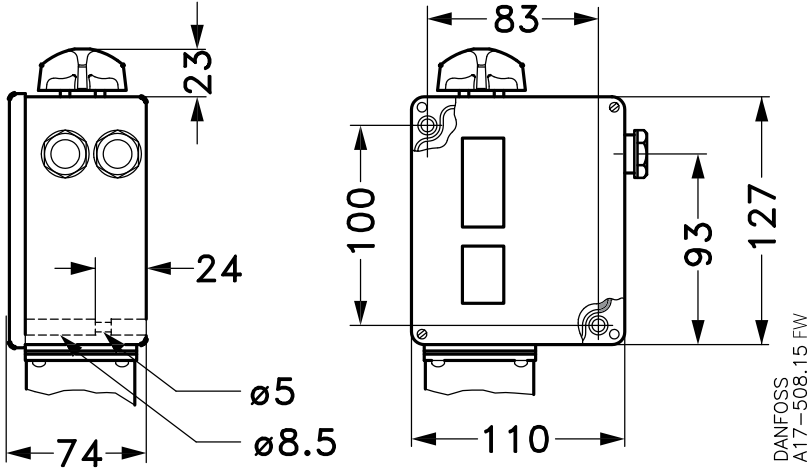

RT 4, RT 11, RT 16L, RT 17, RT 34

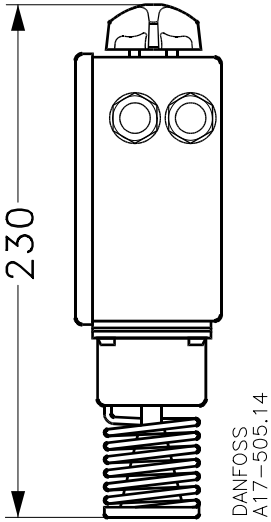

RT thermostat housing

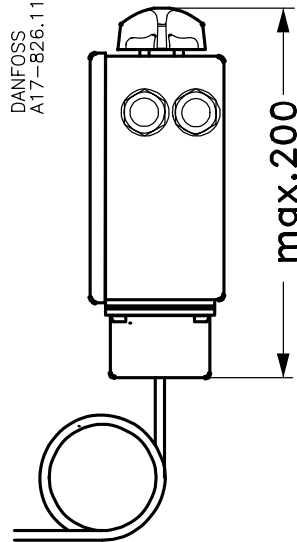

RT 140, RT 140L

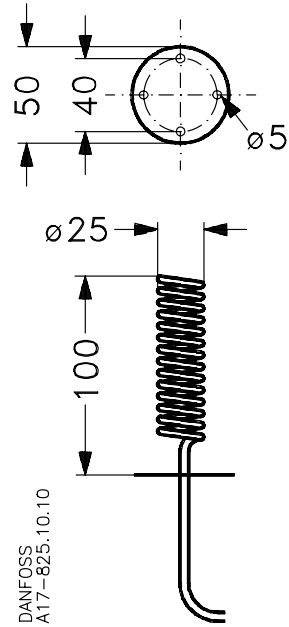

RT 2, RT 3, RT 7, RT 9, RT 13, RT 101

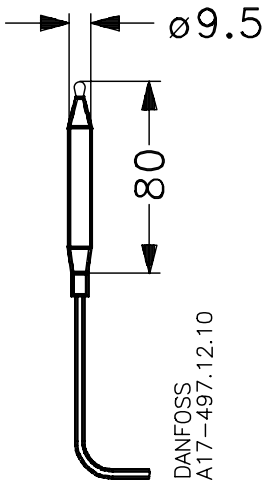

RT 8, RT 8L, RT 14, RT 14L, RT 15, RT 107, RT 270

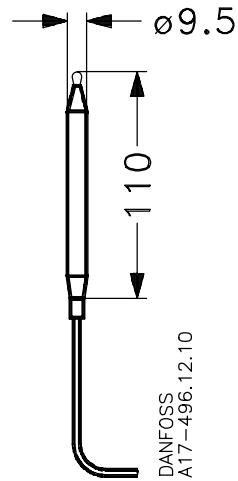

RT 12, RT 23, RT 24

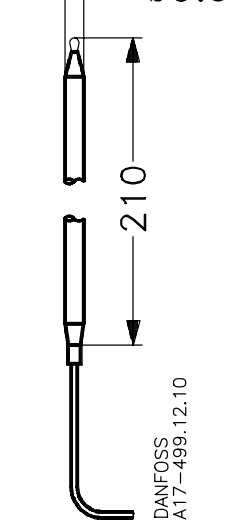

RT 102

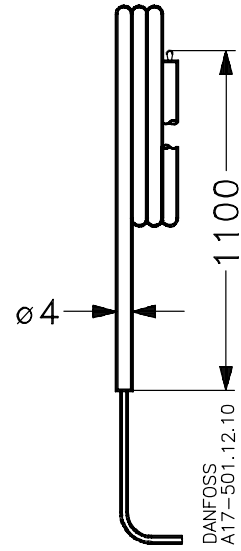

Certificates, declarations and approvals

The list contains all certificates, declarations, and approvals for this product type. Individual code number may have some or all of these approvals, and certain local approvals may not appear on the list.

When you click on the link you will be directed to the latest version of the 'Declaration of Conformity'. Products developed and sold before this date of issue conform to the directives/standards in force at the time of their sale.

Approval type	Title	Certification body	Approval topic
CCC Declaration	Danfoss CCC 2024010305641306	CCC - China Compulsory Certification	CCC
Manufacturer's Declaration	Danfoss MD 060-9639.AB	Danfoss	China RoHS
EU Declaration	Danfoss EU 060-9650AF	Danfoss	LVD, EU RoHS
Electrical Safety Certificate	EAC KZ 7100841.01.01.01391	EAC - Eurasian Customs Union	EMC
Export Control Declaration	Pressure switches & Thermostats	Danfoss	
Marine Certificate	DNV TAA000015E Rev. 1	DNV GL	Marine
Marine Certificate	RINA ELE290325XG	RINA - Registro Italiano Navale	
UA Declaration	Danfoss UA 2024-07-25 cooling sensors	Danfoss	EMC, LVD
Pressure Safety Certificate	LLC CDC EURO-TYSK UA.TR.089.1015.05-22	LLC CDC EURO TYSK - Ukraine	Pressure
Marine Certificate	NKK TA24041M	ClassNK - The Japanese Marine Association	Marine
UA Declaration	Danfoss UA 2023-01-10 Regulators PL01 PL04	Danfoss	PED, Pressure
Marine Certificate	DNV TAA00000Y8 Rev. 1	DNV GL	
Marine Certificate	KR HMB 17529-AE004	KR - Korean Register of Shipping	Marine
Marine Certificate	LR21366305TA	LR - Lloyd's Register	
Marine Certificate	BV 07682-F0 BV	BV - Bureau Veritas	

Contact details

Online support

Danfoss offers a wide range of support along with our products, including digital information, software, mobile apps and expert guidance. See the possibilities below.



The Danfoss Design center

Discover the Design Center, our advanced digital platform that streamlines product selection. With integrated tools and enhanced type pages, it's simpler than ever to access product information and documentation, and to select the right products. Check the availability of Danfoss products at partner locations and enjoy seamless transitions from selection to purchase with our basket-to-basket functionality. Whether you're buying from our distributors or directly from the Product Store, the Design Center simplifies your experience. Learn more at: designcenter.danfoss.com.



The Danfoss product store

The Danfoss Product Store is a one-stop shop available 24/7 for our customers, no matter where you are in the world or what area of industry you work in. Browse our catalog, check product details and documentation, view your prices and product availability, and quickly finalize your purchase. Start browsing at: store.danfoss.com.



Danfoss Partner Portal/Product Data tool

Designed to support you with easy access to product data extracts, essential resources, tools, and information. The Partner Portal provides a centralized hub for product documentation, training materials, marketing assets, and technical support, ensuring you have everything you need to succeed and grow your business with Danfoss. The Partner Portal is available 24/7 at: partner.danfoss.com and is ready to support your business.



Find technical documentation

Find technical documentation you need to get your project up running. Get direct access to our official collection of data sheets, certificates and declarations, manuals and guides, 3D models and drawings, case stories, brochures, and much more. Start searching now at: documentation.danfoss.com.



Danfoss Learning

Danfoss Learning is a free online learning platform. It features courses and materials specifically designed to help engineers, installers, service technicians, and wholesalers better understand the products, applications industry topics, and trends that will help you do your job better. Find your local Danfoss website here: learning.danfoss.com.



Get local information and support

Local Danfoss websites are the main sources for help and information about our company and products. Find product availability, get the latest regional news, or connect with a nearby expert - all in your own language. Find your local Danfoss website here: danfoss.com.

Danfoss A/S

Climate Solutions . danfoss.com . +45 7488 2222

Any information, including, but not limited to information on selection of product, its application or use, product design, weight, dimensions, capacity or any other technical data in product manuals, catalogues description, advertisements, etc. and whether made available in writing, orally, electronically, online or via download, shall be considered informative, and is only binding if and to the extent, explicit reference is made in a quotation or order confirmation. Danfoss cannot accept any responsibility for possible errors in catalogues, brochures, videos and other material. Danfoss reserves the right to alter its products without notice. This also applies to products ordered but not delivered provided that such alterations can be made without changes to form, fit or function of the products. All trademarks in this material are property of Danfoss A/S or Danfoss group companies. Danfoss and the Danfoss logo are trademarks of Danfoss A/S. All rights reserved.
