



Solenoid valve

EVR 2 - EVR 40

Description

EVR[®] is a direct or servo operated solenoid valve suitable for liquid, suction, and hot gas lines with most refrigerants, including flammable refrigerants.

EVR[®] valves and coils are sold separately.

Features & benefits

- Complete range of solenoid valves for refrigeration, freezing and air conditioning plant
- Supplied in versions normally closed (NC) and normally open (NO) with de-energized coil
- Wide choice of coils for AC and DC
- Suitable for most refrigerants, including flammable refrigerants
- Designed for media temperatures up to 105°C (221°F)
- Flare connections up to 5/8 in
- Solder connections up to 2 1/8 in
- Extended ends on solder versions make the installation easy
- Available in flare, solder and flange connection versions
- Bi-directional solenoid valves EVRC with built-in check valve

Ordering

Product code numbers

Ordering EVR solder connection, Normally Closed (NC) - separate valve bodies

<p>Figure: EVR 2 / EVR 3</p> 	<p>Figure: EVR 4 / EVR 6 / EVR 8</p> 	<p>Figure: EVR 10</p> 
<p>Figure: EVR 15 / EVR 18 / EVR 20 / EVR 22</p> <p>Danfoss 032F7325</p> 	<p>Figure: EVR 25</p> <p>Danfoss 032F7342</p> 	<p>Figure: EVR 32 / EVR 40</p> <p>Danfoss 032F7349</p> 

Table: EVR solder - NC

Type	Coil voltage	Connection size		Manual operation	K _v value	Code no.
		[in]	[mm]		[m ³ /h]	
EVR 2	AC / DC	¼	–	No	0.15	032F1201
	AC / DC	¼	–	No	0.15	032F7100
	AC / DC	–	6	No	0.15	032F1202
EVR 3	AC / DC	¼	–	No	0.26	032F1206
	AC / DC	⅜	–	No	0.26	032F1204
	AC / DC	–	6	No	0.26	032F1207
	AC / DC	–	10	No	0.26	032F1208
EVR 4	AC / DC	⅜	–	No	0.7	032L7110
EVR 6	AC / DC	⅜	–	No	1	032L1212
	AC / DC	⅜	–	Yes	0.87	032L7116
	AC / DC	–	10	No	1	032L1213
	AC / DC	–	12	No	1	032L1236
	AC / DC	½	–	No	1	032L1209
	AC / DC	½	–	Yes	0.87	032L7144
	AC / DC	⅝	–	No	1	032L7117
EVR 8	AC / DC	½	–	No	1.15	032L7121
	AC / DC	½	–	Yes	1.09	032L7148
	AC / DC	⅝	–	No	1.15	032L7122
EVR 10	AC / DC	⅜	–	No	1.56	032L7125
	AC / DC	–	12	No	2.2	032L1218
	AC / DC	½	–	No	2.2	032L1217
	AC / DC	½	–	Yes	2.2	032L1188
	AC / DC	⅝	16	No	2.2	032L1214
	AC / DC	⅝	–	Yes	2.2	032L7149
EVR 15	AC / DC	⅝	16	No	3.3	032L1228
	AC / DC	⅝	16	Yes	3.3	032L1227
	AC / DC	⅞	22	No	3.3	032L1225
EVR 18	AC / DC	⅞	–	Yes	3.9	032L1004
EVR 20	AC / DC	⅞	–	No	6	032L1240
	AC / DC	⅞	–	Yes	6	032L1254
	AC / DC	1 ⅛	–	No	6	032L1244
	AC / DC	–	28	No	6	032L1245
EVR 22	AC / DC	1 ⅛	–	No	6.2	032L7145
	AC / DC	1 ⅛	–	Yes	6.2	032L7137
	AC / DC	1 ⅜	–	No	6.2	032L3267
EVR 25	AC / DC	1 ⅛	–	Yes	9.8	032L2200
	AC / DC	1 ⅛	–	No	9.8	032L2201
	AC / DC	–	28	Yes	9.8	032L2205
	AC / DC	–	28	No	9.8	032L2206
	AC / DC	1 ⅜	–	Yes	9.8	032L2207
	AC / DC	1 ⅜	–	No	9.8	032L2208

EVR 32	AC / DC	1 $\frac{3}{8}$	35	Yes	16.7	032L1105
	AC / DC	1 $\frac{3}{8}$	35	No	16.7	032L1106
	AC / DC	1 $\frac{5}{8}$	–	Yes	16.7	032L1103
	AC / DC	1 $\frac{5}{8}$	–	No	16.7	032L1104
	AC / DC	–	42	Yes	16.7	032L1107
	AC / DC	–	42	No	16.7	032L1108
	AC / DC	2 $\frac{1}{8}$	–	No	16.7	032L1180
	AC / DC	2 $\frac{1}{8}$	–	Yes	16.7	032L1181
EVR 40	AC / DC	1 $\frac{5}{8}$	–	Yes	24.2	032L1109
	AC / DC	1 $\frac{5}{8}$	–	No	24.2	032L1110
	AC / DC	–	42	Yes	24.2	032L1113
	AC / DC	–	42	No	24.2	032L1114
	AC / DC	2 $\frac{1}{8}$	–	Yes	24.2	032L1111
	AC / DC	2 $\frac{1}{8}$	–	No	24.2	032L1112

Ordering EVR solder connection, Normally Open (NO) - separate valve bodies

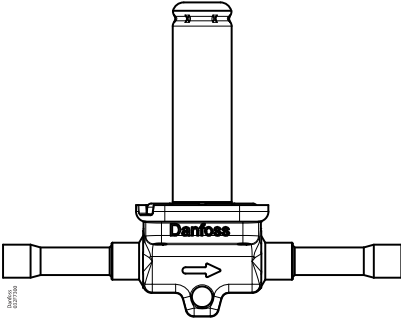
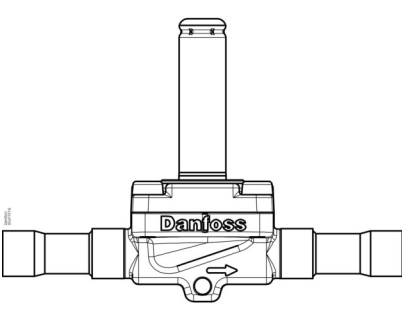
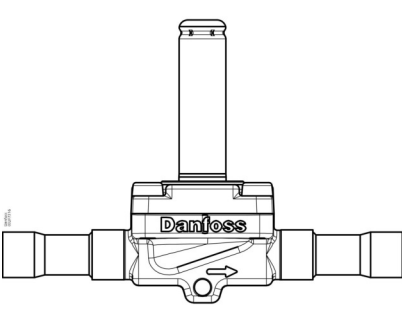
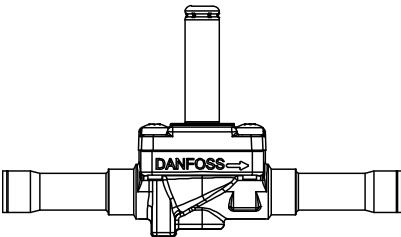
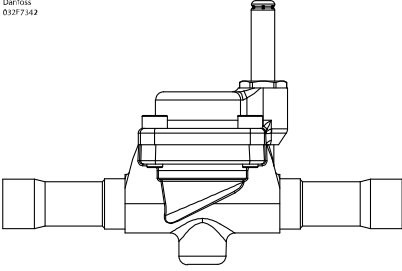
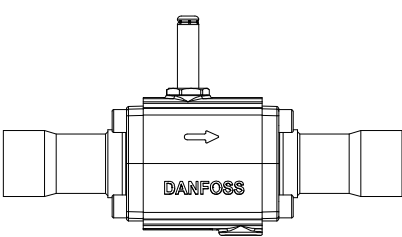
Figure: EVR 6 solder connection (NO)

Danfoss
032F73071

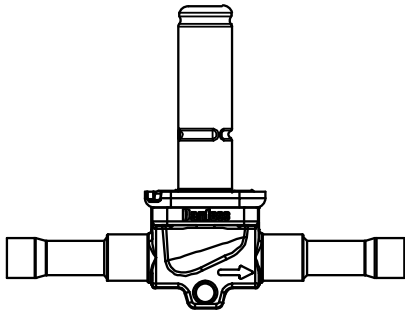

Table: EVR solder - NO

Type	Coil voltage	Connection size		Manual operation	K _v value	Code no.
		[in]	[mm]		[m ³ /h]	
EVR 6	AC / DC	3/8	–	No	1	032L1290
	AC / DC	–	10	No	1	032L1295
EVR 10	AC / DC	1/2	–	No	2.2	032L1291
	AC / DC	–	12	No	2.2	032L1296
EVR 15	AC / DC	5/8	16	No	3.3	032L1299
	AC / DC	7/8	–	No	3.3	032L3270
EVR 20	AC / DC	7/8	–	No	6	032L1260
	AC / DC	1 1/8	–	No	6	032L1269
	AC / DC	–	28	No	6	032L1279
EVR 22	AC	1 3/8	–	No	6	032L3268

Ordering EVR flare connection, Normally Closed (NC) - separate valve bodies

Figure: EVR 6 flare connection (NC)

Danfoss
032F73072

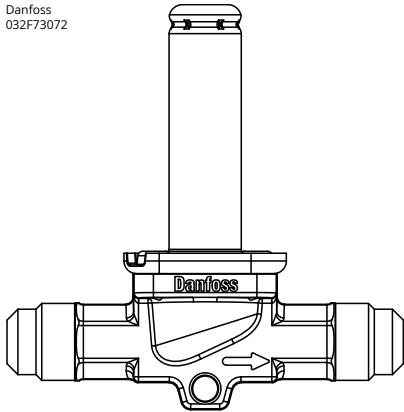

Table: EVR flare - NC

Type	Coil voltage	Connection size		Manual operation	K _v value	Code no.
		[in]	[mm]		[m ³ /h]	
EVR 2	AC / DC	1/4	6	No	1	032F8056
EVR 3	AC / DC	1/4	6	No	1	032F8107
	AC / DC	3/8	10	No	2.2	032F8116
EVR 6	AC / DC	3/8	10	No	2.2	032L8072
	AC / DC	1/2	12	No	3.3	032L8079
EVR 10	AC / DC	1/2	12	No	2.2	032L8095
	AC / DC	5/8	16	No	3.3	032L8098
EVR 15	AC / DC	5/8	16	Yes	3.3	032L8100
	AC / DC	5/8	16	No	3.3	032L8101

Ordering EVR flare connection, Normally Closed (NO) - separate valve bodies

Figure: EVR 6 flare connection (NO)

Danfoss
032F73073

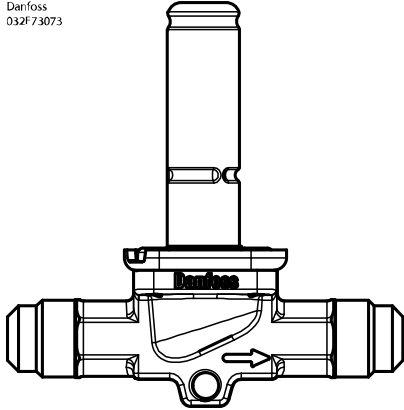

Table: EVR flare - NO

Type	Coil voltage	Connection size		Manual operation	K _v value	Code no.
		[in]	[mm]		[m ³ /h]	
EVR 6	AC / DC	3/8	10	No	1	032L8085
EVR 10	AC / DC	1/2	12	No	2.2	032L8090

Ordering EVRC solder connection, Normally Closed (NC) - separate valve bodies

Figure: EVRC solder connection (NC)

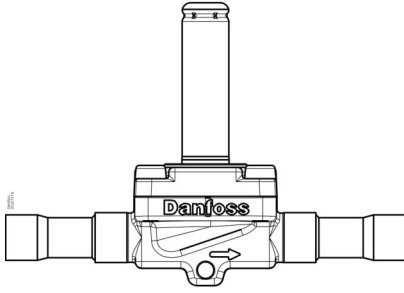

Table: EVRC solder - NC

Type	Coil voltage	Connection size [in]	Connection size [mm]	Manual operation	K _v value [m ³ /h]		Code no.
					Flow in arrow direction	Flow against arrow direction	
EVRC 6	AC / DC	3/8	10	No	0.9	0.64	032L1272
EVRC 15	AC / DC	5/8	16	No	2.7	2.5	032L1255
EVRC 20	AC / DC	7/8	22	No	3.6	5	032L1258

Ordering EVR flange connection, Normally Closed (NC) - separate valve bodies

Figure: EVR 15 flange connection

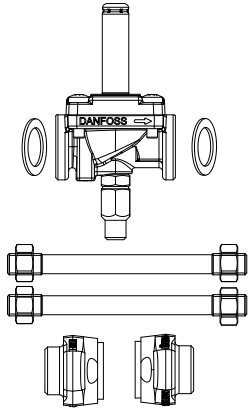

Table: EVR flange

Type	Coil voltage	Connection	Manual operation	Code no.
EVR 15	AC / DC	Flange	No	032L1224
	AC / DC	Flange	Yes	032L1234
EVR 20	AC / DC	Flange	No	032L1243
	AC / DC	Flange	Yes	032L1253

Table: Flange sets

Type	Connection size		Connection type			Code no.
	[in]	[mm]	Solder [in]	Solder [mm]	Weld [in]	
EVR 15	1/2	–	–	–	Yes	027N1115
	5/8	–	Yes	–	–	027L1117
	–	16	–	Yes	–	027L1116
	3/4	–	–	–	Yes	027N1120
	7/8	–	Yes	–	–	027L1123
	–	22	–	Yes	–	027L1122
EVR 20	3/4	–	–	–	Yes	027N1220
	7/8	–	Yes	–	–	027L1223
	–	22	–	Yes	–	027L1222
	1	–	–	–	Yes	027N1225
	1 1/8	–	Yes	–	–	027L1229
	–	28	–	Yes	–	027L1228

Example

EVR 15 without manual operation,
code no. 032L1224
1/2 in weld flange set,
code no. 027N1115
+ coil with terminal box, 220 V, 50 Hz,
code no. 018F6701

Ordering Flare nuts

Valve bodies for flare connection (NC) and (NO) are supplied without flare nuts.

Table: Flare nuts

Connection size		Code no.
[in]	[mm]	
1/4	6	011L1101
3/8	10	011L1135
1/2	12	011L1103
5/8	16	011L1167

Functions

EVR® solenoid valves are designed on two different principles:

1. Direct operation
2. Servo operation

1. Direct operation (NC)

EVR 2 – EVR 3 are direct operated. The valves open directly for full flow when the armature (3) see [Design](#) moves up into the magnetic field of the coil.

This means that the valves operate with a minimum differential pressure of 0 bar. The seat plate is fitted directly on the armature (3) see [Design](#).

Inlet pressure acts from above on the armature and the valve plate. Thus, the inlet pressure and spring force act to close the valve when there is no current in the coil.

2. Servo operation (NC)

EVR 4 – EVR 22 are servo operated with a "floating" diaphragm (4) see [Design](#). The pilot orifice of stainless steel is placed in the center of the diaphragm. The seat plate is fitted directly to the armature (3) see [Design](#). When there is no current in the coil, the main orifice and pilot orifice are closed. The pilot orifice and main orifice are held closed by the armature spring force and the differential pressure between inlet and outlet sides.

When current is applied to the coil, the armature is drawn up into the magnetic field and opens the pilot orifice. This relieves the pressure above the diaphragm, i.e. the space above the diaphragm becomes connected to the outlet side of the valve.

The differential pressure between inlet and outlet sides then presses the diaphragm away from the main orifice and opens it for full flow. Therefore a certain minimum differential pressure is necessary to open the valve and keep it open. For EVR 4 – EVR 22 valves the minimum differential pressure for safe operation is 0.03 bar.

When the current is switched off, the pilot orifice is closed. Via the equalization holes in the diaphragm, the pressure above the diaphragm rises to the same value as the inlet pressure and the diaphragm closes the main orifice.

EVR 25, EVR 32 and EVR 40 are servo operated piston valves. The servo piston (16) see [Design](#) with sealing face closes against the valve seat by means of the differential pressure between inlet and outlet side of the valve and the force of the compression spring. When the coil is switched on, the pilot orifice opens. This relieves the pressure on the piston spring side of the valve. The differential pressure will then open the valve. The minimum differential pressure for safe operation is 0.2 bar.

EVR (NO) has the opposite function to EVR (NC), i.e. it is open with de-energized coil. EVR (NO) is available with servo operation only.

2.1. Bi-flow operation (NC)

EVRC is a servo operated solenoid valve with a special diaphragm with built-in non- return valve.

EVRC allows flow in both directions and can be used in liquid lines in reversible systems such as heat pumps or reverse hot gas defrost. During the refrigeration period EVRC works as a normal solenoid valve, while during defrost it allows the condensed liquid to return to the liquid manifold.

During the defrosting period the coil for EVRC must be energized. When EVRC is de-energized (closed), the refrigerant will be stopped only in the direction of normal flow.

2.2. Manual stem operation for EVR 6 - EVR 25 NC

EVR 6 - EVR 25 NC are available with optional manual stem operation to manually force the NC valve open when the coil is de-energized.

The protective cap should be removed and the manual stem (12) [Design](#) should be rotated until the valve is fully open. It takes approx. 6 cycles from fully closed, to reach the fully open position.

After manual operation is completed, the valve should manually be closed again and the protective cap mounted.

NOTE:

Alternatively, all EVR NC and NO valves can be manually operated by removing the coil and force the valve open or closed by using a solenoid valve tester (permanent magnet) code no. 018F0091.

Media

Refrigerants

R1234yf, R1234ze(E), R125, R134a, R152a, R22, R290, R32, R404A, R407C, R407F, R407H, R410A, R413A, R417A, R422A, R422B, R422D, R438A, R422A, R422B, R422D, R438A, R442A, R444B, R447A, R447B, R448A, R449A, R449B, R450A, R452A, R452B, R454A, R454B, R454C, R455A, R463A, R507A, R512A, R513A, R513B, R515A, R515B, R516A, R600, R600a.

For a complete list of approved refrigerants, visit store.danfoss.com and search for individual code numbers, where refrigerants are listed as part of technical data.

Note:

Special note for R1234yf, R1234ze, R152A, R290, R32, R444B, R452B, R454A, R454B, R454C, R455A, R516A, R600 and R600a: This product is validated in accordance to ATEX, ISO 5149, IEC 60335-2-24, IEC 60335-2-40 and UL. Ignition risk is evaluated in accordance to ISO 5149 and IEC 60335.

The EVR 2 – EVR 22 with solder connections and without manual stem can be applied on systems with R1234yf, R152A, R290, R32, R444B, R452B, R454A, R454B, R454C, R455A, R516A, R600 and R600a as the working fluid.

EVR 2-15 flare connections are only approved for A1 and A2L refrigerants

Note:

Excluded from this EVR with 1 3/8 inch / 35mm and larger connections related to higher PED requirements.

The EVR 2-EVR 40 versions with solder and flare connection and without manual stem can be applied to oil-free systems: R1234ze(E)

EVR 2 - EVR 22 versions with solder and flare connections and without manual stem can be applied to oil-free systems R513A, R515B, R516A

Note:

EVR 2-22 (R516A): Excluded from this EVR with 1 3/8 inch / 35mm and larger connections related to higher PED requirements.

For countries where safety standards are not an indispensable part of the safety system Danfoss recommends the installer gets a third party approval of any system containing flammable refrigerant.

Note:

Please follow specific selection criteria stated in the datasheet for these particular refrigerants.

Media temperature

-40 – 105 °C, Max. 130 °C during defrosting

For R1234ze(E) Media temperature: -20 – 90 °C (105 °C for transient condition).

Product details

General data

Ambient temperature and enclosure for coil

See separate data sheet for solenoid and ATEX coils.

Figure: Max. working pressure in bar in relation to media temperature in °C.

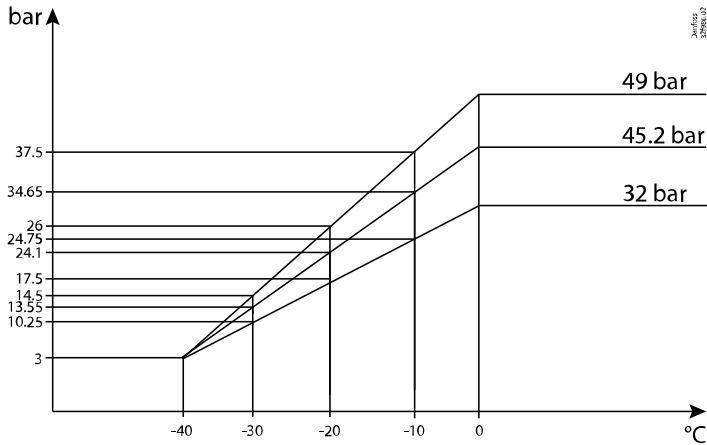

WARNING:

- Special note for EVR PED version: The EVR 2 - EVR 22 versions with solder connections and without manual stem can be applied to 49 bar MWP.
- EVR solder and flare connections: 45.2 bar
- EVR flange connections: 32 bar

NOTE:

Excluded from this EVR 22 with connections 1 3/8 inch / 35 mm related to higher PED requirements.

Capacity

For K_v values refer to the tables in [Ordering](#).

The K_v value of the water flow in [m³/h] at a pressure drop across valve of 1 bar, $\rho = 1000 \text{ kg/m}^3$.

See extended capacity tables on Coolselector®2.

Table: MOPD

Type	Opening differential pressure with standard coil Δp [bar]		
	Min.	Max. (= MOPD) liquid	
		AC coil [10 W]	DC coil [20 W]
EVR 2 NC	0.00	38	33
EVR 3 NC	0.00	38	18
EVR 4 NC	0.03	38	28
EVR 6 NC	0.03	38	28
EVR 6 NO	0.03	21	21
EVR 8 NC	0.03	38	28
EVR 10 NC	0.03	38	20
EVR 10 NO	0.03	21	21
EVR 15 NC	0.03	38	20
EVR 15 NO	0.03	21	21
EVR 18 NC	0.03	38	20
EVR 20 NC	0.03	38	20
EVR 20 NO	0.03	19	19
EVR 22 NC	0.03	38	20
EVR 22 NO	0.03	19	19
EVR 25 NC	0.2	38	17
EVR 32 NC	0.2	38	17
EVR 40 NC	0.2	38	17

NOTE:

For higher MODP 12 W and 20 W AC coils are available on request.

Valve selection based on capacity calculation

As for extended capacity calculations and valve selection based on capacities and refrigerants, please refer to Coolselector®2. Rated and extended capacities are calculated with the Coolselector®2 calculation engine to ARI standards with the ASEREP equations based on laboratory measurements of selected valves.

Rated capacity [kW]

Table: Rated capacity [kW]

Type	R22/R407C	R134a	R404A/R507	R410A	R32	R290	R600a
Liquid							
EVR 2	3.02	2.79	2.04	2.96	4.23	3.36	3.38
EVR 3	5.43	5.02	3.68	5.32	7.61	6.05	6.09
EVR 4	13.68	12.66	9.26	13.41	19.17	15.23	15.33
EVR 6	17.90	16.56	12.12	17.55	25.09	19.93	20.07
EVR 8	21.32	19.73	14.44	20.90	29.88	23.74	23.90
EVR 10	37.62	34.80	25.47	36.88	52.71	41.88	42.17
EVR 15	57.93	53.60	39.23	56.79	81.18	64.49	64.94
EVR 18	75.84	70.16	51.36	74.35	106.26	84.43	85.01
EVR 20	120.29	111.29	81.46	117.93	168.56	133.92	134.85
EVR 22	137.19	126.92	92.90	134.49	192.23	152.73	153.79
EVR 25	149.23	138.06	101.06	146.30	–	–	–
EVR 32	254.97	235.89	172.66	249.96	–	–	–
EVR 40	368.74	341.15	249.71	361.49	–	–	–
Suction vapour							
EVR 2	0.33	0.24	0.29	0.42	0.54	0.41	0.23
EVR 3	0.60	0.44	0.52	0.75	0.96	0.73	0.41
EVR 4	1.51	1.10	1.32	1.90	2.43	1.85	1.03
EVR 6	1.98	1.44	1.72	2.48	3.18	2.42	1.35
EVR 8	2.35	1.71	2.05	2.96	3.78	2.88	1.60
EVR 10	4.15	3.02	3.62	5.22	6.67	5.09	2.83
EVR 15	6.40	4.65	5.57	8.03	10.28	7.83	4.36
EVR 18	8.37	6.09	7.30	10.52	13.45	10.26	5.70
EVR 20	13.28	9.66	11.57	16.68	21.34	16.27	9.04
EVR 22	15.15	11.02	13.20	19.02	24.34	18.55	10.31
EVR 25	16.33	11.79	14.25	20.58	–	–	–
EVR 32	27.90	20.14	24.35	35.16	–	–	–
EVR 40	40.35	29.12	35.21	50.85	–	–	–
Hot gas							
EVR 2	1.35	1.04	1.10	1.65	2.18	1.54	0.94
EVR 3	2.42	1.87	1.99	2.98	3.92	2.76	1.70
EVR 4	6.10	4.70	5.01	7.50	9.86	6.96	4.28
EVR 6	7.99	6.16	6.56	9.81	12.91	9.11	5.61
EVR 8	9.51	7.33	7.81	11.68	15.37	10.85	6.68
EVR 10	16.78	12.94	13.78	20.61	27.12	19.14	11.78
EVR 15	25.85	19.93	21.22	31.74	41.77	29.48	18.14
EVR 18	33.84	26.08	27.77	41.55	54.67	38.59	23.75
EVR 20	53.68	41.37	44.05	65.91	86.72	61.21	37.67
EVR 22	61.22	47.18	50.24	75.17	98.91	69.81	42.96
EVR 25	87.87	67.73	72.12	107.91	–	–	–
EVR 32	150.17	115.75	123.24	184.40	–	–	–
EVR 40	217.22	167.43	178.27	266.74	–	–	–



Rated liquid and suction vapor capacity is based on:

- vaporating temperature $t_e = -10\text{ °C}$
- liquid temperature ahead of valve $t_l = 25\text{ °C}$
- pressure drop in valve $\Delta p = 0.15\text{ bar}$

Rated hot gas capacity is based on:

- condensing temperature $t_c = 40\text{ °C}$
- pressure drop across valve $\Delta p = 0.8\text{ bar}$
- hot gas temperature $t_h = 65\text{ °C}$
- subcooling of refrigerant $\Delta t_{\text{sub}} = 4\text{ K}$

For other refrigerants, please refer to Coolselector®

Design

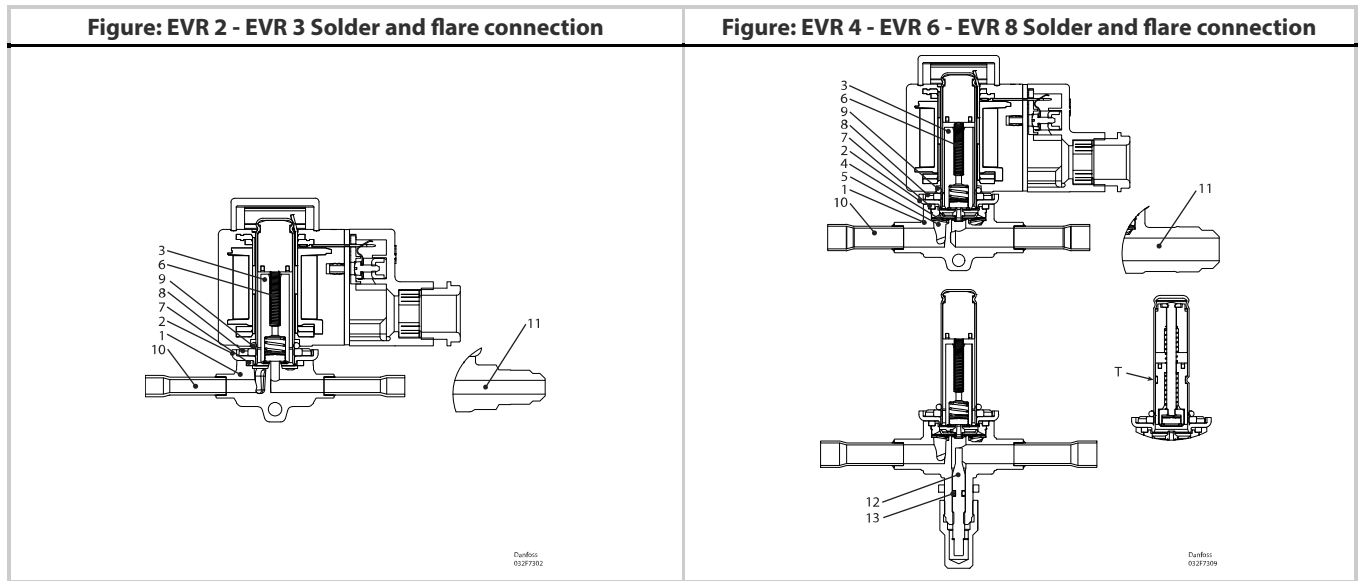

Table: Design and material for EVR 2, EVR 3, EVR 4, EVR 6, EVR 8

Pos. no.	Description	Material
1	Valve housing assembly	Brass
2	Cover	Stainless steel
3	Armature assembly	Stainless steel/PTFE
4	Diaphragm assembly	Stainless steel/PTFE
5	Support washer	Stainless steel
6	Armature spring	Stainless steel
7	Seal	Chloroprene rubber
8	Screws	Stainless steel
9	O-ring	EPDM rubber
10	Solder connection	Copper
11	Flare connection	Brass
12	Manual stem ⁽¹⁾	Brass
13	O-ring	Chloroprene rubber
T	Normally Open (NO) tube design	

⁽¹⁾ Manual stem is not available for EVR 4

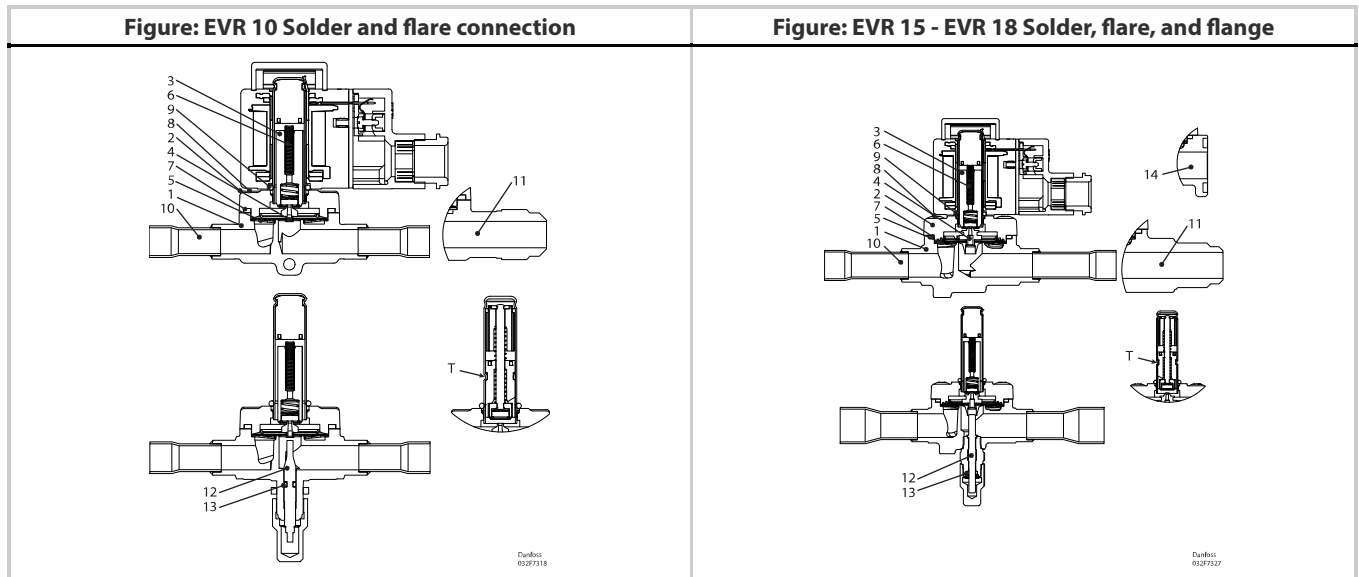

Table: Design and material for EVR 10, EVR 15, EVR 18

Pos. no.	Description	Material
1	Valve housing assembly	Brass
2	Cover	Brass
3	Armature assembly	Stainless steel/PTFE
4	Diaphragm assembly	Stainless steel/PTFE
5	Support washer	Stainless steel
6	Armature spring	Stainless steel
7	Seal	Chloroprene rubber
8	Screws	Stainless steel
9	O-ring	EPDM rubber
10	Solder connection	Copper
11	Flare connection	Brass
12	Manual stem	Brass
13	O-ring	Chloroprene rubber
14	Flange connection	Brass
T	Normally Open (NO) tube design	

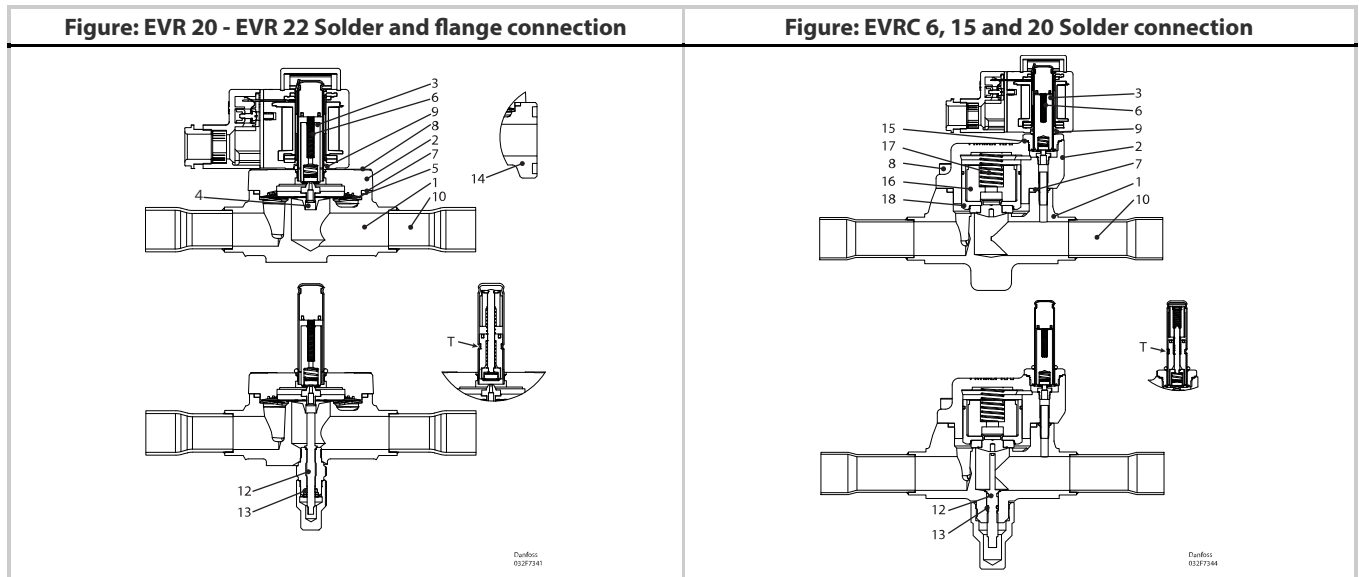

Table: Design and material for EVR 20, EVR 22, EVRC 6, EVRC 15, EVRC 20

Pos. no.	Description	Material
1	Valve housing assembly	Brass
2	Cover	Brass (EVR 20-22, EVRC 15-20) / Stainless steel (EVRC 6)
3	Armature assembly	Stainless steel/PTFE
4	Diaphragm assembly	Stainless steel/PTFE
5	Support washer	Stainless steel
6	Armature spring	Stainless steel
7	Seal	Chloroprene rubber
8	Screws	Stainless steel
9	O-ring	EPDM rubber
10	Solder connection	Copper
11	Flare connection	Brass
12	Manual stem	Brass
13	O-ring	Chloroprene rubber
14	Flange connection	Brass
15	Gasket	Aluminum
16	Insert	Nylon
17	Piston spring	Stainless steel
18	Piston	Stainless steel
T	Normally Open (NO) tube design	

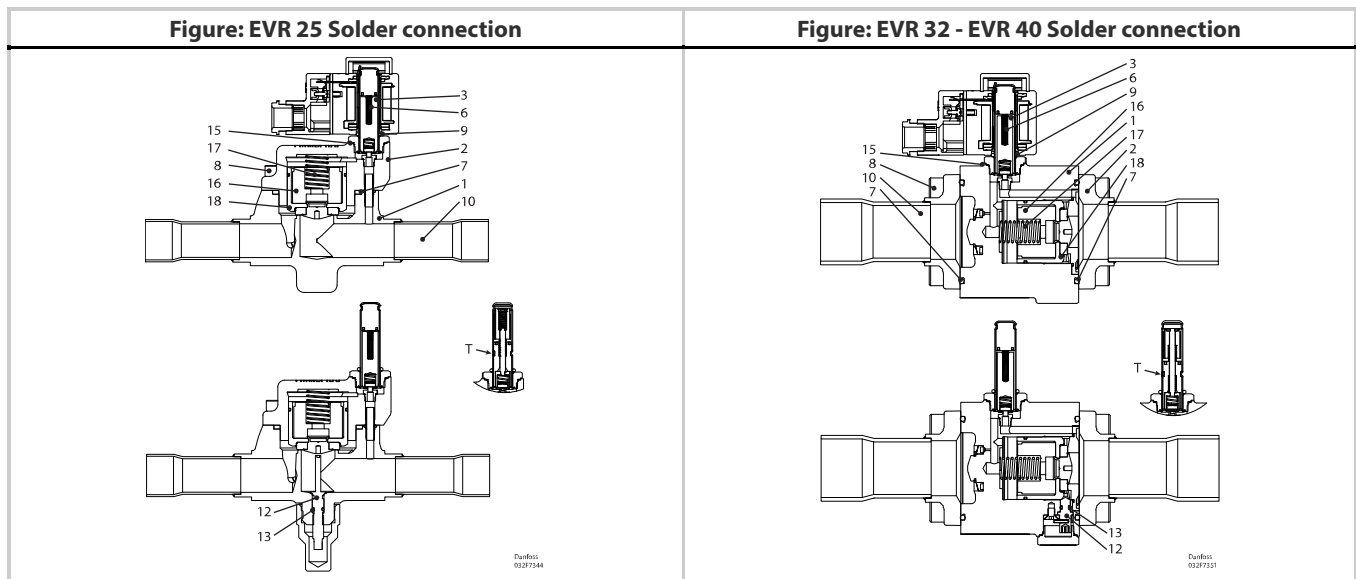

Table: Design and material for EVR 32, EVR 40, EVR Solder connection

Pos. no.	Description	Material - EVR 25	Material - EVR 32-40
1	Valve housing assembly	Brass	Cast iron
2	Cover	Cast iron	Brass
3	Armature assembly	Stainless steel/PTFE	Stainless steel/PTFE
4	Armature spring	Stainless steel	Stainless steel
5	Seal	Chloroprene rubber	Chloroprene rubber
6	Screws	Stainless steel	Stainless steel
7	O-ring	EPDM rubber	EPDM rubber
8	Solder connection	Copper	Copper
9	Manual stem	Brass	Brass
10	O-ring	Chloroprene rubber	Chloroprene rubber
11	Gasket	Aluminum	Aluminum
12	Insert	Nylon	Nylon
13	Piston spring	Stainless steel	Stainless steel
14	Piston	Stainless steel	Stainless steel
T	Normally Open (NO) tube design		

Dimensions

Dimensions and weights for EVR 2 - EVR 3 Solder connection

Figure: EVR and Cable coil

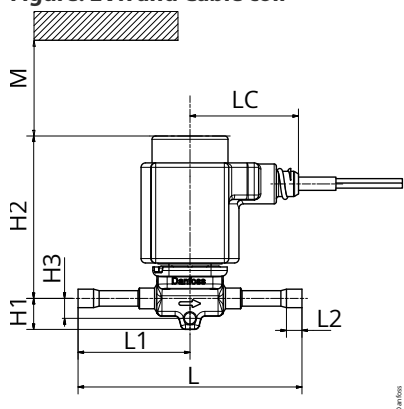

Danfoss
03077303

Figure: EVR and DIN plug coil

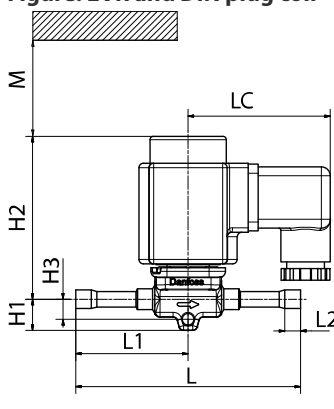

Danfoss
03077301

Figure: EVR and Terminal box coil

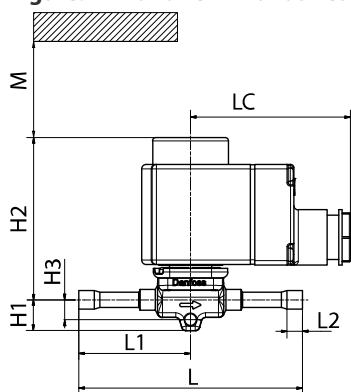

Danfoss
03077304

Figure: End view

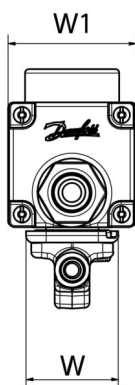

Table: Dimensions and weights for EVR 2 - EVR 3 Solder connection

Type	Connection size		H1	H2	H3	M min.	L	L1	L2	LC	W	W1 max.	Net weight without coil ⁽¹⁾
	[in]	[mm]											
Valve body													
EVR 2	¼	6	14	73	9	65	101	50.5	7	-	34	-	0.16
EVR 3	¼	6	14	73	9	65	101	50.5	7	-	34	-	0.16
	⅜	10	14	73	9	65	117	58.5	8	-	34	-	0.17
Coil													
Cable coil										49	-	46	-
DIN plug coil										64	-	47	-
Terminal box coil 10 W										72	-	47	-
Terminal box coil 12 / 20 W										80	-	68	-

⁽¹⁾ Net weight of coil for 10 W is approx. 0.3 kg and for 12 and 20 W is approx. 0.5 kg

For 3D CAD models on individual code numbers visit store.danfoss.com

Dimensions and weights for EVR 4 - EVR 6 - EVR 8 Solder connection

Figure: EVR and Cable coil

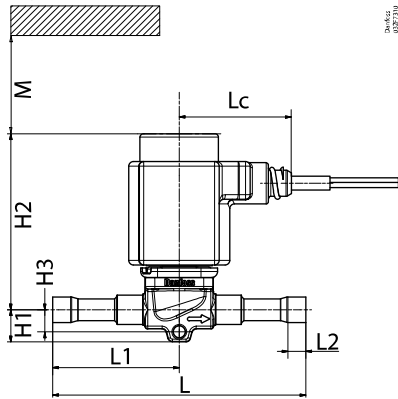

Figure: EVR and DIN plug coil

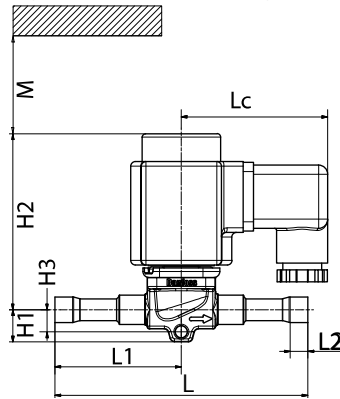

Figure: EVR and Terminal box coil

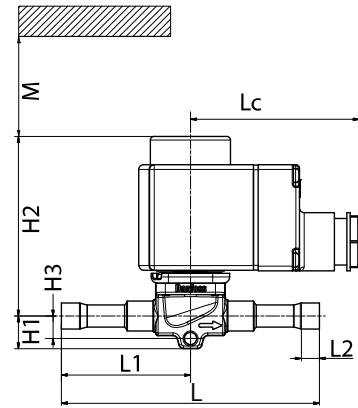

Figure: Manual stem

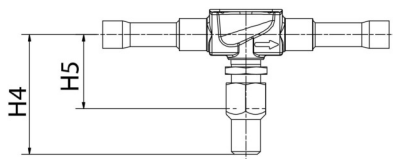

Figure: End view

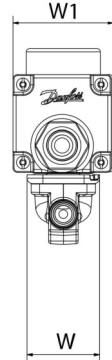

Table: Dimensions and weights for EVR 4 - EVR 6 - EVR 8 Solder connection

Type	Connection size		Manual operation	H1	H2	H3	H4	H5	M min.	L	L1	L2	LC	W	W1 max.	Net weight without coil ⁽¹⁾ [kg]
	[in]	[mm]		[mm]	[mm]	[mm]	[mm]	[mm]	[mm]	[mm]	[mm]	[mm]	[mm]	[mm]	[mm]	
Valve body																
EVR 4	3/8	10	No	14	78	10	-	-	65	117	58.5	8	-	34	-	0.19
EVR 6	3/8	10	Yes	14	78	10	48	30	65	117	58.5	8	-	34	-	0.19
	3/8	10	No	14	78	10	-	-	65	111	55.5	8	-	34	-	0.19
	1/2	12	Yes	14	78	10	48	30	65	127	63.5	10	-	34	-	0.2
	1/2	12	No	14	78	10	-	-	65	127	63.5	10	-	34	-	0.2
EVR 8	1/2	12	Yes	14	78	10	48	30	65	127	63.5	10	-	34	-	0.2
	1/2	12	No	14	78	10	-	-	65	127	63.5	10	-	34	-	0.2
	3/8	16	No	14	78	10	-	-	65	163	81.5	12	-	34	-	0.2
Coil																
Cable coil													49	-	46	-
DIN plug coil													64	-	47	-
Terminal box coil 10 W													72	-	47	-
Terminal box coil 12 / 20 W													80	-	68	-

⁽¹⁾ Net weight of coil for 10 W is approx. 0.3 kg and for 12 and 20 W is approx. 0.5 kg

For 3D CAD models on individual code numbers visit store.danfoss.com

Dimensions and weights for EVR 10 Solder connection

Figure: EVR and Cable coil

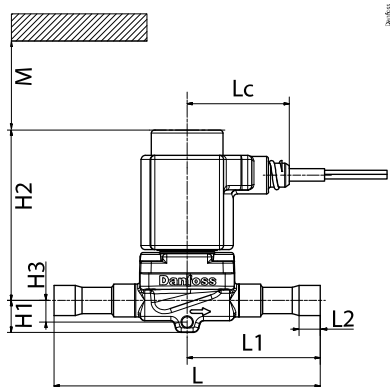

Figure: EVR and DIN plug coil

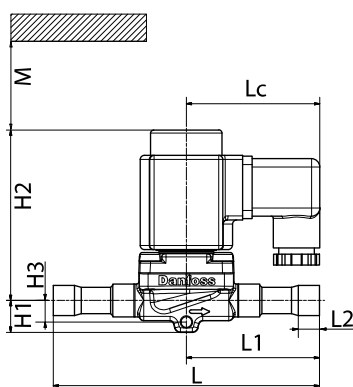

Figure: EVR and Terminal box coil

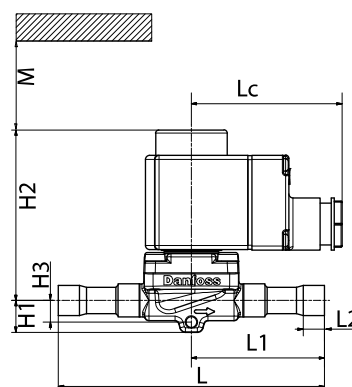

Figure: Manual stem

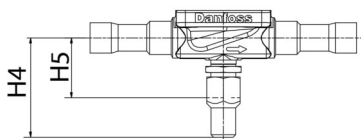

Figure: End view



Table: Dimensions and weights for EVR 10 Solder connection

Type	Connection size		Manual operation	H1	H2	H3	H4	H5	M min.	L	L1	L2	LC	W	W1 max.	Net weight without coil ⁽¹⁾ [kg]
	[in]	[mm]		[mm]	[mm]	[mm]	[mm]	[mm]	[mm]	[mm]	[mm]	[mm]	[mm]	[mm]	[mm]	
Valve body																
EVR 10	1/2	12	Yes	15	82	10	48	29	65	128	64	10	-	46	-	0.39
	3/8	10	No	15	82	10	-	-	65	118	59	-	-	46	-	0.34
	1/2	16	No	15	82	10	-	-	65	163	81.5	12	-	46	-	0.38
	3/4	16	Yes	15	82	10	48	29	65	163	81.5	12	-	46	-	0.4
Coil																
Cable coil													49	-	46	-
DIN plug coil													64	-	47	-
Terminal box coil 10 W													72	-	47	-
Terminal box coil 12 / 20 W													80	-	68	-

⁽¹⁾ Net weight of coil for 10 W is approx. 0.3 kg and for 12 and 20 W is approx. 0.5 kg

For 3D CAD models on individual code numbers visit store.danfoss.com

Dimensions and weights for EVR 15 - EVR 18 Solder connection

Figure: EVR and Cable coil

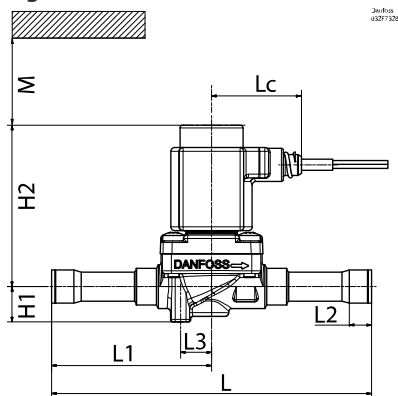

Figure: EVR and DIN plug coil

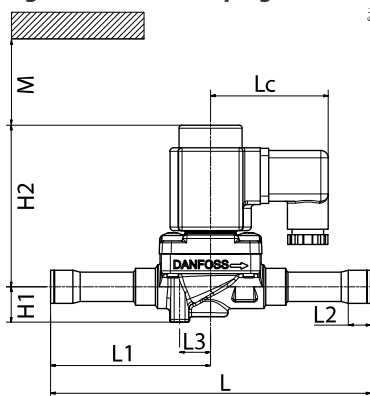

Figure: EVR and Terminal box coil

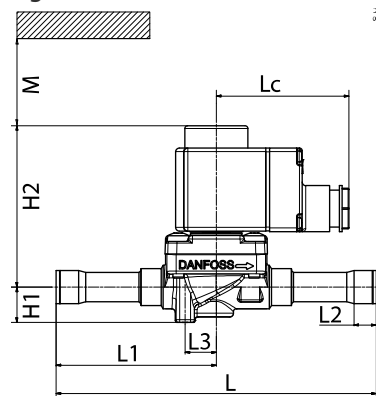

Figure: Manual stem

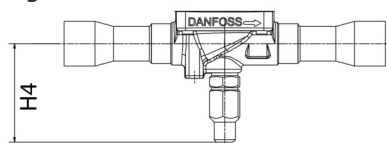

Figure: End view

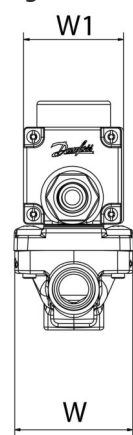

Table: Dimensions and weights for EVR 15 - EVR 18 Solder connection

Type	Connection size		Manual operation	H1	H2	H4	M min.	L	L1	L2	L3	Lc	W	W1 max.	Net weight without coil ⁽¹⁾
	[in]	[mm]		[mm]	[mm]	[mm]	[mm]	[mm]	[mm]	[mm]	[mm]	[mm]	[mm]	[mm]	[mm]
Valve body															
EVR 15	1/8"	16	Yes	19	89	54	65	174	87	12	17	-	56	-	0.7
	1/4"	16	No	19	89	-	65	174	87	12	17	-	56	-	0.7
	3/8"	22	No	19	89	-	65	174	87	17	17	-	56	-	0.7
EVR 18	1/4"	22	Yes	19	89	54	65	179	89.5	17	17	-	56	-	0.7
Coil															
Cable coil												49	-	46	-
DIN plug coil												64	-	47	-
Terminal box coil 10 W												72	-	47	-
Terminal box coil 12 / 20 W												80	-	68	-

⁽¹⁾ Net weight of coil for 10 W is approx. 0.3 kg and for 12 and 20 W is approx. 0.5 kg

For 3D CAD models on individual code numbers visit store.danfoss.com

Dimensions and weights for EVR 20 - EVR 22 Solder connection

Figure: EVR and Cable coil

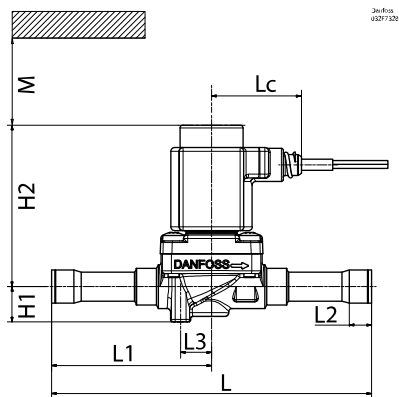

Figure: EVR and DIN plug coil

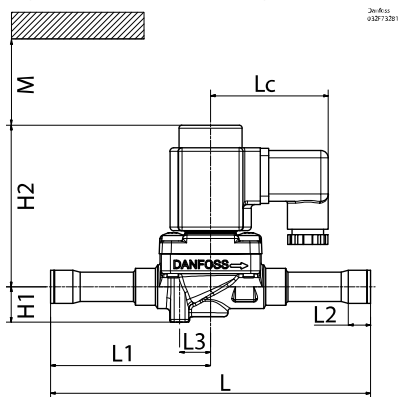

Figure: EVR and Terminal box coil

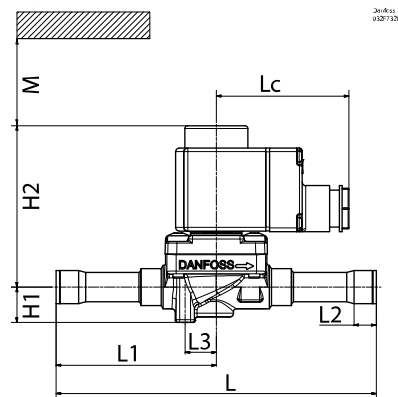

Figure: Manual stem

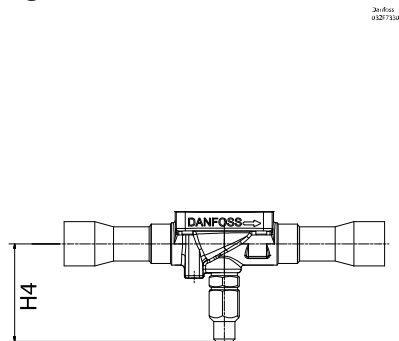

Figure: End view

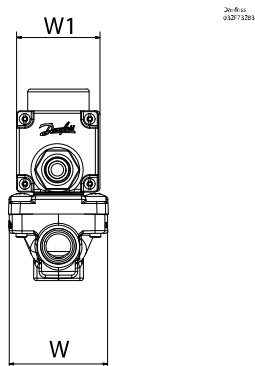

Table: Dimensions and weights for EVR 20 - EVR 22 Solder connection

Type	Connection size		Manual operation	H1	H2	H4	M min.	L	L1	L2	L3	Lc	W	W1 max.	Net weight without coil ⁽¹⁾
	[in]	[mm]		[mm]	[mm]	[mm]	[mm]	[mm]	[mm]	[mm]	[mm]	[mm]	[mm]	[mm]	[mm]
Valve body															
EVR 20	3/8	22	Yes	19	93	56	65	190	95	17	20	-	72	-	1.26
	3/8	22	No	19	93	-	65	190	95	17	20	-	72	-	1.26
	1 1/8	28	No	19	93	-	65	217	108.5	20	20	-	72	-	1.31
EVR 22	1 1/8	28	Yes	19	93	56	65	222	111	20	20	-	72	-	1.31
	1 1/8	28	No	19	93	-	65	267	133.5	20	20	-	72	-	1.47
	1 3/8	35	No	19	93	-	65	292	146	25	20	-	72	-	1.47
Coil															
Cable coil												49	-	46	-
DIN plug coil												64	-	47	-
Terminal box coil 10 W												72	-	47	-
Terminal box coil 12 / 20 W												80	-	68	-

⁽¹⁾ Net weight of coil for 10 W is approx. 0.3 kg and for 12 and 20 W is approx. 0.5 kg

For 3D CAD models on individual code numbers visit store.danfoss.com

Dimensions and weights for EVR 25 Solder connection

Figure: EVR and Cable coil

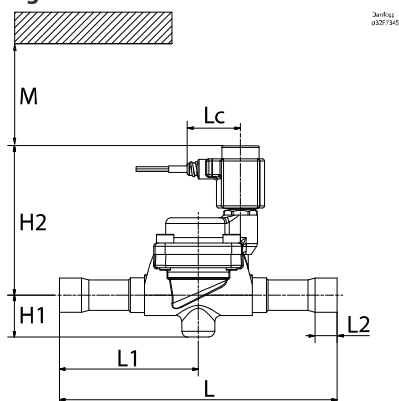

Figure: EVR and DIN plug coil

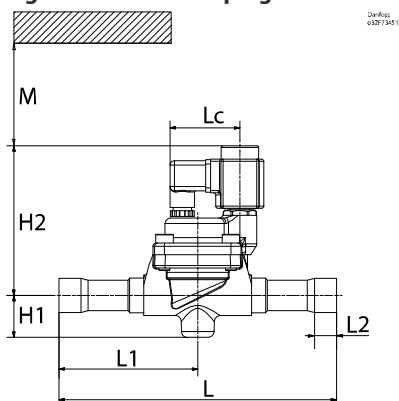

Figure: EVR and Terminal box coil

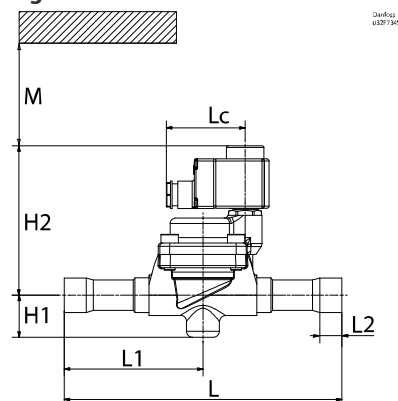

Figure: Manual stem

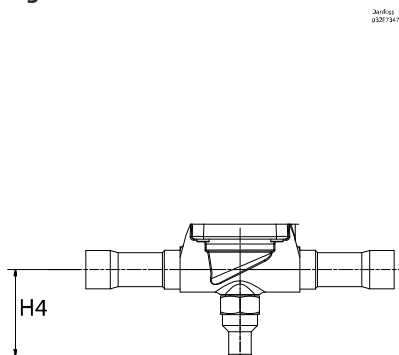

Figure: End view

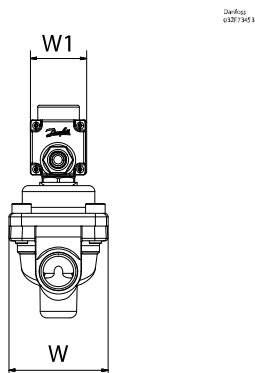

Table: Dimensions and weights for EVR 25 Solder connection

Type	Connection size		Manual operation	H1	H2	H4	M min.	L	L1	L2	Lc	W	W1 max.	Net weight without coil ⁽²⁾
	[in]	[mm]		[mm]	[mm]	[mm]	[mm]	[mm]	[mm]	[mm]	[mm]	[mm]	[mm]	[mm]
Valve body														
EVR 25	1 1/8	28	Yes	39	138	71	65	255	127.5	20	-	82	-	2.67 ⁽¹⁾
	1 1/8	28	No	39	138	-	65	255	127.5	20	-	82	-	2.67 ⁽¹⁾
	1 3/8	35	Yes	39	138	71	65	281	140.5	25	-	82	-	2.80 ⁽¹⁾
	1 3/8	35	No	39	138	-	65	281	140.5	25	-	82	-	2.80 ⁽¹⁾
Coil														
Cable coil											49	-	46	-
DIN plug coil											64	-	47	-
Terminal box coil 10 W											72	-	47	-
Terminal box coil 12 / 20 W											80	-	68	-

⁽¹⁾ Manual stem: +0.060 kg

⁽²⁾ Net weight of coil for 10 W is approx. 0.3 kg and for 12 and 20 W is approx. 0.5 kg

For 3D CAD models on individual code numbers visit store.danfoss.com

Dimensions and weights for EVR 32 - EVR 40 Solder connection

Figure: EVR and Cable coil

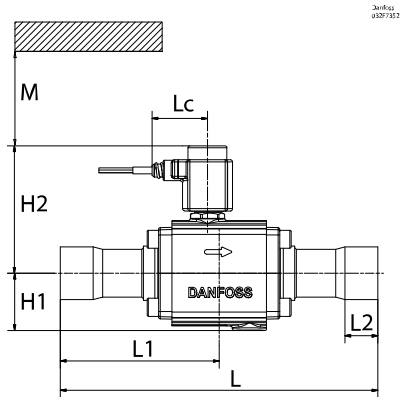

Figure: EVR and DIN plug coil

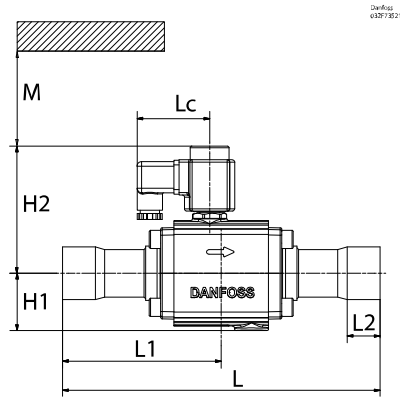

Figure: EVR and Terminal box coil

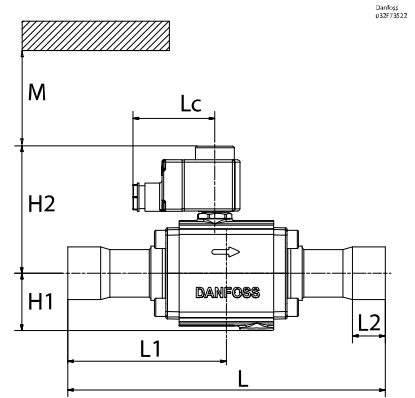

Figure: Manual stem

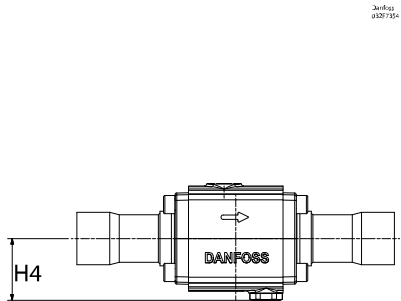

Figure: End view

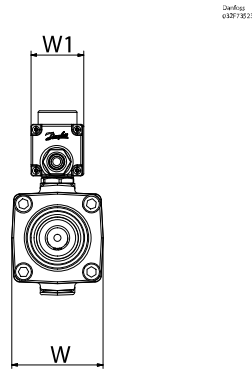

Table: Dimensions and weights for EVR 32 - EVR 40 Solder connection

Type	Connection size		Manual operation	H1	H2	H4	M min.	L	L1	L2	Lc	W	W1 max.	Net weight without coil ⁽²⁾ [kg]
	[in]	[mm]		[mm]	[mm]	[mm]	[mm]	[mm]	[mm]	[mm]	[mm]	[mm]	[mm]	
Valve body														
EVR 32	1 3/8	35	Yes	-	111	55	65	280	140	25	-	81	-	4.3
	1 3/8	35	No	51	111	-	65	280	140	25	-	81	-	4.3
	1 1/2	42	Yes	-	111	55	65	280	140	29	-	81	-	4.4
	1 1/2	42	No	51	111	-	65	280	140	29	-	81	-	4.4
	2 1/8	-	Yes	-	111	55	65	280	140	34	-	80	-	4.57
	2 1/8	-	No	51	111	-	65	280	140	34	-	80	-	4.57
EVR 40	1 1/2	42	Yes	-	111	55	65	280	140	29	-	81	-	4.4
	1 1/2	42	No	51	111	-	65	280	140	29	-	81	-	4.4
	2 1/8	-	Yes	-	111	55	65	280	140	34	-	80	-	4.57
	2 1/8	-	No	51	111	-	65	280	140	34	-	80	-	4.57
Coil														
Cable coil											49	-	46	-
DIN plug coil											64	-	47	-
Terminal box coil 10W											72	-	47	-
Terminal box coil 12 / 20W											80	-	68	-

⁽²⁾ Net weight of coil for 10W is approx. 0.3 kg and for 12 and 20W is approx. 0.5 kg

For 3D CAD models on individual code numbers visit store.danfoss.com

Dimensions and weights for EVRC 6 Solder connection

Figure: EVRC and Cable coil

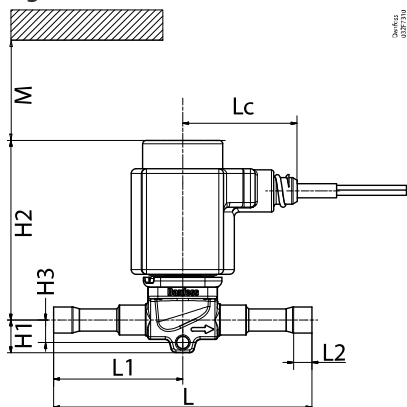

Danfoss
03073110

Figure: EVRC and DIN plug coil

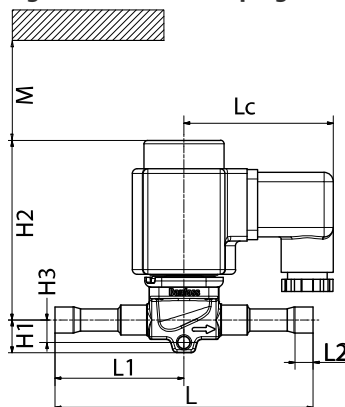

Danfoss
03073110

Figure: EVRC and Terminal box coil

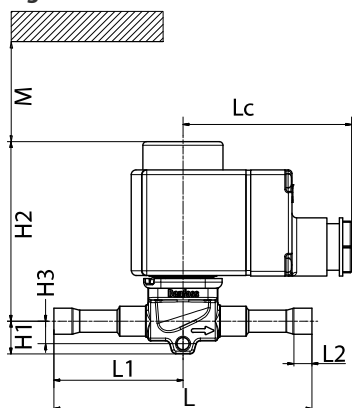

Danfoss
03073110

Figure: End view

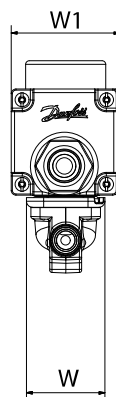

Danfoss
03073110

Table: Dimensions and weights for EVRC 6 Solder connection

Type	Connection size		Manual operation	H1	H2	H3	H4	H5	M min.	L	L1	L2	LC	W	W1 max.	Net weight without coil ⁽¹⁾ [kg]
	[in]	[mm]		[mm]	[mm]	[mm]	[mm]	[mm]	[mm]	[mm]	[mm]	[mm]	[mm]	[mm]	[mm]	
Valve body																
EVRC 6	3/8	10	No	14	78	10	-	-	65	111	55.5	8	-	34	-	0.19
Coil																
Cable coil													49	-	46	-
DIN plug coil													64	-	47	-
Terminal box coil 10 W													72	-	47	-
Terminal box coil 12 / 20 W													80	-	68	-

⁽¹⁾ Net weight of coil for 10 W is approx. 0.3 kg and for 12 and 20 W is approx. 0.5 kg

For 3D CAD models on individual code numbers visit store.danfoss.com

Dimensions and weights for EVRC 15 Solder connection

Figure: EVR and Cable coil

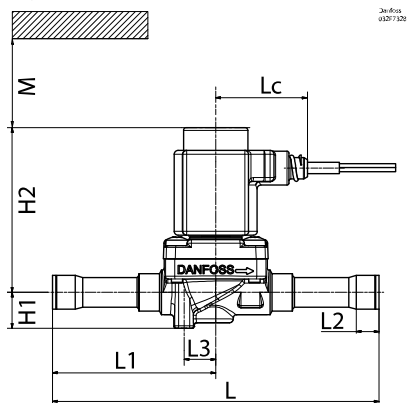

Figure: EVR and DIN plug coil

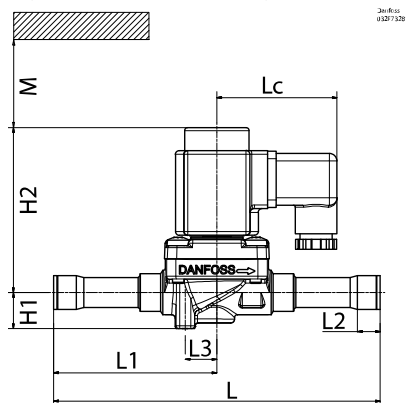

Figure: EVR and Terminal box coil

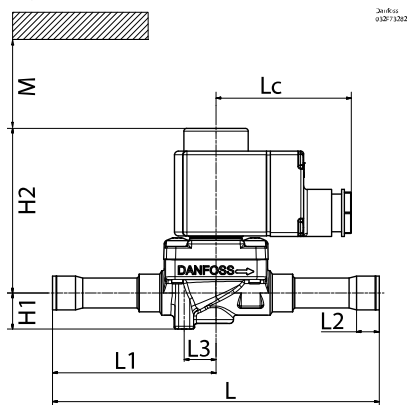

Figure: End view

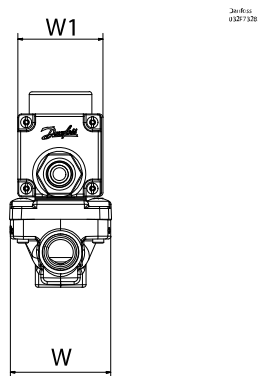

Table: Dimensions and weights for EVRC 15 Solder connection

Type	Connection		Manual operation	H1	H2	M min.	M min.	L	L1	L2	Lc	W	W1 max.	Net weight without coil ⁽¹⁾
	[in]	[mm]		[mm]	[mm]	[mm]	[mm]	[mm]	[mm]	[mm]				
Valve body														
EVRC 15	3/8"	16	No	19	89	65	174	87	12	17	-	56	-	0.7
Coil														
Cable coil											49	-	46	-
DIN plug coil											64	-	47	-
Terminal box coil 10 W											72	-	47	-
Terminal box coil 12 / 20 W											80	-	68	-

⁽¹⁾ Net weight of coil for 10 W is approx. 0.3 kg and for 12 and 20 W is approx. 0.5 kg

For 3D CAD models on individual code numbers visit store.danfoss.com

Dimensions and weights for EVRC 20 Solder connection

Figure: EVR and Cable coil

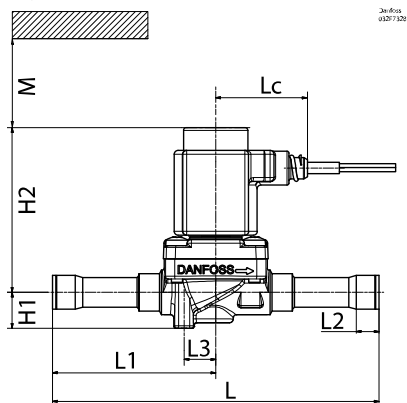

Figure: EVR and DIN plug coil

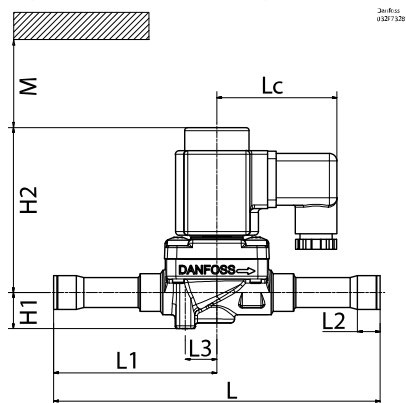

Figure: EVR and Terminal box coil

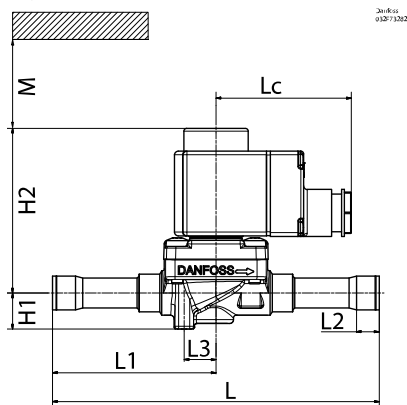

Figure: End view

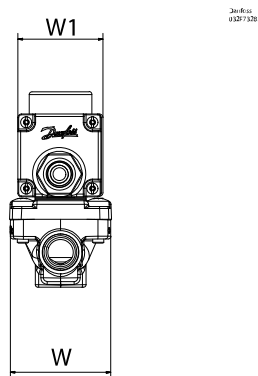

Table: Dimensions and weights for EVRC 20 Solder connection

Type	Connection size		Manual operation	H1	H2	M min.	M min.	L	L1	L2	Lc	W	W1 max.	Net weight without coil ⁽¹⁾
	[in]	[mm]		[mm]	[mm]	[mm]	[mm]	[mm]	[mm]	[mm]	[mm]	[mm]	[mm]	[mm]
Valve body														
EVRC 20	7/8	22	No	19	93	65	190	95	17	20	-	72	-	1.26
Coil														
Cable coil											49	-	46	-
DIN plug coil											64	-	47	-
Terminal box coil 10 W											72	-	47	-
Terminal box coil 12 / 20 W											80	-	68	-

⁽¹⁾ Net weight of coil for 10 W is approx. 0.3 kg and for 12 and 20 W is approx. 0.5 kg

For 3D CAD models on individual code numbers visit <https://store.danfoss.com/>

Dimensions and weights for EVR 2 - EVR 3 Flare connection

Figure: EVR and Cable coil

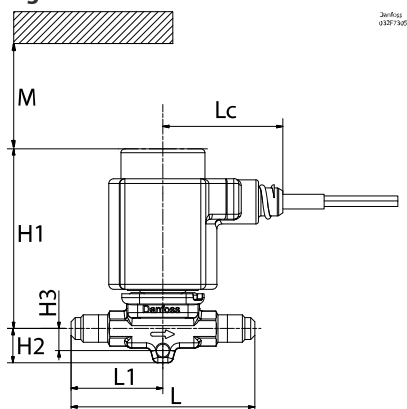

Danfoss
03B7362

Figure: EVR and DIN plug coil

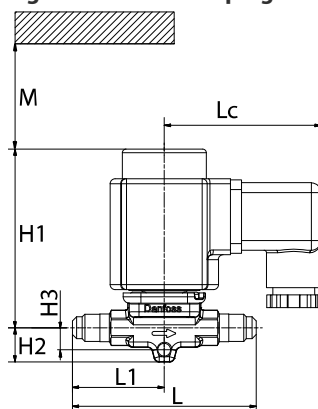

Danfoss
03B73621

Figure: EVR and Terminal box coil

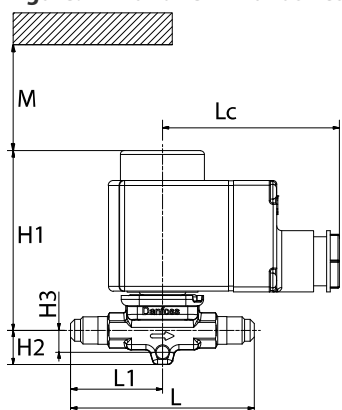

Danfoss
03B73622

Figure: End view



Danfoss
03B73623

Table: Dimensions and weights for EVR 2 - EVR 3 Flare connection

Type	Connection size		H1	H2	H3	M min.	L	L1	Lc	W	W1 max.	Net weight without coil ⁽¹⁾ [kg]
	[in]	[mm]	[mm]	[mm]	[mm]	[mm]	[mm]	[mm]	[mm]	[mm]	[mm]	
Valve body												
EVR 2	¼	6	14	73	9	65	75	37.5	-	34	-	0.18
EVR 3	¼	6	14	73	9	65	75	37.5	-	34	-	0.18
	⅜	10	14	73	9	65	75	37.5	-	34	-	0.18
Coil												
Cable coil									49	-	46	-
DIN plug coil									64	-	47	-
Terminal box coil 10 W									72	-	47	-
Terminal box coil 12 / 20 W									80	-	68	-

⁽¹⁾ Net weight of coil for 10 W is approx. 0.3 kg and for 12 and 20 W is approx. 0.5 kg

For 3D CAD models on individual code numbers visit store.danfoss.com

Dimensions and weights for EVR 6 Flare connection

Figure: EVR and Cable coil

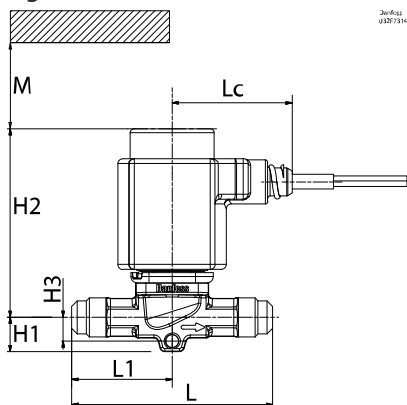

Figure: EVR and DIN plug coil

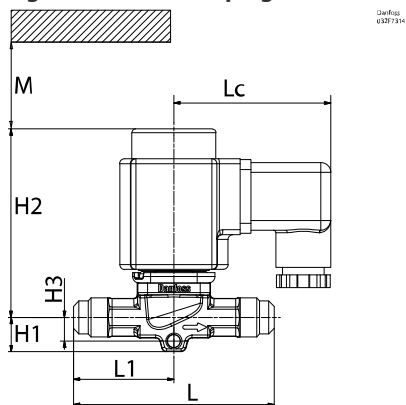

Figure: EVR and Terminal box coil

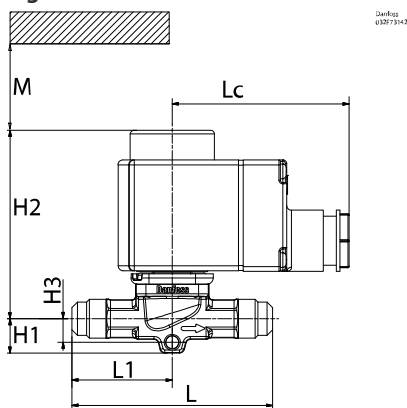

Figure: End view

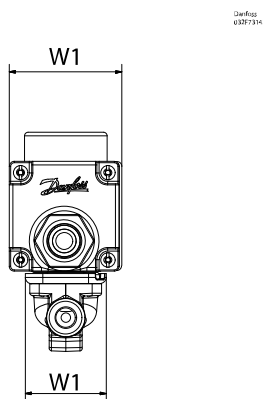

Table: Dimensions and weights for EVR 6 Flare connection

Type	Connection size		H1	H2	H3	M min.	L	L1	Lc	W	W1 max.	Net weight without coil ⁽¹⁾ [kg]
	[in]	[mm]	[mm]	[mm]	[mm]	[mm]	[mm]	[mm]	[mm]	[mm]	[mm]	
Valve body												
EVR 6	3/8	10	14	77	10	65	82	41	-	34	-	0.21
	1/2	12	14	77	10	65	88	44	-	34	-	0.22
Coil												
Cable coil									49	-	46	-
DIN plug coil									64	-	47	-
Terminal box coil 10 W									72	-	47	-
Terminal box coil 12 / 20 W									80	-	68	-

⁽¹⁾ Net weight of coil for 10 W is approx. 0.3 kg and for 12 and 20 W is approx. 0.5 kg

For 3D CAD models on individual code numbers visit store.danfoss.com

Dimensions and weights for EVR 10 Flare connection

Figure: EVR and Cable coil

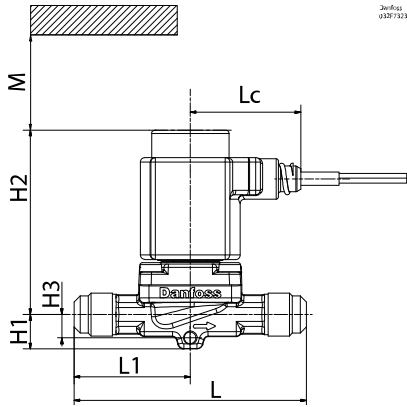

Figure: EVR and DIN plug coil

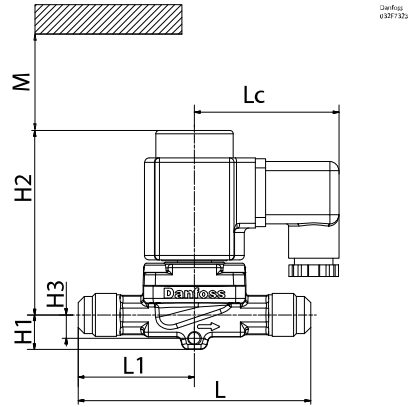

Figure: EVR and Terminal box coil

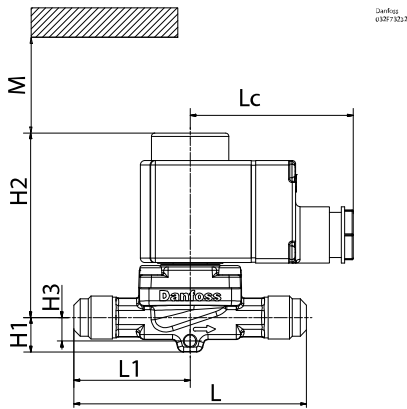

Figure: End view

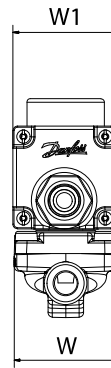

Table: Dimensions and weights for EVR 10 Flare connection

Type	Connection size		H1	H2	H3	M min.	L	L1	Lc	W	W1 max.	Net weight without coil ⁽¹⁾ [kg]
	[in]	[mm]										
Valve body												
EVR 10	½	12	15	82	10	65	103	51.5	-	46	-	0.44
	¾	16	15	82	10	65	110	55	-	46	-	0.45
Coil												
Cable coil									49	-	46	-
DIN plug coil									64	-	47	-
Terminal box coil 10 W									72	-	47	-
Terminal box coil 12 / 20 W									80	-	68	-

⁽¹⁾ Net weight of coil for 10 W is approx. 0.3 kg and for 12 and 20 W is approx. 0.5 kg

For 3D CAD models on individual code numbers visit store.danfoss.com

Dimensions and weights for EVR 15 Flare connection

Figure: EVR and Cable coil

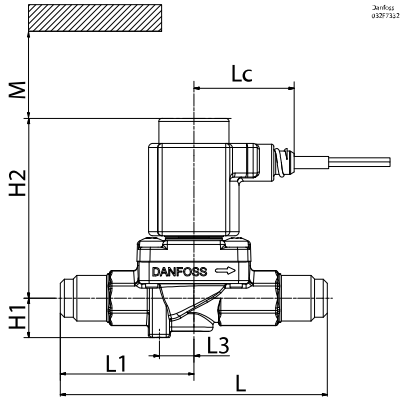

Figure: EVR and DIN plug coil

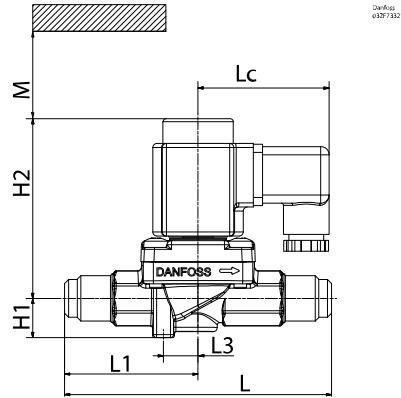

Figure: EVR and Terminal box coil

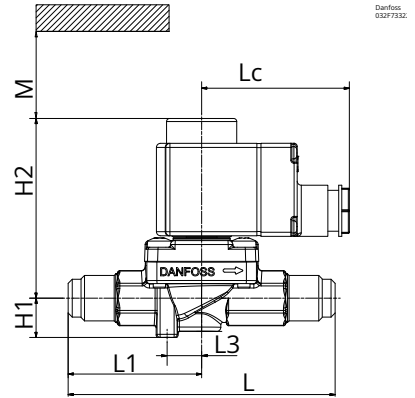

Figure: Manual stem

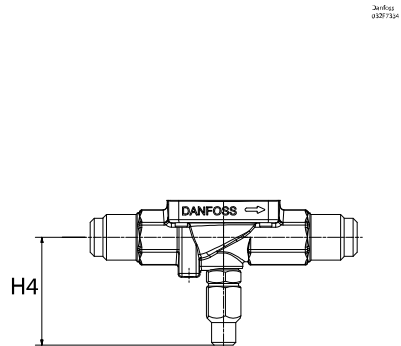

Figure: End view

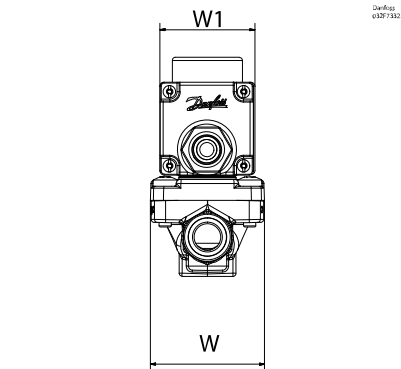

Table: Dimensions and weights for EVR 15 Flare connection

Type	Connection size		Manual operation	H1	H2	H3	M min.	L	L1	Lc	W	W1 max.	Net weight without coil ⁽¹⁾ [kg]
	[in]	[mm]		[mm]	[mm]	[mm]	[mm]	[mm]	[mm]	[mm]	[mm]	[mm]	
Valve body													
EVR 15	3/8	16	Yes	19	89	53	65	131	65.5	17	-	56	-
	3/8	16	No	19	89	-	65	131	65.5	17	-	56	-
Coil													
Cable coil										49	-	46	-
DIN plug coil										64	-	47	-
Terminal box coil 10 W										72	-	47	-
Terminal box coil 12 / 20 W										80	-	68	-

⁽¹⁾ Net weight of coil for 10 W is approx. 0.3 kg and for 12 and 20 W is approx. 0.5 kg

For 3D CAD models on individual code numbers visit store.danfoss.com

Dimensions and weights for EVR 15 Flange connection

Figure: EVR and Cable coil

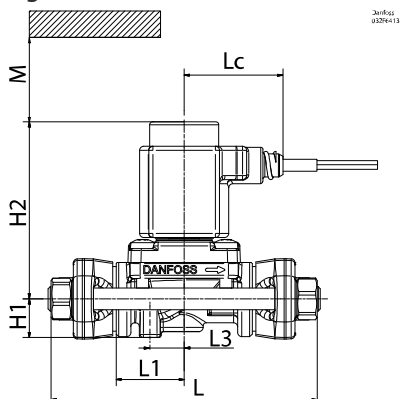

Figure: EVR and DIN plug coil

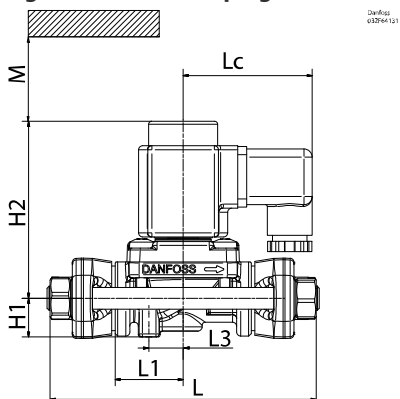

Figure: EVR and Terminal box coil

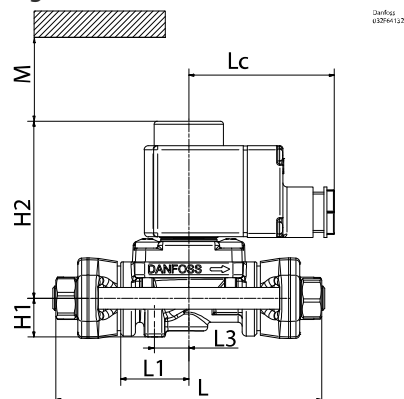

Figure: Manual stem

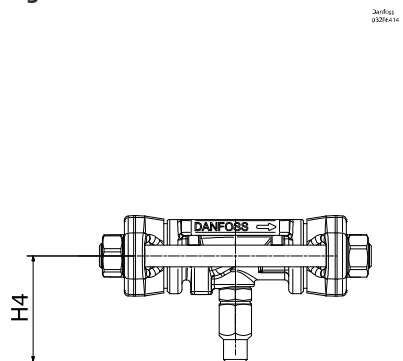

Figure: End view

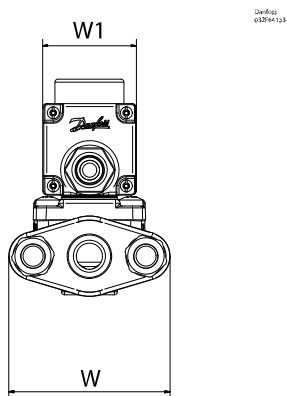

Table: Dimensions and weights for EVR 15 Flange connection

Type	Manual operation	H1	H2	H4	M min.	L	L1	L3	Lc	W	W1 max.	Net weight without coil ⁽¹⁾ [kg]
		[mm]	[mm]	[mm]	[mm]	[mm]	[mm]	[mm]	[mm]	[mm]	[mm]	
Valve body												
EVR 15	Yes	19	89	53	65	126	33.8	17	-	80	-	0.64
	No	19	89	-	65	126	33.8	17	-	80	-	0.64
Coil												
Cable coil									49	-	46	-
DIN plug coil									64	-	47	-
Terminal box coil 10 W									72	-	47	-
Terminal box coil 12 / 20 W									80	-	68	-

⁽¹⁾ Net weight of coil for 10 W is approx. 0.3 kg and for 12 and 20 W is approx. 0.5 kg. The Weight of flange set is 0.6 kg

For 3D CAD models on individual code numbers visit store.danfoss.com

Dimensions and weights for EVR 20 Flange connection

Figure: EVR and Cable coil

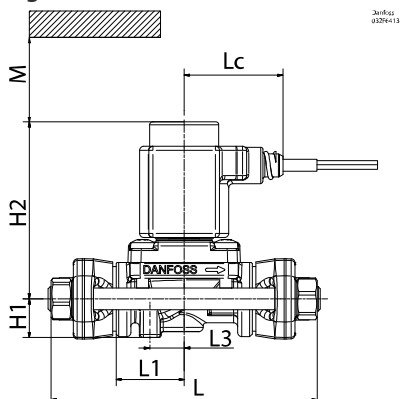

Figure: EVR and DIN plug coil

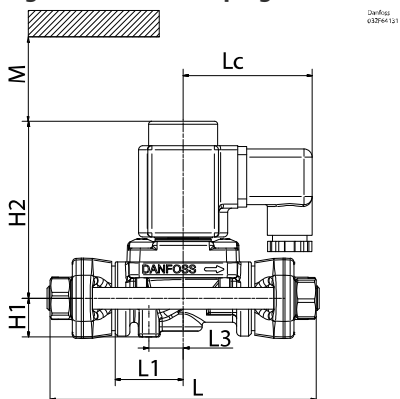

Figure: EVR and Terminal box coil

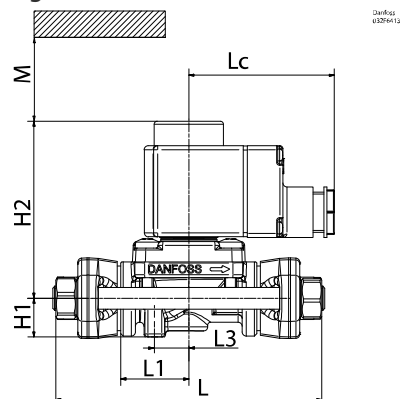

Figure: Manual stem

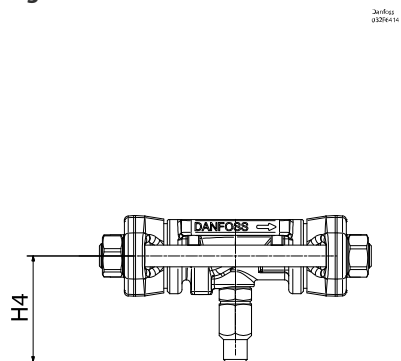

Figure: End view

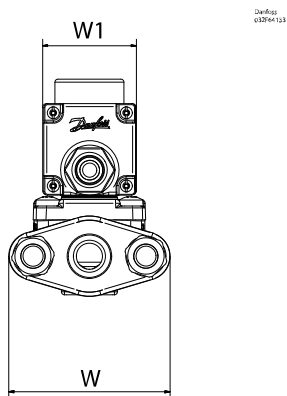

Table: Dimensions and weights for EVR 20 Flange connection

Type	Manual operation	H1	H2	H4	M min.	L	L1	L3	Lc	W	W1 max.	Net weight without coil ⁽¹⁾ [kg]
		[mm]	[mm]	[mm]	[mm]	[mm]	[mm]	[mm]	[mm]	[mm]	[mm]	
Valve body												
EVR 20	Yes	19	93	56	65	156	42.5	20	-	96	-	1.20
	No	19	93	-	65	156	42.5	20	-	96	-	1.20
Coil												
Cable coil									49	-	46	-
DIN plug coil									64	-	47	-
Terminal box coil 10 W									72	-	47	-
Terminal box coil 12 / 20 W									80	-	68	-

⁽¹⁾ Net weight of coil for 10 W is approx. 0.3 kg and for 12 and 20 W is approx. 0.5 kg. The Weight of flange set is 0.6 kg

For 3D CAD models on individual code numbers visit store.danfoss.com

Certificates, declarations and approvals

The list contains all certificates, declarations, and approvals for this product type. Individual code number may have some or all of these approvals, and certain local approvals may not appear on the list.

When you click on the link you will be directed to the latest version of the 'Declaration of Conformity'. Products developed and sold before this date of issue conform to the directives/standards in force at the time of their sale.

Approval type	Title	Certification body	Approval topic
Mechanical Safety Certificate	UL MH7648	UL - Underwriters Laboratories inc.	
Export Control Declaration	Commercial refrigeration solenoid valves and coils - Other - Polymer, Bronze, Brass and cast iron	Danfoss	
Electrical Safety Certificate	CQC 11002055287	CQC - China Quality Certification Centre	
Manufacturer's Declaration	Danfoss MD 033F0695.AA	Danfoss	China RoHS
Manufacturer's Declaration	Danfoss MD 033F4006 AC	Danfoss	China RoHS
EU Declaration	Danfoss EU 033F0685.AZ	Danfoss	Pressure, EMC, PED
Pressure Safety Certificate	LLC CDC EURO-TYSK UA.TR.089.1015.02-22	LLC CDC EURO TYSK - Ukraine	Pressure, PED
Manufacturer's Declaration	Danfoss MD 033F1035.AR	Danfoss	Pressure, PED
Manufacturer's Declaration	Danfoss MD 033F0687.AI	Danfoss	EU RoHS
EU Declaration	Danfoss EU 033F0688.AK	Danfoss	LVD, EMC

Contact details

Online support

Danfoss offers a wide range of support along with our products, including digital information, software, mobile apps and expert guidance. See the possibilities below.



The Danfoss Design center

Discover the Design Center, our advanced digital platform that streamlines product selection. With integrated tools and enhanced type pages, it's simpler than ever to access product information and documentation, and to select the right products. Check the availability of Danfoss products at partner locations and enjoy seamless transitions from selection to purchase with our basket-to-basket functionality. Whether you're buying from our distributors or directly from the Product Store, the Design Center simplifies your experience. Learn more at: designcenter.danfoss.com.



The Danfoss product store

The Danfoss Product Store is a one-stop shop available 24/7 for our customers, no matter where you are in the world or what area of industry you work in. Browse our catalog, check product details and documentation, view your prices and product availability, and quickly finalize your purchase. Start browsing at: store.danfoss.com.



Danfoss Partner Portal/Product Data tool

Designed to support you with easy access to product data extracts, essential resources, tools, and information. The Partner Portal provides a centralized hub for product documentation, training materials, marketing assets, and technical support, ensuring you have everything you need to succeed and grow your business with Danfoss. The Partner Portal is available 24/7 at: partner.danfoss.com and is ready to support your business.



Find technical documentation

Find technical documentation you need to get your project up running. Get direct access to our official collection of data sheets, certificates and declarations, manuals and guides, 3D models and drawings, case stories, brochures, and much more. Start searching now at: documentation.danfoss.com.



Danfoss Learning

Danfoss Learning is a free online learning platform. It features courses and materials specifically designed to help engineers, installers, service technicians, and wholesalers better understand the products, applications industry topics, and trends that will help you do your job better. Find your local Danfoss website here: learning.danfoss.com.



Get local information and support

Local Danfoss websites are the main sources for help and information about our company and products. Find product availability, get the latest regional news, or connect with a nearby expert - all in your own language. Find your local Danfoss website here: danfoss.com.

Danfoss A/S

Climate Solutions . danfoss.com . +45 7488 2222

Any information, including, but not limited to information on selection of product, its application or use, product design, weight, dimensions, capacity or any other technical data in product manuals, catalogues description, advertisements, etc. and whether made available in writing, orally, electronically, online or via download, shall be considered informative, and is only binding if and to the extent, explicit reference is made in a quotation or order confirmation. Danfoss cannot accept any responsibility for possible errors in catalogues, brochures, videos and other material. Danfoss reserves the right to alter its products without notice. This also applies to products ordered but not delivered provided that such alterations can be made without changes to form, fit or function of the products. All trademarks in this material are property of Danfoss A/S or Danfoss group companies. Danfoss and the Danfoss logo are trademarks of Danfoss A/S. All rights reserved.
