



# Thermo. operated water valve

## FJVA

With built-in temperature sensor

## Description

Thermostatic operated water valves are used for the infinite, proportional regulation of flow quantity, depending on the setting and the sensor temperature.

The Danfoss range of thermostatic operated water valves includes a series of industrial products for both cooling and heating regulation. The valves are self-acting, i.e. they operate without the supply of auxiliary energy such as electricity or compressed air.

Because the valves constantly match flow quantity to demand they are especially suitable for temperature regulation.

The required temperature is maintained constant with no overconsumption of: cooling water in cooling systems; hot water or steam in heating systems and thus operating economy is always reasonable.

## Features & benefits

- Self-acting thermostatic operated water valve, which operates without auxiliary energy
- Opens on rising temperature of cooling water
- Valve opening degree is not affected by cooling water pressure differential
- Hand regulation - unique option on the market, which saves installation time
- Regulating range defined for the point at which the valve begins to open

## Applications

FJVA valves are for applications where, because of installation problems, etc., it is desirable to avoid using a capillary tube. This applies mainly where regulation accuracy requirements are more moderate and where an integral bypass can be accepted.

In FJVA the whole bellows element is used as the sensor. The valve reacts to the cooling water temperature and therefore it must always be installed in the return line. Thus, indirect regulation is involved.

To ensure the medium temperature to influence the thermostatic element, when the valve is closed, a by-pass in the valve (see Figure: Valve body with by-pass) provides a constant minimal flow through the valve.

**Figure: Valve body with by-pass**

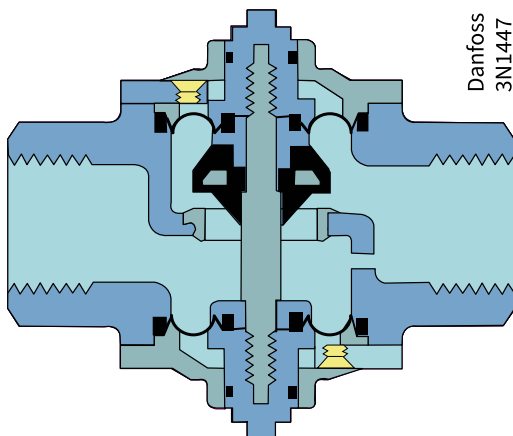

Valves of this type operate with significantly longer time constants than AVTA valves where the sensor is located at the point at which the temperature is to be regulated. FJVA is mainly used in systems where large and sudden load changes do not occur.

## Ordering

### Product code numbers

**Regulation range: 0 – 30 °C**

Media temperature: -25 – 55 °C

Differential pressure: 0 – 10 bar

**Table: Ordering**

Type	$k_v$ value	Bypass <sup>(1)</sup>	Connection	Code no.
FJVA 15	1.9	ø2.0	G ½	003N8210
FJVA 20	3.4	ø2.0	G ¾	003N8244
FJVA 25	5.5	ø2.5	G 1	003N8245

<sup>(1)</sup> Bypass  $k_v$

ø2.0 mm: 0.11 m<sup>3</sup>/h

ø1.5 mm: 0.06 m<sup>3</sup>/h

ø2.5 mm: 0.16 m<sup>3</sup>/h

**Regulation range: 25 – 65 °C**

Media temperature: -25 – 90 °C

Differential pressure: 0 – 10 bar

**Table: Ordering**

Type	$k_v$ value	Bypass <sup>(2)</sup>	Connection	Code no.
FJVA 15	1.9	ø2.0	G ½	003N8211
FJVA 15	1.9	ø1.5	G ½	003N8247
FJVA 20	3.4	ø2.0	G ¾	003N8215
FJVA 25	5.5	ø2.5	G 1	003N8216

<sup>(2)</sup> Bypass  $k_v$

ø2.0 mm: 0.11 m<sup>3</sup>/h

ø1.5 mm: 0.06 m<sup>3</sup>/h

ø2.5 mm: 0.16 m<sup>3</sup>/h

### Accessories code numbers

**Table: Accessories**

	Designation	Description	Code no.
	Mounting bracket	For FJVA	003N0388
	Set of 3 nitrile (NBR) diaphragms sets for mineral oil	For FJVA 10 FJVA 15 FJVA 20 FJVA 25	003N0448
	Plastic hand knob	For FJVA	003N0520

## Spare parts code numbers

Table: Service elements

Temperature range [°C]	Code no.
0 – 30	003N0285
25 – 65	003N0084

## Functions

### How it works:

When the three elements are built together and the valve is installed, the function sequence is as follows:

1. A temperature-dependent pressure - charge vapor pressure - builds up in the sensor.
2. This pressure is transferred to the valve via the bellows and acts as an opening or closing force.
3. The knob on the setting section and the spring exert a force that acts counter to the bellows.
4. When balance is created between the two opposing forces, the valve spindle remains in its position.
5. If the sensor temperature - or the setting - is changed, the point of balance becomes displaced and the valve spindle moves until balance is re-established, or the valve is fully open or closed.
6. On sensor temperature change the flow quantity change is approximately proportional.
7. The illustrations show an FJVA cooling water valve, but the function principle applies to all types of thermostatic valves.

Table: FJVA valves consist of three main elements

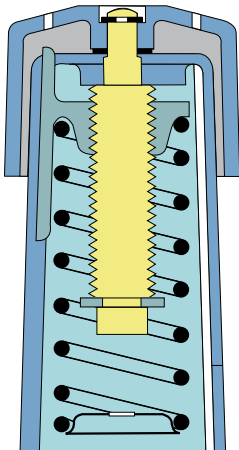
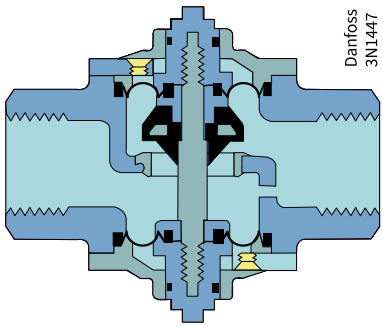
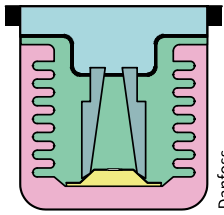
Setting section with knob, reference spring and setting scale.	Valve body with orifice, closing cone and sealing elements.	Sensor in hermetically sealed thermostatic element.
 <p>Danfoss 3N1101</p>	 <p>Danfoss 3N1447</p>	 <p>Danfoss 3N1446</p>

## Product details

### Materials

Figure: Materials connected with FJVA

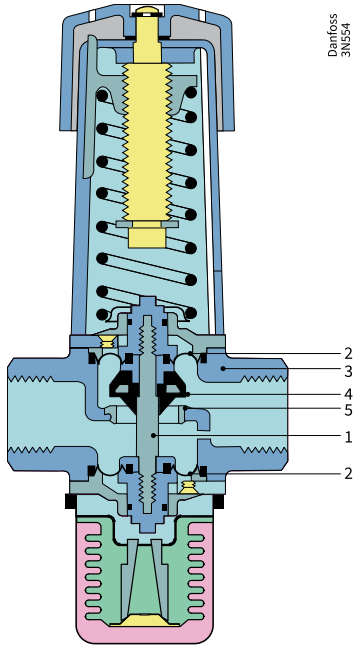

Table: Materials - parts in contact with the medium

No.	Description	Material
1	Spindle	Brass
2	Diaphragms	Rubber - ethylene - propylene (EPDM)
3	Valve body and other metal parts	Forged brass
4	Valve cone	Nitrile rubber (NBR)
5	Valve seat	Stainless steel

### Dimensions

Figure: Dimensions and weights

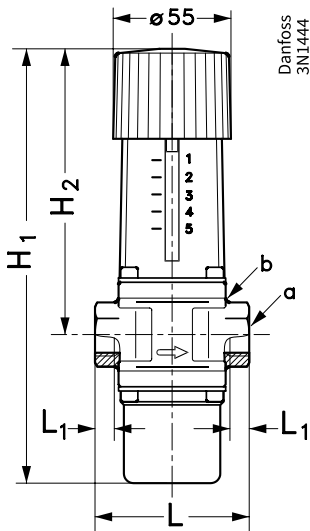
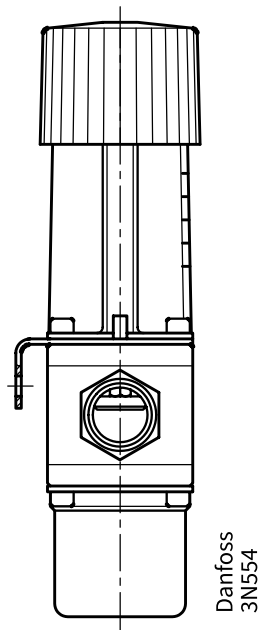

Table: Dimensions and weights

Type	H <sub>1</sub> [mm]	H <sub>2</sub> [mm]	L [mm]	L <sub>1</sub> [mm]	a	b	Net weight [kg]
FJVA 15	205	133	72	14	G ½	27	1.1 – 1.2
FJVA 20	205	133	90	16	G ¾	32	1.2
FJVA 25	215	138	95	19	G 1	41	1.3

## Installation

Figure: FJVA installation



The valves can be installed in any position. An arrow on the valve body indicates the direction of flow. FJVA valves are also marked so that the letters RA can be read straight forwardly. The installation of an FV filter ahead of the valve is recommended.

If a mounting bracket is used (see Spare parts and accessories) it must always be between valve body and setting section (see illustration).

## Sizing

When sizing and selecting thermo. operated water valve, it is most important to ensure that the valve is able to give the necessary quantity of cooling water at any time, irrespective of the load. Therefore, to select a suitable size of valve, it is necessary to know the precise amount of cooling required. On the other hand, to avoid the risk of unstable regulation (hunting), the valve should not be oversized. The type of charge must be selected on the basis of the temperature to be maintained, and on an assessment of the characteristics of each type, as described in the foregoing.

In general the aim should be to select the smallest valve capable of giving the required flow.

### Valve size

The following data are used when selecting valve size:

- Required cooling water flow,  $Q$  [ $\text{m}^3/\text{h}$ ]
- Temperature rise in cooling water,  $\Delta t$  [ $^{\circ}\text{C}$ ]
- Differential pressure across valve,  $\Delta p$  [bar]

With fully open valve the differential pressure should be around 50% of the total pressure drop across the cooling system.

The following diagrams are intended to make valve sizing easier:

- Heating or cooling with water
- Relation between water quantity and pressure drop across valve
- Nomogram showing the valve  $k_v$  range
- Valve flow quantity in fully open position, as a function of pressure drop  $\Delta p$ .

**Figure: Heating or cooling with water**

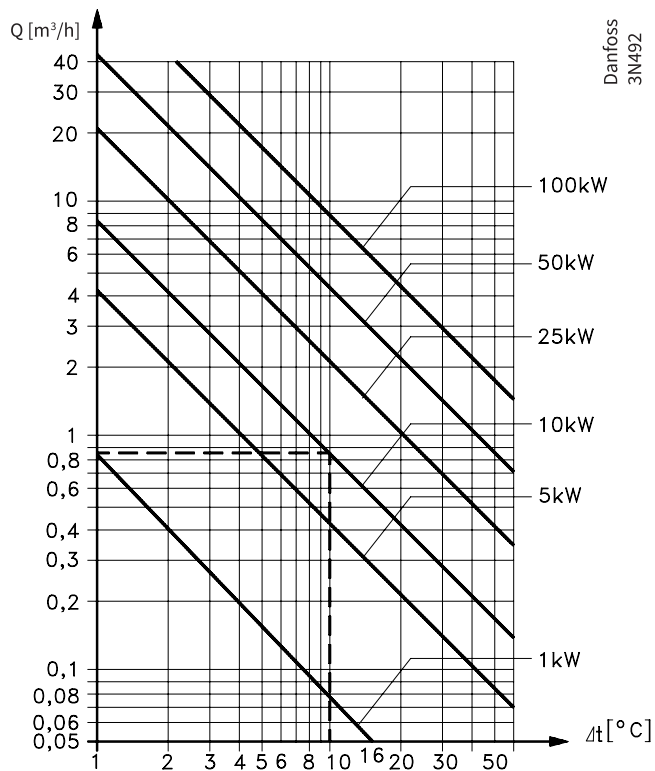

**Example:**

Necessary cooling output 10 kW with  $\Delta t = 10^{\circ}C$

Required flow 0.85  $m^3/h$

**Figure: Relation between water quantity and pressure drop across valve**

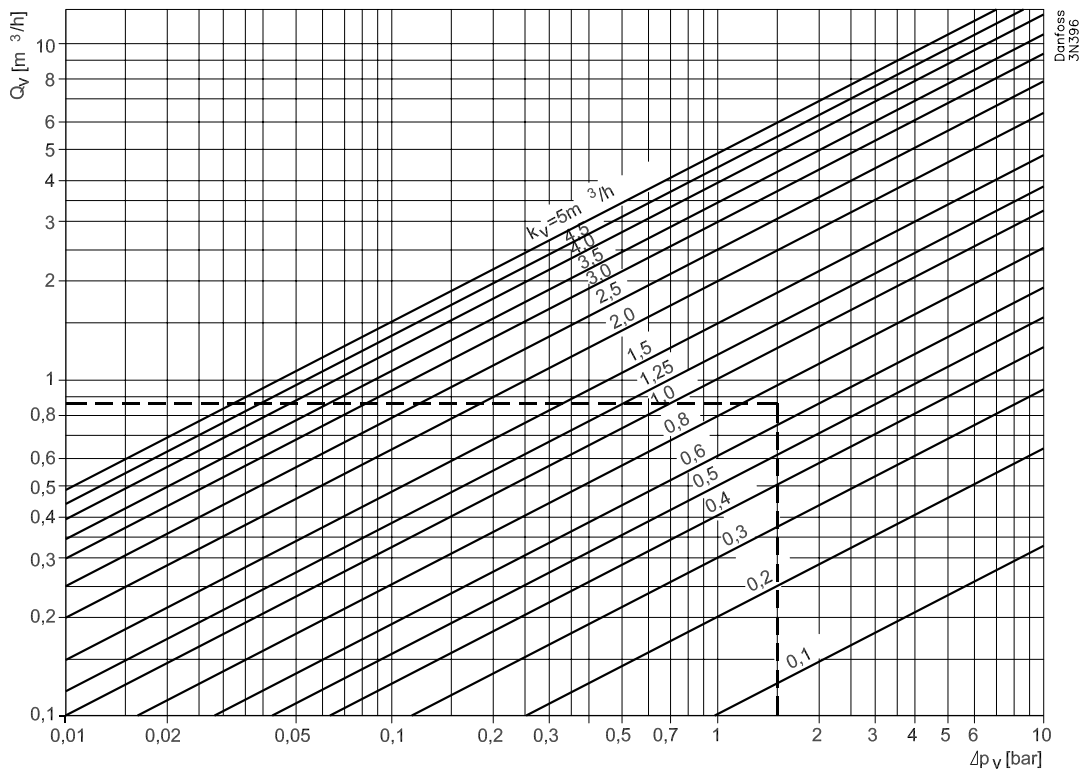

**Example:**

Flow 0.85  $m^3/h$  with a pressure drop of 1.5 bar.

The  $k_v$  value becomes 0.7  $m^3/h$ .

**Figure: Nomogram showing the valve  $k_v$  range**

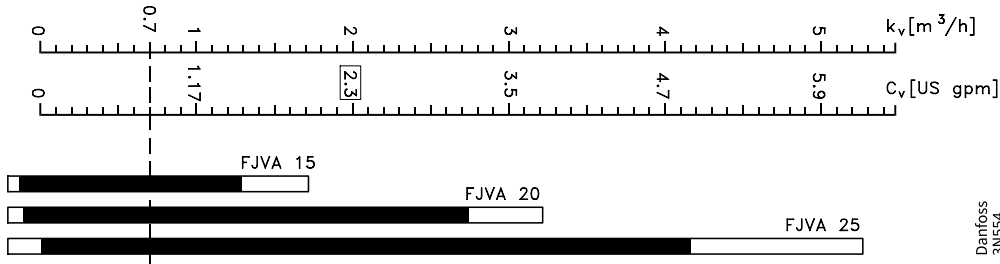

$K_v$  values are always given for water flow in  $[m^3/h]$  with a pressure drop  $\Delta p$  of 1 bar.  
The valve should be selected so that the necessary  $k_v$  value lies in the middle of the regulation range.

**Example:**

FJVA 15 are the most suitable for a  $k_v$  value of 0.7.

**Figure: Valve flow quantity in fully open position, as a function of pressure drop  $\Delta p$ .**

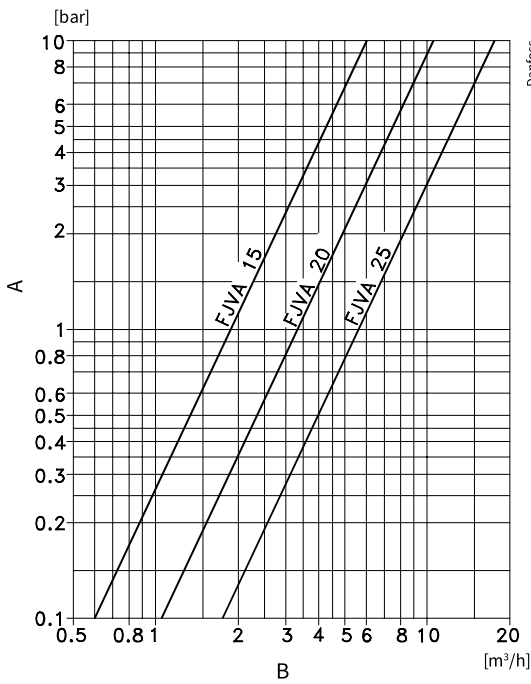

<b>A</b>	Pressure drop across valve
<b>B</b>	Capacity with fully open valve

## Certificates, declarations and approvals

The list contains all certificates, declarations, and approvals for this product type. Individual code number may have some or all of these approvals, and certain local approvals may not appear on the list.

When you click on the link you will be directed to the latest version of the 'Declaration of Conformity'. Products developed and sold before this date of issue conform to the directives/standards in force at the time of their sale.

Approval type	Title	Certification body	Approval topic
Manufacturer's Declaration	<a href="#">Danfoss MD 003N9613.AB</a>	Danfoss	PED, Pressure
Manufacturer's Declaration	<a href="#">Danfoss MD 003N9614.AA</a>	Danfoss	China RoHS
Export Control Declaration	<a href="#">Water regulating valves</a>	Danfoss	
Pressure Safety Certificate	<a href="#">LLC CDC EURO-TYSK</a> <a href="#">UA.TR.089.1015.02-22</a>	LLC CDC EURO TYSK - Ukraine	PED, Pressure

## Contact details

### Online support

Danfoss offers a wide range of support along with our products, including digital information, software, mobile apps and expert guidance. See the possibilities below.



#### The Danfoss Design center

Discover the Design Center, our advanced digital platform that streamlines product selection. With integrated tools and enhanced type pages, it's simpler than ever to access product information and documentation, and to select the right products. Check the availability of Danfoss products at partner locations and enjoy seamless transitions from selection to purchase with our basket-to-basket functionality. Whether you're buying from our distributors or directly from the Product Store, the Design Center simplifies your experience. Learn more at: [designcenter.danfoss.com](https://designcenter.danfoss.com).



#### The Danfoss product store

The Danfoss Product Store is a one-stop shop available 24/7 for our customers, no matter where you are in the world or what area of industry you work in. Browse our catalog, check product details and documentation, view your prices and product availability, and quickly finalize your purchase. Start browsing at: [store.danfoss.com](https://store.danfoss.com).



#### Danfoss Partner Portal/Product Data tool

Designed to support you with easy access to product data extracts, essential resources, tools, and information. The Partner Portal provides a centralized hub for product documentation, training materials, marketing assets, and technical support, ensuring you have everything you need to succeed and grow your business with Danfoss. The Partner Portal is available 24/7 at: [partner.danfoss.com](https://partner.danfoss.com) and is ready to support your business.



#### Find technical documentation

Find technical documentation you need to get your project up running. Get direct access to our official collection of data sheets, certificates and declarations, manuals and guides, 3D models and drawings, case stories, brochures, and much more. Start searching now at: [documentation.danfoss.com](https://documentation.danfoss.com).



#### Danfoss Learning

Danfoss Learning is a free online learning platform. It features courses and materials specifically designed to help engineers, installers, service technicians, and wholesalers better understand the products, applications industry topics, and trends that will help you do your job better. Find your local Danfoss website here: [learning.danfoss.com](https://learning.danfoss.com).



#### Get local information and support

Local Danfoss websites are the main sources for help and information about our company and products. Find product availability, get the latest regional news, or connect with a nearby expert - all in your own language. Find your local Danfoss website here: [danfoss.com](https://danfoss.com).

#### Danfoss A/S

Climate Solutions . danfoss.com . +45 7488 2222

---

Any information, including, but not limited to information on selection of product, its application or use, product design, weight, dimensions, capacity or any other technical data in product manuals, catalogues description, advertisements, etc. and whether made available in writing, orally, electronically, online or via download, shall be considered informative, and is only binding if and to the extent, explicit reference is made in a quotation or order confirmation. Danfoss cannot accept any responsibility for possible errors in catalogues, brochures, videos and other material. Danfoss reserves the right to alter its products without notice. This also applies to products ordered but not delivered provided that such alterations can be made without changes to form, fit or function of the products. All trademarks in this material are property of Danfoss A/S or Danfoss group companies. Danfoss and the Danfoss logo are trademarks of Danfoss A/S. All rights reserved.

---