

Shut-off ball valve

Type GBCT



009R8519

009R8519

Refrigerant: R744 (CO2)
Temperature range (TS): -40 °C – 149 °C / -40 °F – 300 °F
Max. working pressure (PS/MWP): 140 bar / 2031 psig

CAUTION - RISK OF HIGH PRESSURE

This component shall be installed along with a pressure relief valve set to discharge at no higher than the rated pressure of this component. This component is intended for systems in which the critical pressure of the refrigerant will be exceeded. The relief valve shall comply with the requirements of ASME Section VIII, be marked "UV" and sized based on the refrigeration system capacity.

Warning: Applicable to A1, incl. R744, refrigerants as accepted by Danfoss excluding R717 and to noncorrosive gases/liquids dependent on sealing material compatibility. The design pressure shall not be less than the value outlined in Section 9.2 of ANSI/ASHRAE 15 for the refrigerant used in the system. Only authorized persons are allowed to operate this valve, as closing can cause build-up of excessive pressure in the system. For the application use with R744 as part of a secondary loop or cascade system should refer to the datasheet for more attentions.

Warning: Danfoss recommends that valves are installed so that the HP side is oriented towards the highest pressure side of the system when the valve is in the closed position. The ball valve will only internally seal in closed position when flow direction is from HP to LP.

HIGH PRESSURE SIDE "HP"
 LOW PRESSURE SIDE "LP"

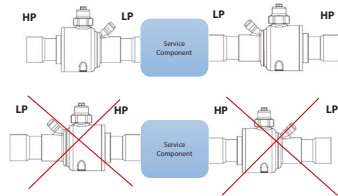

Remove cap and access cap (if present)

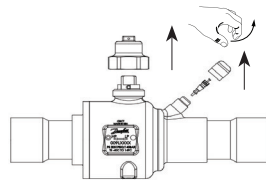

Opening valve

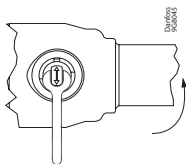

Valve size	Max. Operating Torque	
	Nm	ft-lbs
GBCT 6 - 17	5	4
GBCT 18 - 22	7	5
GBCT 27 - 28	9	7
GBCT 34 - 35	11	8
GBCT 42	15	11
GBCT 48 - 60	34	25

Імпортер: ТОВ з іі "Данфосс ТОВ" 04080, Київ 80, п/с 168, Україна

Info for UK customers only: Danfoss Ltd., 22 Wycombe End, HP9 1NB, GBOR

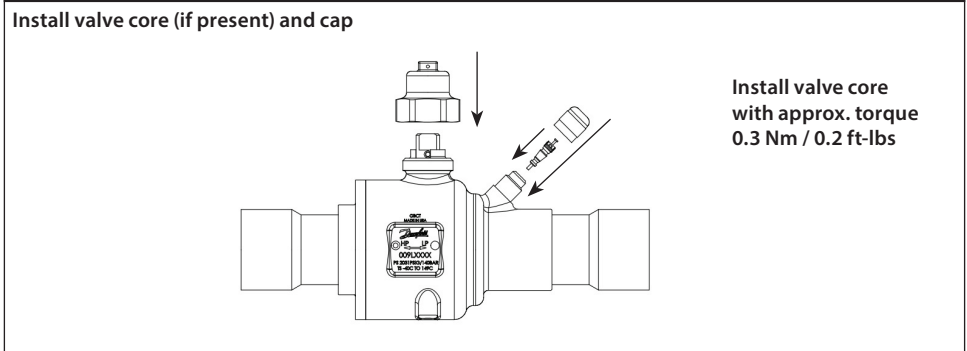
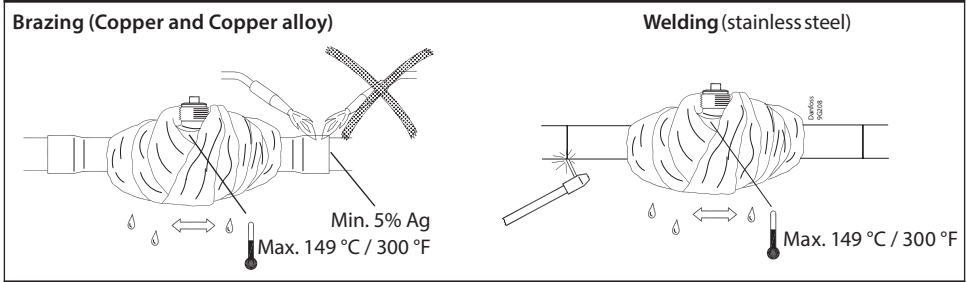
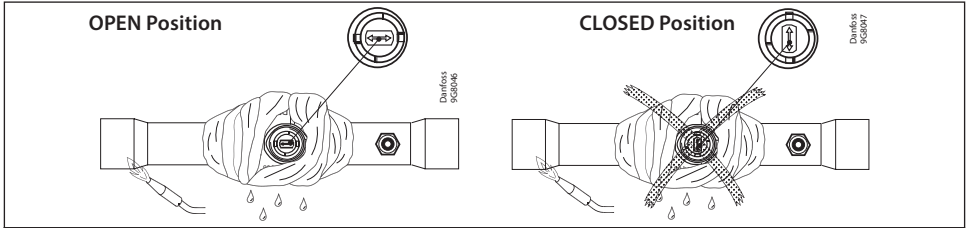

Tighten cap

Tighten the cap with approx. torque

Valve size	Recommended Torque	
	Nm	ft-lbs
GBCT 6 - 17	4-5	3-4
GBCT 18 - 22	7-8	5-6
GBCT 27 - 42	18-20	13-15
GBCT 48 - 60	54-61	40-45

