



Pump

PAHT G 2-308

PAHT G 2.0 - PAHT G 308 ATEX PAHT G 2.0 - PAHT G 308

Description

The Danfoss range of PAHT G high-pressure pumps is specifically designed for use with technical water such as:

- Ultra-pure water that has undergone multiple reverse osmosis processes
- De-ionized water
- Demineralized water

Danfoss PAHT G pumps are positive displacement pumps, with axial pistons that move a fixed amount of water in each cycle. Flow is proportional to the number of input shaft revolutions (rpm). Unlike centrifugal pumps, they produce the same flow at a given speed independently of no matter what the discharge pressure.

The range of PAHT G pumps is based on the standard PAHT pump series. The PAHT G pumps are made with extra coatings that reduce the wear of the pump. This coating is particularly important for pumps used in gas turbine applications or other similar applications where the wear of the pumps is higher due to the ultra pure water quality.

Features & benefits

- Zero risk of lubricant contamination
 - Oil lubricants are replaced with the pumped medium, water, so there is no contamination risk from the pump.
- Low maintenance costs
 - Efficient design and all-stainless steel construction ensure exceptionally long lifetime. When Danfoss specifications are met, service intervals of up to 8,000 hours can be expected. Service is easy, and can be carried out on site due to the simple design and few parts.
- Low energy costs
 - The highly efficient axial piston design provides the lowest energy consumption of any comparable pump on the market.
- Easy installation
 - The lightest and most compact design available.- Pump can be installed horizontally or vertically.
 - - No pulsation dampeners necessary due to extremely low-pressure pulsation.
 - - Powered by electric motors or combustion engines.
 - - Suitable for both boosted inlet pressure and water supply from a tank.
 - - No need for cooling circuits due to very high mechanical efficiency.
- Certified quality
 - ISO 9001, ISO 14001
 - ATEX available
 - API available on request

Ordering

Product code numbers

PAHT G 2-12.5

Pump size		2	3.2	4	6.3	10	12.5
Code number PAHT G		180B1003	180B1004	180B1005	180B1006	180B1007	180B1008
Code number ATEX PAHT G		180B6131	180B6177	180B6130	180B6129	180B6132	180B6133
Housing material		AISI 304	AISI 304	AISI 304	AISI 304	AISI 304	AISI 304
Geometric displacement	cm ³ /rev	2	3.2	4	6.3	10	12.5
	in ³ /rev	0.12	0.20	0.24	0.38	0.61	0.76
Pressure							
Min. outlet pressure	barg	10	10	10	10	10	10
	psig	145	145	145	145	145	145
Max. outlet pressure	barg	100	100	100	100	140	140
	psig	1450	1450	1450	1450	2031	2031
Inlet pressure, continuous	barg	0 – 4	0 – 4	0 – 4	0 – 4	0 – 4	0 – 4
	psig	0 – 58	0 – 58	0 – 58	0 – 58	0 – 58	0 – 58
Max. inlet ¹⁾ pressure, peak	barg	4	4	4	4	4	4
	psig	58	58	58	58	58	58
Speed							
Min. speed	rpm	1000	1000	1000	1000	1000	1000
Min. speed, continuous	rpm	1000	1000	1000	1000	1000	1000
Max. speed	rpm	3000	3000	3000	3000	2400	2400
Typical flow - Flow curves available in section 5							
1000 rpm at max. pressure	l/min	0.7	2.0	3.0	5.5	7.6	10.2
1500 rpm at max. pressure	l/min	1.7	3.6	5.0	8.6	12.6	16.5
1200 rpm at max. pressure	gpm	0.3	0.7	1.0	1.8	2.5	3.3
1800 rpm at max. pressure	gpm	0.6	1.2	1.6	2.7	4.0	5.3
Typical motor size							
1500 rpm at max. pressure	kW 50 Hz	0.75	1.1	1.5	2.2	4.0	5.5
1800 rpm at max. pressure	hp 60 Hz	1.0	1.5	2.0	3.0	7.5	10
Torque at max. outlet pressure	Nm	4.4	6.7	8.1	12.4	25.6	31.7
	lbf-ft	3.2	4.9	6.0	9.2	18.9	23.4
Media temperature	°C	2 – 50	2 – 50	2 – 50	2 – 50	2 – 50	2 – 50
	°F	37 – 122	37 – 122	37 – 122	37 – 122	37 – 122	37 – 122
Ambient temperature	°C	0 – 60	0 – 60	0 – 60	0 – 60	0 – 60	0 – 60
	°F	32 – 140	32 – 140	32 – 140	32 – 140	32 – 140	32 – 140
Sound pressure level ²⁾	dB(A)	76	76	76	76	75	75
Weight	kg	4.4	4.4	4.4	4.4	7.7	7.7
	lbs	9.7	9.7	9.7	9.7	17.0	17.0

¹⁾ 1% per minute peak, 10% per minute during start up.

²⁾ Measurements according to EN ISO 3744: 2010 / dB(A) [L_{PAV 1m}] values are calculated. Measured at max pressure and rpm for a motor pump unit

PAHT G 20-32 and PAHT G 20-32 LP

Pump size		20	20 LP	25	25 LP	32	32 LP
Code number PAHT G		180B1009	180B1044	180B1010	180B1045	180B1011	180B1046
Code number ATEX PAHT G		180B6119	-	180B6120	-	180B6121	-
Housing material		AISI 316 or higher	AISI 316 or higher	AISI 316 or higher	AISI 316 or higher	AISI 316 or higher	AISI 316 or higher
Geometric displacement	cm ³ /rev	20	20	25	25	32	32
	in ³ /rev	1.22	1.22	1.53	1.53	1.95	1.95
Pressure							
Min. outlet pressure	barg	50	10	30	10	30	10
	psig	725	145	435	145	435	145
Max. outlet pressure)	barg	140	50	160	50	160	50
	psig	2030	725	2320	725	2320	725
Inlet pressure, continuous ¹⁾	barg	2 – 7	2 – 6	0 – 6	2 – 6	0 – 6	2 – 6
	psig	29 – 102	29 – 87	0 – 87	29 – 87	0 – 87	29 – 87
Max. inlet pressure, peak ²⁾	barg	15	20	20	20	20	20
	psig	218	290	290	290	290	290
Speed							
Min. speed	rpm	700	700	700	700	700	700
Min. speed, continuous	rpm	1000	1000	1000	1000	1000	1000
Max. speed	rpm	2400	2400	2400	2400	2400	2400
Typical flow - Flow curves available in section 5							
1000 rpm at max pressure	l/min	13.4	17.9	20.6	23	28.0	31.5
1500 rpm at max pressure	l/min	23.1	27.5	33.2	35.3	44.2	47.4
1200 rpm at max. pressure	gpm	4.4	5.7	6.7	7.4	9.0	10.0
1800 rpm at max. pressure	gpm	7.6	8.8	10.6	11.3	14.0	15.1
Typical motor size							
1500 rpm at max. pressure	kW 50Hz	5.5	4	11.0	5.5	15.0	5.5
1800 rpm at max. pressure	hp 60Hz	10	7.5	20.0	7.5	25	10
Torque at max. outlet pressure	Nm	35	19.5	69.2	25	89.0	29
	lbf-ft	25.8	14.4	51.1	18.5	65.7	21.4
Media temperature	°C	2 – 50	2 – 50	2 – 50	2 – 50	2 – 50	2 – 50
	°F	37 – 122	37 – 122	37 – 122	37 – 122	37 – 122	37 – 122
Ambient temperature	°C	0 – 50	0 – 60	0 – 60	0 – 60	0 – 60	0 – 60
	°F	32 – 122	32 – 140	32 – 140	32 – 140	32 – 140	32 – 140
Sound pressure level ³⁾	dB(A)	79	79	79	79	79	79
Weight	kg	19	19	19	19	19	19
	lbs	42	42	42	42	42	42

¹⁾ Above 1800 rpm inlet pressure 2-6 barg

²⁾ 1% per minute peak, 10% per minute during start up.

³⁾ Measurements according to EN ISO 3744: 2010 / dB(A) [L_{PA,1m}] values are calculated. Measured at max pressure and rpm for a motor pump unit

PAHT G 50-90 and PAHT G 70 LP

Pump size		50	63	70	70LP	80	90
Code number PAHT G		180B1012	180B1013	180B1014	180B1017	180B1015	180B1016
Code number ATEX PAHT G		180B6185	180B6186	180B6187	-	180B6188	180B6189
Housing material		AISI 316 or higher	AISI 316 or higher	AISI 316 or higher	AISI 316 or higher	AISI 316 or higher	AISI 316 or higher
Geometric displacement	cm ³ /rev	50	63	70	70	80	90
	in ³ /rev	3.05	3.84	4.27	4.27	4.88	5.49
Pressure							
Min. outlet pressure	barg	30	30	30	10	30	30
	psig	435	435	435	145	435	435
Max. outlet pressure	barg	80	160	160	80	160	160
	psig	1160	2320	2320	1160	2320	2320
Inlet pressure, continuous	barg	0 – 6	0 – 6	0 – 6	2 – 6	0 – 6	0 – 6
	psig	0 – 87	0 – 87	0 – 87	29 – 87	0 – 87	0 – 87
Max. inlet ¹⁾ pressure, peak	barg	20	20	20	20	20	20
	psig	290	290	290	290	290	290
Speed							
Min. speed	rpm	700	700	700	700	700	700
Min. speed, continuous	rpm	1000	1000	1000	1000	1000	1000
Max. speed	rpm	1800	1800	1800	1800	1800	1800
Typical flow - Flow curves available in section 5							
1000 rpm at max. pressure	l/min	43.7	50.5	57.7	67	68.3	77.6
1500 rpm at max. pressure	l/min	68.7	82.1	92.9	101.5	108.5	122.6
1200 rpm at max. pressure	gpm	14.0	16.4	18.7	21.4	21.9	24.9
1800 rpm at max. pressure	gpm	21.8	26.3	29.6	32.3	34.5	38.9
Typical motor size							
1500 rpm at max. pressure	kW 50 Hz	11	30	30	15.5	37	45
1800 rpm at max. pressure	hp 60 Hz	20	50	50	25	60	75
Torque at max. outlet pressure	Nm	68.5	172.6	191.8	97	219.8	246.6
	lbf-ft	50.6	127.4	141.5	71.5	162.2	182.0
Media temperature	°C	2 – 50	2 – 50	2 – 50	2 – 50	2 – 50	2 – 50
	°F	37 – 122	37 – 122	37 – 122	37 – 122	37 – 122	37 – 122
Ambient temperature	°C	0 – 60	0 – 60	0 – 60	0 – 60	0 – 60	0 – 60
	°F	32 – 140	32 – 140	32 – 140	32 – 140	32 – 140	32 – 140
Sound pressure level ²⁾	dB(A)	81	86	86	86	86	86
Weight	kg	34	34	34	34	34	34
	lbs	75	75	75	75	75	75

¹⁾ 1% per minute peak, 10% per minute during start up.

²⁾ Measurements according to EN ISO 3744: 2010 / dB(A) [L_{PA, 1m}] values are calculated. Measured at max pressure and rpm for a motor pump unit.

PAHT G 256-308

Pump size		256	308
Code number PAHT G		180B6090	180B6091
Code number ATEX PAHT G		180B6190	180B6191
Housing material		AISI 316 or higher	AISI 316 or higher
Geometric displacement	cm ³ /rev	256	308
	in ³ /rev	15.6	18.8
Pressure			
Min. outlet pressure	barg	30	30
	psig	435	435
Max. outlet pressure	barg	120	120
	psig	1740	1740
Inlet pressure, continuous	barg	2 – 6	2 – 6
	psig	29 – 87	29 – 87
Max inlet pressure, peak ¹⁾	barg	10	10
	psig	145	145
Speed			
Min. speed	rpm	450	450
Min. speed, continuous	rpm	700	700
Max. speed	rpm	1250	1250
Typical flow - Flow curves available in section 5			
450 rpm at max. pressure	l/min	89.6	107.8
1250 rpm at max. pressure	l/min	294.4	354.2
450 rpm at max. pressure	gpm	23.3	28.0
1250 rpm at max. pressure	gpm	76.5	92.1
Typical motor size			
1000 rpm at max. pressure	kW 50 Hz	75	75
1200 rpm at max. pressure	hp 60 Hz	100	125
Torque at max. outlet pressure	Nm	549.6	661.3
	lbf-ft	405.6	448.0
Media temperature	°C	2-50	2-50
	°F	37 – 122	37 – 122
Ambient temperature	°C	0 – 60	0 – 60
	°F	32 – 140	32 – 140
Sound pressure level ²⁾	dB(A)	82	87
Weight	kg	105	105
	lbs	231	231

¹⁾ 1% per minute peak, 10% per minute during start up.

²⁾ Measurements according to EN ISO 3744: 2010 / dB(A) [L_{PA, 1m}] values are calculated. Measured at max pressure and rpm for a motor pump unit.

Overview

System architecture

Below sectional drawing is an example of a PAHT G pump.

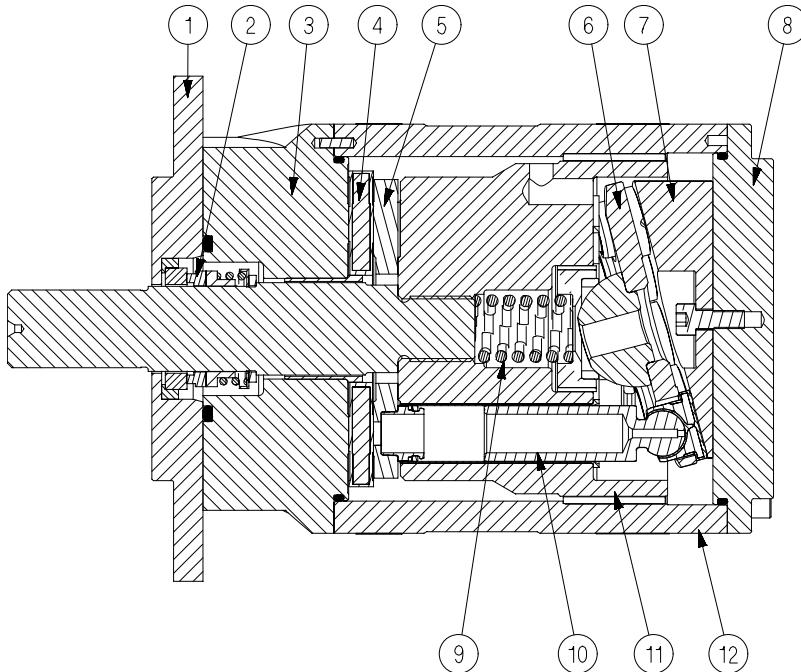

1. Mounting flange
2. Shaft seal
3. Connecting flange
4. Port plate
5. Valve plate
6. Retainer plate
7. Swash plate
8. End cap
9. Spring
10. Piston
11. Cylinder barrel
12. Housing with bearing

Application examples

- High-pressure cleaning with ultra-pure water, as used in the manufacturing of flat-panel displays and many other electronic products.
- High-pressure cleaning with ultra-pure water, as used in the manufacturing of parts for the automobile industry.
- Adiabatic cooling systems to replace or supplement standard A/C systems in server rooms and factories.
- Humidification in office buildings, electronic component manufacturing, dairies, greenhouses, etc.
- Dust suppression and odor control systems, for example in paper, textile and wood production.
- Reduction of NOx emissions in diesel engines and gas turbines.
- Gas turbine by inlet fogging and fuel wash systems.

Product details

General data

Filtration

Proper filtration is crucial for the performance, maintenance and warranty of your pump.

Protect your pump, and the application in which it is installed, by always ensuring that filtration specifications are met, and by always changing filter cartridges according to schedule.

Since water has very low viscosity, Danfoss PAHT G pumps have been designed with very narrow clearances in order to control internal leakage rates and improve component performance. To minimize wear on the pump, it is therefore essential to filter inlet water properly.

The main filter must have a filtration efficiency of 99.98% at 10 µm. We strongly recommend that you always use precision depth filter cartridges rated 10 µm abs. $\beta_{10} \geq 5,000$.

Please note that we do not recommend bag filters or string-wound filter cartridges, which typically have only 50% filtration efficiency. This means that out of 100,000 particles that enter such filters, 50,000 particles pass right through them; compare this to precision depth filters that are 99.98% efficient, and only allow 20 of the same 100,000 particles to pass through.

For more information on the importance of proper filtration, including explanation of filtration principles, definitions, and guidance on how to select the right filter for your pump, please consult our Filtration information and specifications (Danfoss document number 521B1009).

Noise

Since the pump unit is mounted on a frame, the overall noise level can only be determined for a complete system. To minimize vibrations and noise throughout the system, it is therefore very important to mount the pump unit correctly on a frame with dampers and to use flexible hoses rather than metal pipes where possible.

The noise level is influenced by:

- **Pump speed**
High rpm makes more fluid/structure-borne pulsations/vibrations than low rpm.
- **Discharge pressure**
High pressures make more noise than low pressures.
- **Pump mounting**
Rigid mounting makes more noise than flexible mounting because of the structure-borne vibrations. Be sure to use dampers when mounting.
- **Connections to pump**
Pipes connected directly to the pump make more noise than flexible hoses because of structure-borne vibrations.
- **Variable frequency drives (VFDs)**
Motors regulated by VFDs can produce more noise if the VFD does not have the right settings.

Open-system design

1. Inlet line

Dimension the inlet line to obtain minimum pressure loss (large flow, minimum pipe length, minimum number of bends/connections, fittings with small pressure losses and restrictions).

2. Inlet filter

Install the inlet filter (1) in front of the PAHT G pump (2). Please consult the Danfoss filter data sheet for guidance on how to select the right filter.

3. Monitoring pressure switch

Install the monitoring pressure switch (3) between the filter and the pump inlet. Set the minimum inlet pressure according to specifications described in item 4, technical data. The monitoring pressure switch stops the pump if inlet pressure is lower than the set minimum pressure.

4. Monitoring temperature switch

Install the monitoring temperature switch (4) between the filter and the pump, on either side of the monitoring pressure switch. Set the temperature value according to technical data, item 4. The monitoring temperature switch stops the pump if inlet temperature is higher than the set value.

5. Hoses

Always use flexible hoses (5) to minimize vibrations and noise.

6. Inlet pressure

In order to eliminate the risk of cavitation and other pump damage, pump inlet pressure must be maintained according to specifications described in item 4, technical data.

7. Non-return valve (6)

Should be installed after the outlet to prevent pump backspin, which may ruin the pump.

8. Pressure relief valve

As the Danfoss PAHT G pump begins to create pressure and flow immediately after start-up regardless of any counter pressure, a pressure relief valve (7) should be installed to prevent system damage.

Note: If a non-return valve is mounted in the inlet line, a low-pressure relief valve is also recommended between the non-return valve (8) and the pump to protect against high-pressure peaks

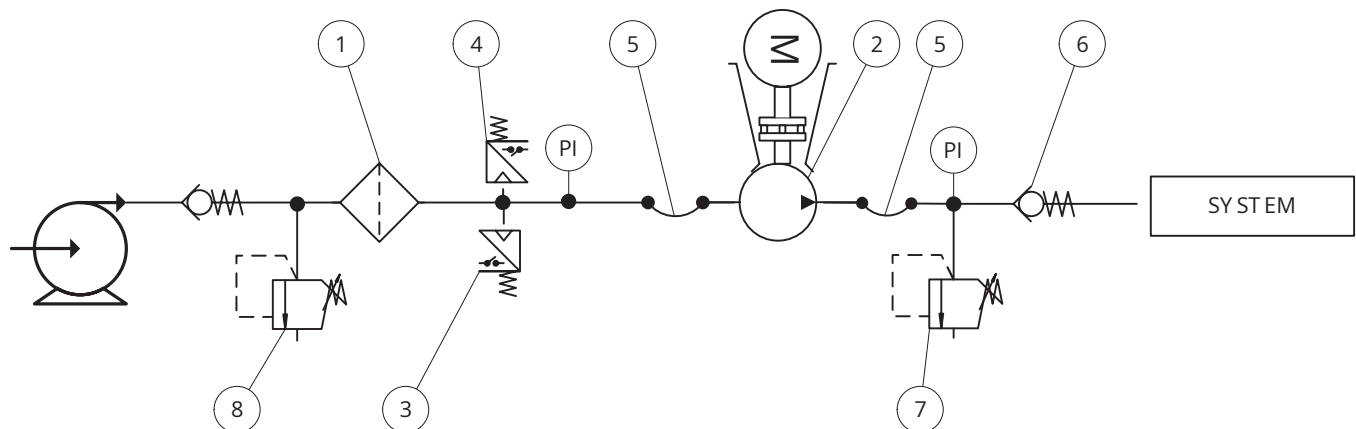

Closed-system design (not applicable for PAHT G 256-308)

1. Inlet line

Dimension the inlet line to obtain minimum pressure loss (large flow, minimum pipe length, minimum number of bends/connections, fittings with small pressure losses and restrictions).

2. Inlet filter

Install the filter (1) in front of the tank (2). Please consult the Danfoss filter data sheet for guidance on how to select the right filter.

3. Monitoring pressure switch

Install the monitoring pressure switch (3) in front of the filter (1). Set the maximum inlet pressure to 2 barg (29.0 psig). The monitoring pressure switch will stop the pump (5) if inlet pressure is higher than 2 barg (29.0 psig), indicating that the filter element must be changed.

4. Monitoring temperature switch:

Install the monitoring temperature switch (4) in the tank. Set the temperature value according to technical data, item 4. The monitoring temperature stops the pump if inlet temperature is higher than the set value.

5. Hoses

Always use flexible hoses (6) to minimize vibrations and noise.

6. Inlet pressure

In order to eliminate the risk of cavitation and other pump damage, pump inlet pressure must be maintained according to specifications described in item 4, technical data.

7. Non-return valve (7)

Should be installed after the outlet to prevent pump backspin, which may ruin the pump.

8. Pressure relief valve

As the Danfoss PAHT G pump begins to create pressure and flow immediately after start-up regardless of any counter pressure, a pressure relief valve (8) should be installed to prevent system damage.

9. System water filling

To ensure proper filtration of new water (10) supplied to the system, always use the filling valve (9).

10. Minimum level switch

Install the minimum level switch (11) above the outlet of the reservoir. The level switch must stop the pump if the water in the reservoir is below the switch, which indicates that the reservoir is empty.

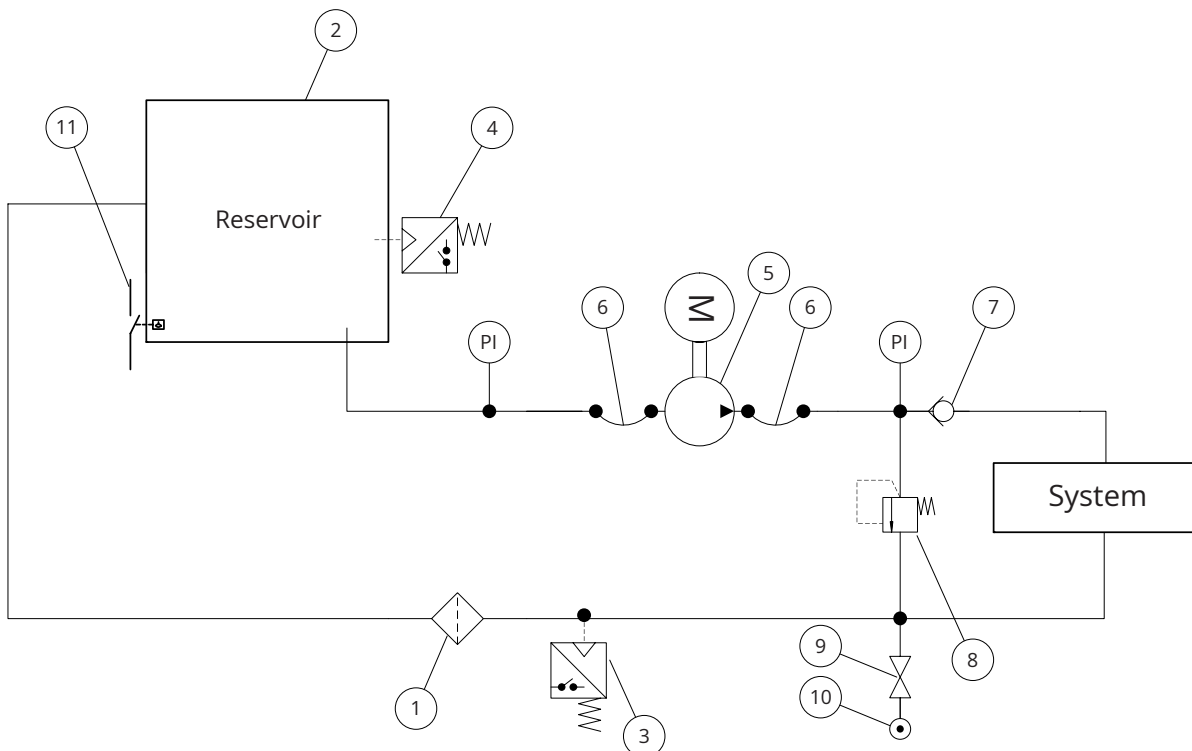

Main functionalities

Motor requirements

The required motor power can be calculated by using the following equation:

$$P = \frac{n \times V \times p}{600.000 \times \eta}$$

P	Power (kW)
M	Torque (Nm)
η	Mechanical efficiency
p	Pressure (barg)
n	Motor speed (rpm)
V	Displacement (cm ³ /rev.)

From the flow curves in item 5, you can determine the rpm of the pump at the desired flow.

The required torque is calculated as follows:

$$M = \frac{V \times p}{62.8 \times \eta}$$

To determine the correct motor size, both the power and torque requirement must be verified.

The mechanical efficiency of the pump, at max pressure, is as follows:

PAHT G 2, 3.2, 4, 6.3	0.8
PAHT G 10, 12.5	0.9
PAHT G 20, 25, 32, 50, 63, 70, 80, 90	0.95
PAHT G 256, 308	0.95

Capacity

The flow (Q_{eff}) at various pressure (p_{max}) can be calculated with the following equation:

$$Q_{\text{eff}} = Q_{(\text{th})} - [(Q_{(\text{th})} - Q(p_{\text{max}})) \times (p / p_{\text{max}})]$$

The theoretical flow can be calculated with the following equation:

$$Q_{(\text{th})} = \frac{V \times n}{1000}$$

At zero pressure the true flow equals the theoretical flow $Q_{(\text{th})}$.

Q_(th)	Theoretical flow (l/min / gpm)
Q (p_{max})	Flows at max. pressure (l/min and gpm)
p_{max}	Max pressure (barg / psig)
p	Pressure (barg / psig)
V	Displacement (cm ³ / rev.)
n	Motor speed (rpm)



PAHT G 2-6.3 typical flow curves at max pressure

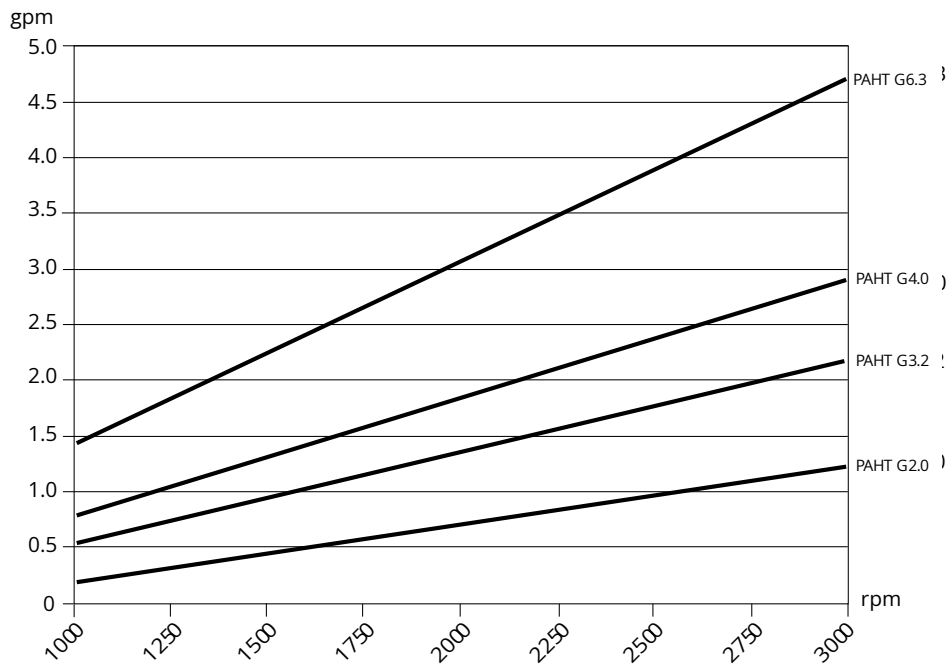
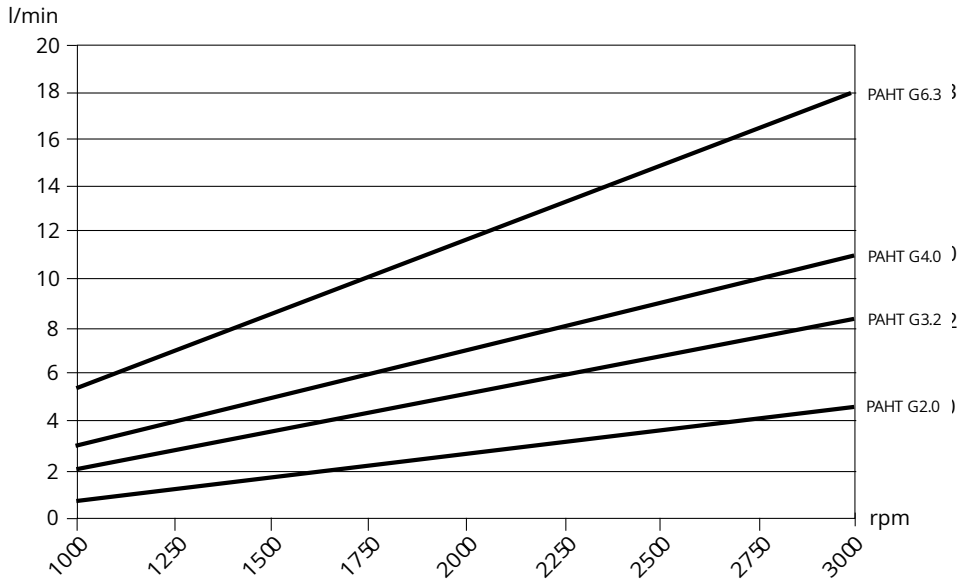



PAHT G 10-12.5 typical flow curves at max pressure

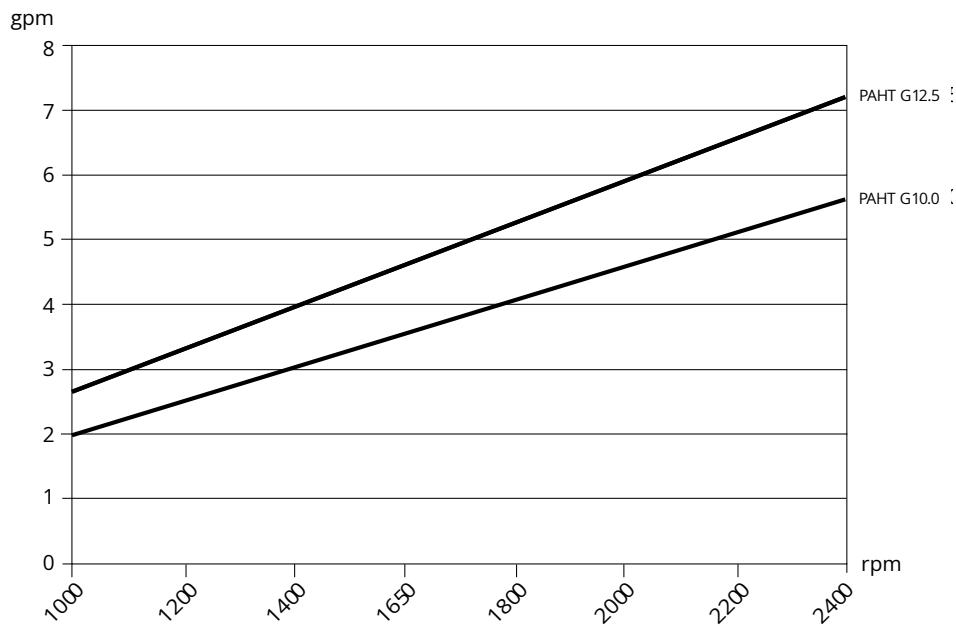
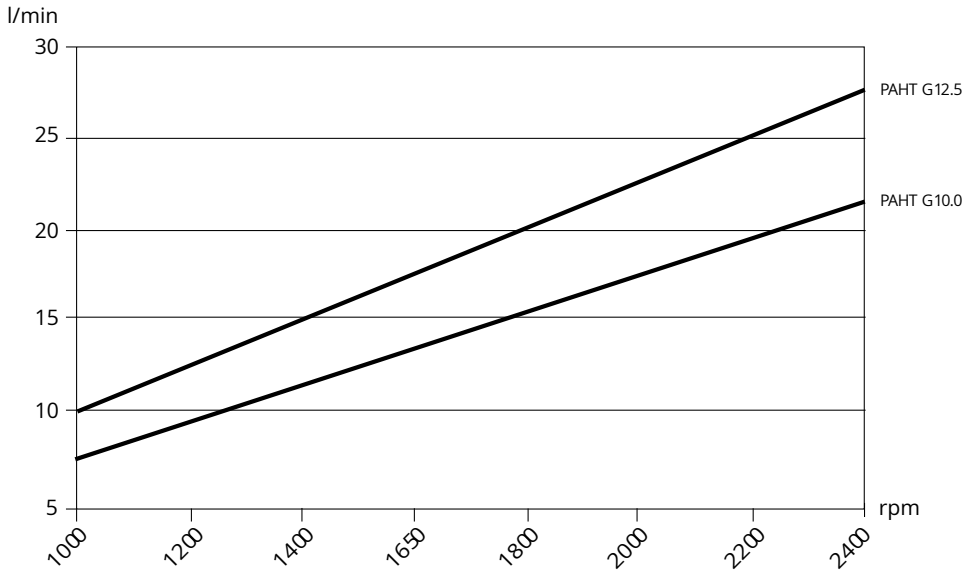



PAHT G 20-32 typical flow curves at max pressure

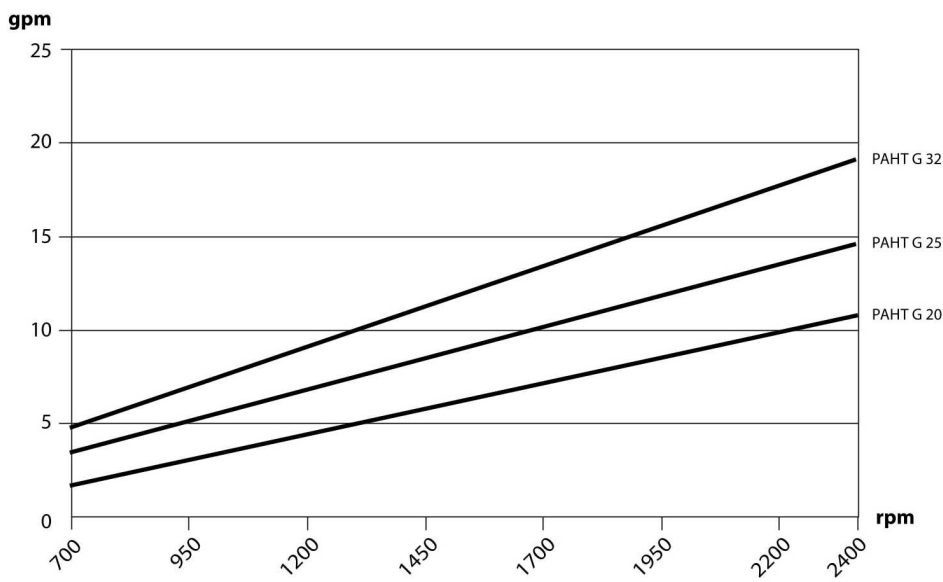
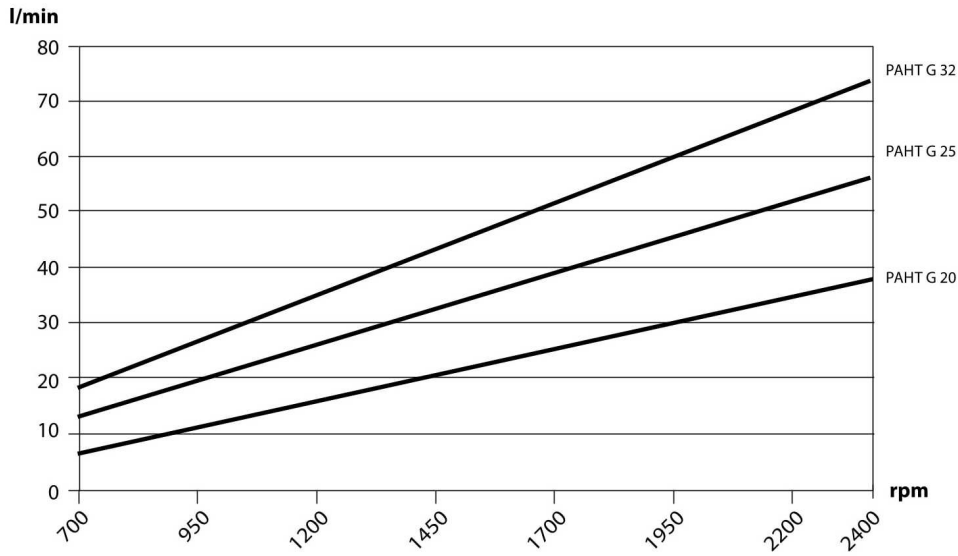



PAHT G 20-32 LP typical flow curves at max pressure

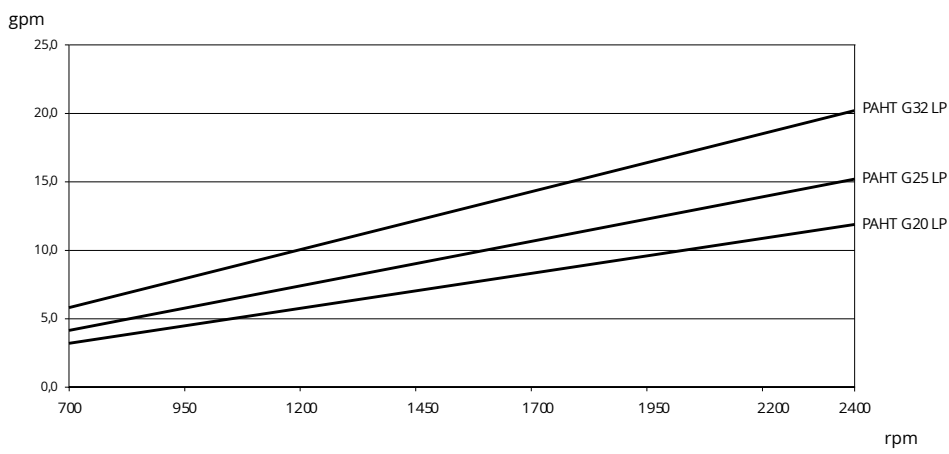
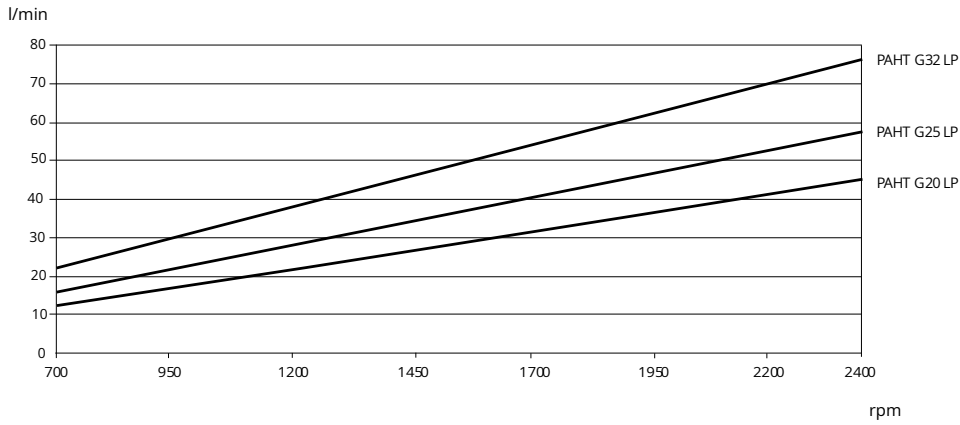



PAHT G 50-90 typical flow curves at max pressure

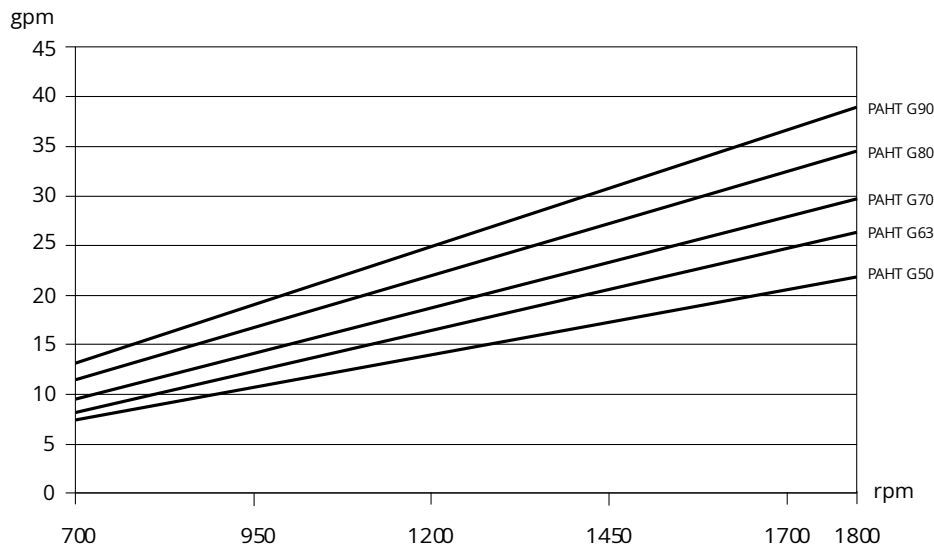
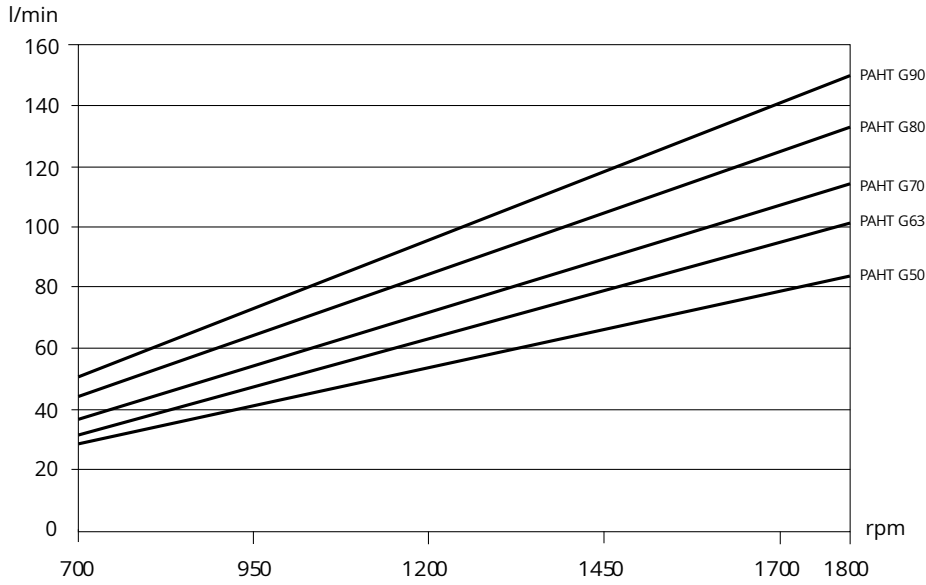



PAHT G 70 LP typical flow curves at max pressure

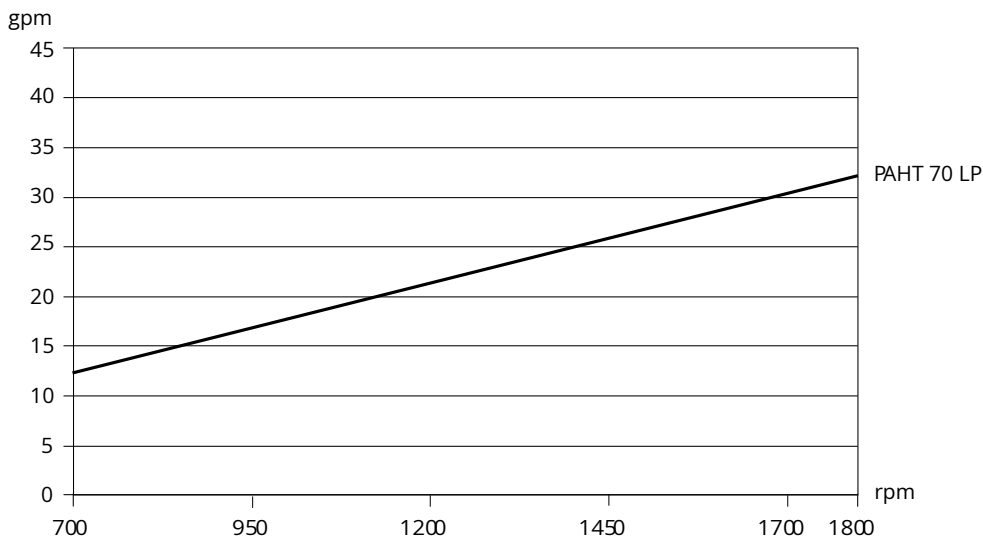
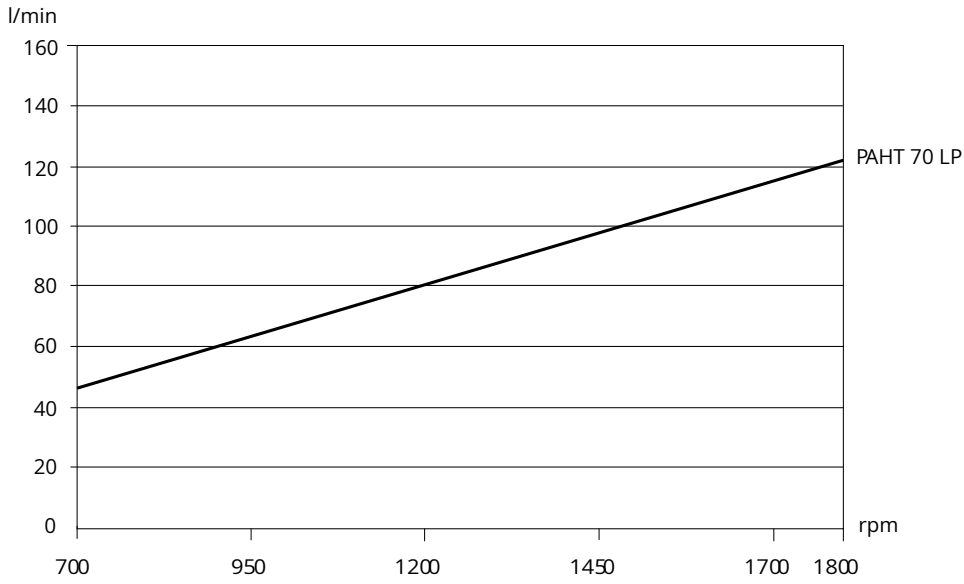



PAHT G 256-308 typical flow curves at max pressure

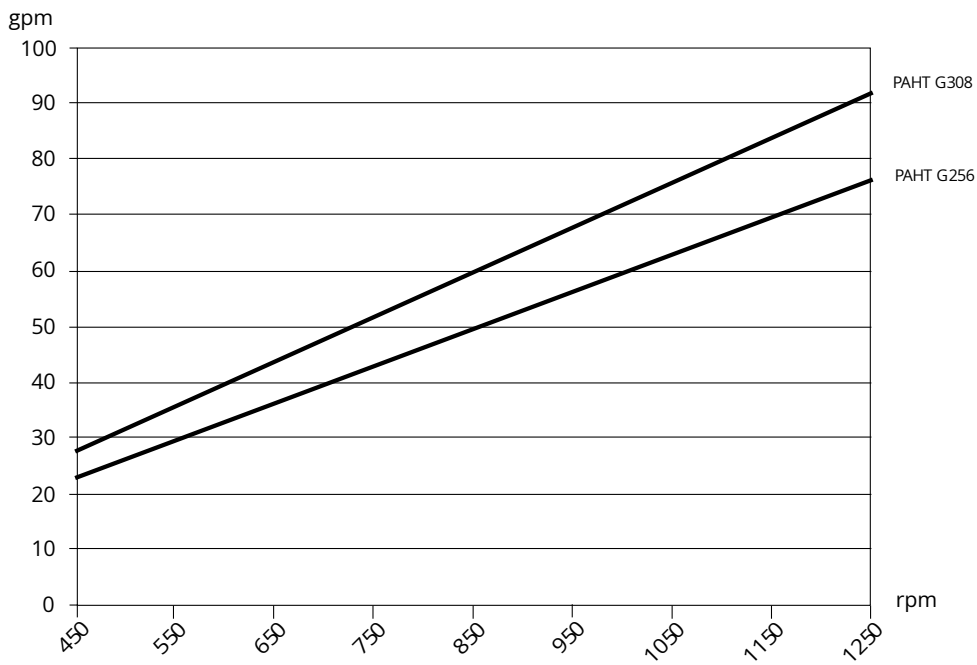
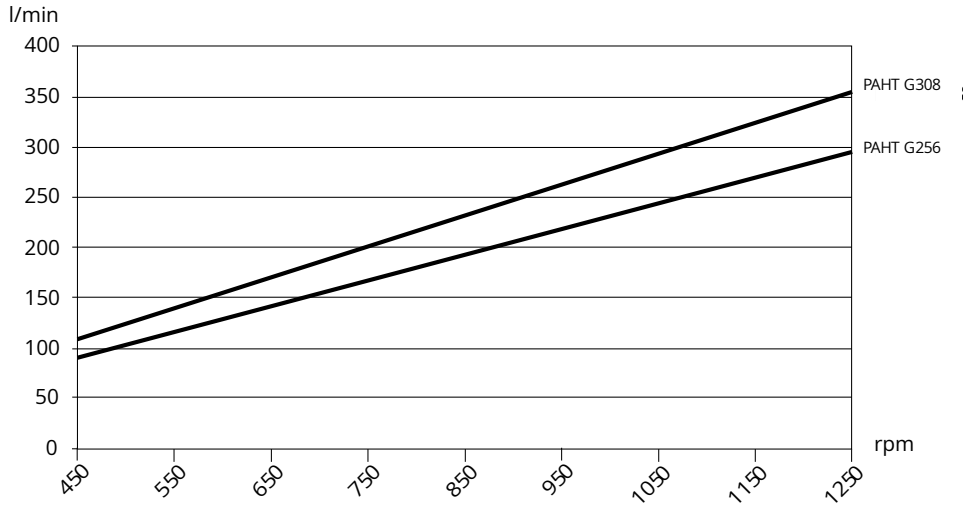

Dimensions

PAHT G 2-6.3

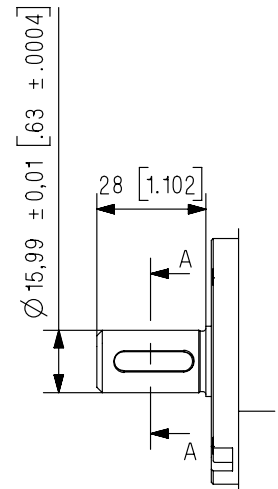
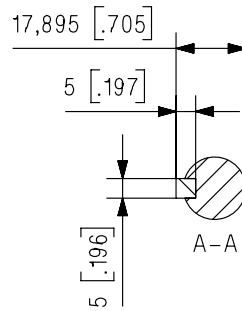
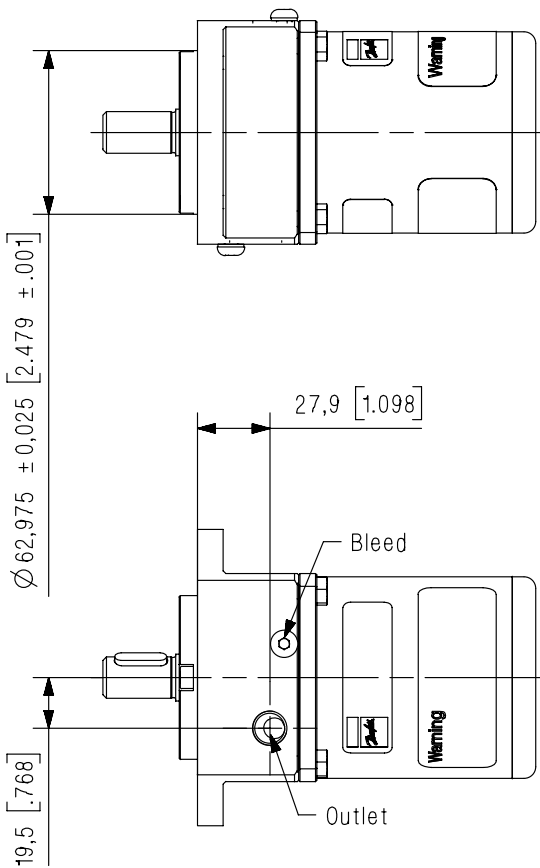
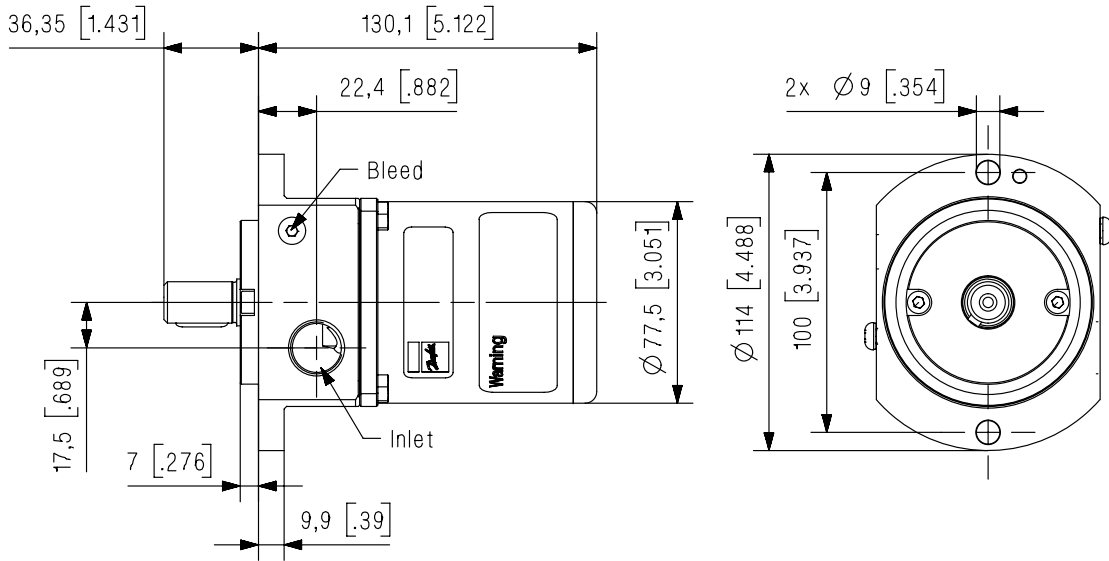

Dimensions without tolerances acc. to ISO 2768-1 designation C.

Description	PAHT/PAHT G 2-6.3
Parallel key, DIN 6885	5 x 5 x 20 mm 0.2 x 0.2 x 0.79 inch
Bleed	M6; hex key 4 mm
Inlet port	G 1/2" BSPP; depth 15 mm
Outlet port	G 1/4" BSPP; depth 11 mm
Mounting flange	ISO 3019-2 63A2HW

PAHT G 10-12.5

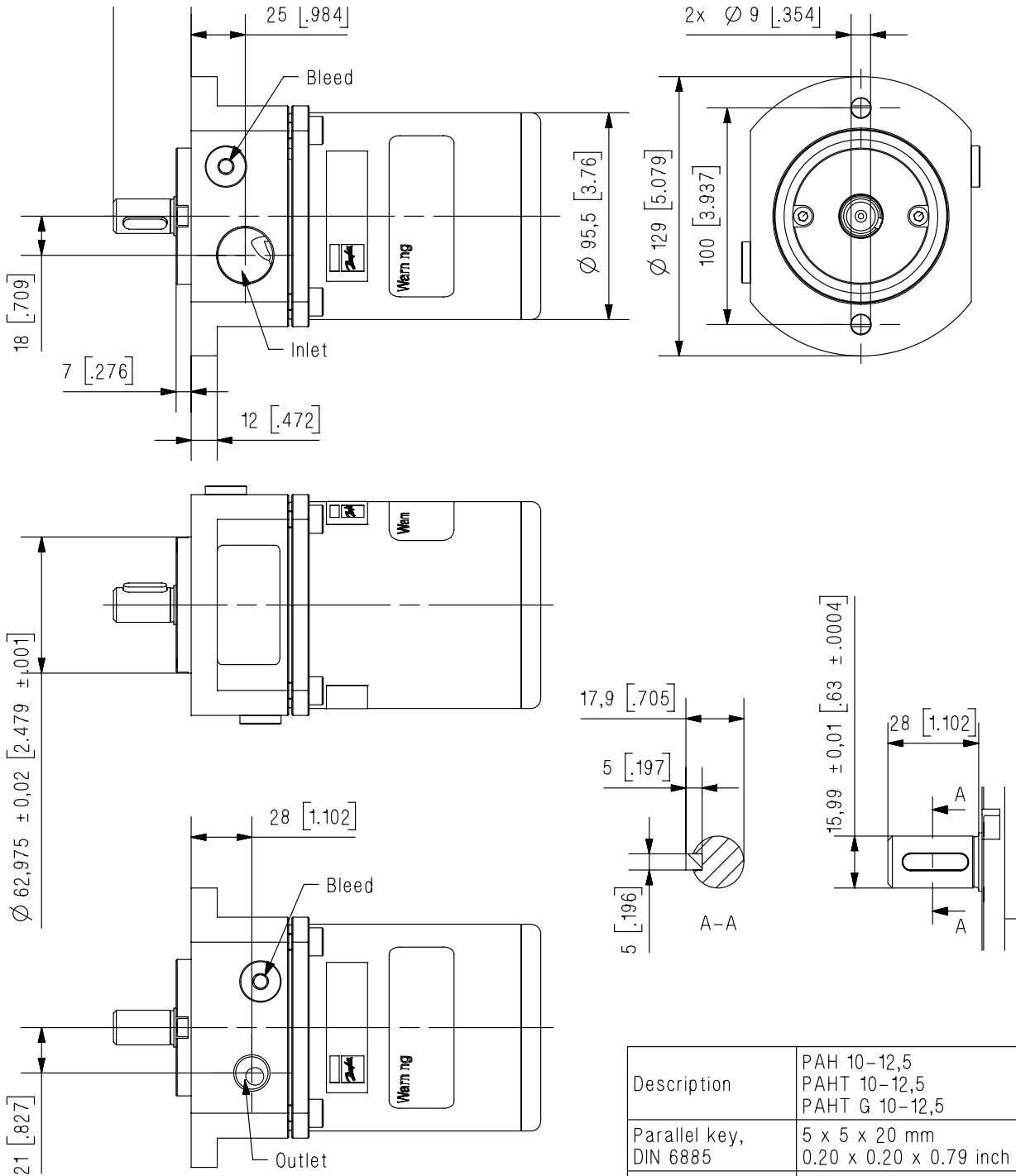

Description	PAH 10-12,5 PAHT 10-12,5 PAHT G 10-12,5
Parallel key, DIN 6885	5 x 5 x 20 mm 0.20 x 0.20 x 0.79 inch
Bleed	G 1/4" BSPP; hex key 6 mm
Inlet port	G 3/4" BSPP; depth 17 mm
Outlet port	G 3/8" BSPP; depth 15 mm
Mounting flange	ISO 3019-2 63A2HW

PAHT G 20-32

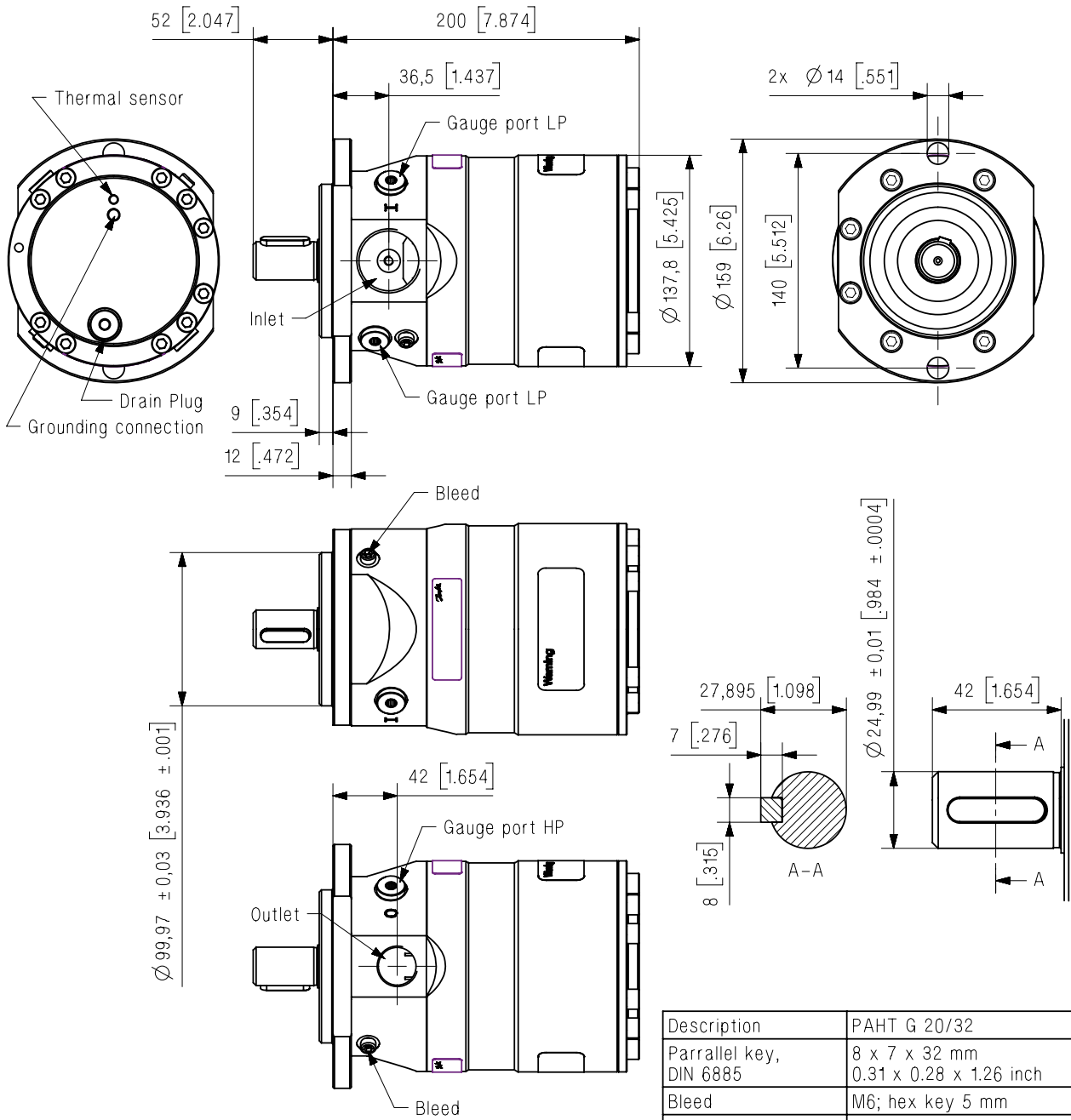

Description	PAHT G 20/32
Parrallel key, DIN 6885	8 x 7 x 32 mm 0.31 x 0.28 x 1.26 inch
Bleed	M6; hex key 5 mm
Inlet port	G 1 1/4" BSPP; depth 20 mm
Outlet port	G 3/4" BSPP; depth 16 mm
Drain Plug	G 1/4" hex key 6mm
Gauge port	G 1/4" BSPP; depth 15 mm
Grounding connection	M8, depth 11 mm
Thermal sensor	M6, depth 11 mm
Mounting flange	ISO 3019-2 100A2HW

PAHT G 50-90

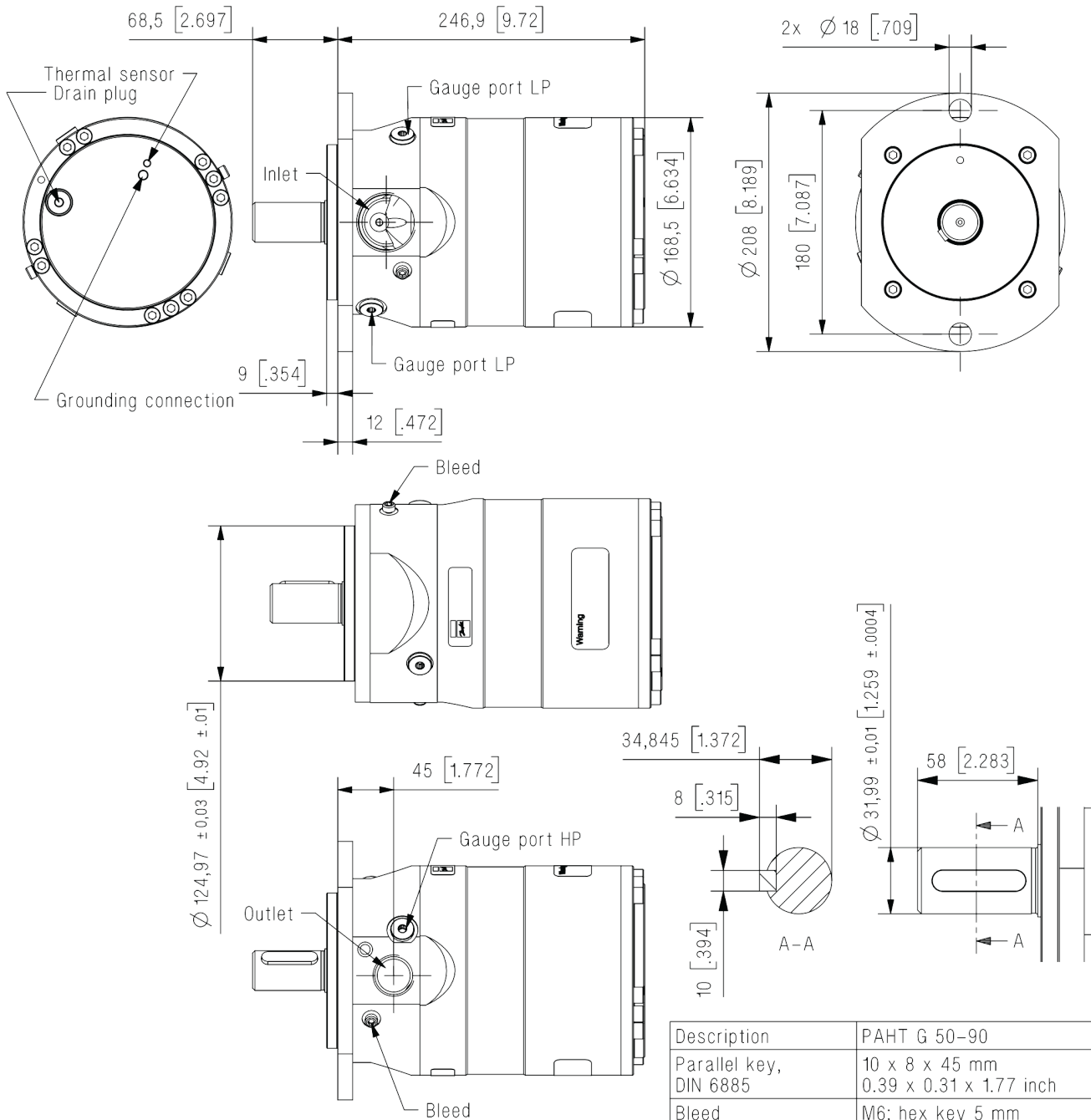

Description	PAHT G 50-90
Parallel key, DIN 6885	10 x 8 x 45 mm 0.39 x 0.31 x 1.77 inch
Bleed	M6; hex key 5 mm
Inlet port	G 1 1/2" BSPP; depth 24 mm
Drain plug	G1/4"; hex key 6 mm
Outlet port	G 1" BSPP; depth 24 mm
Gauge port	G 1/4" BSPP; depth 15 mm
Grounding connection	M8, depth 11 mm
Thermal sensor	M6, depth 11 mm
Mounting flange	ISO 3019-2 125A2HW

Dimensions without tolerances acc. to ISO 2768-1 designation C.

PAHT G 256-308

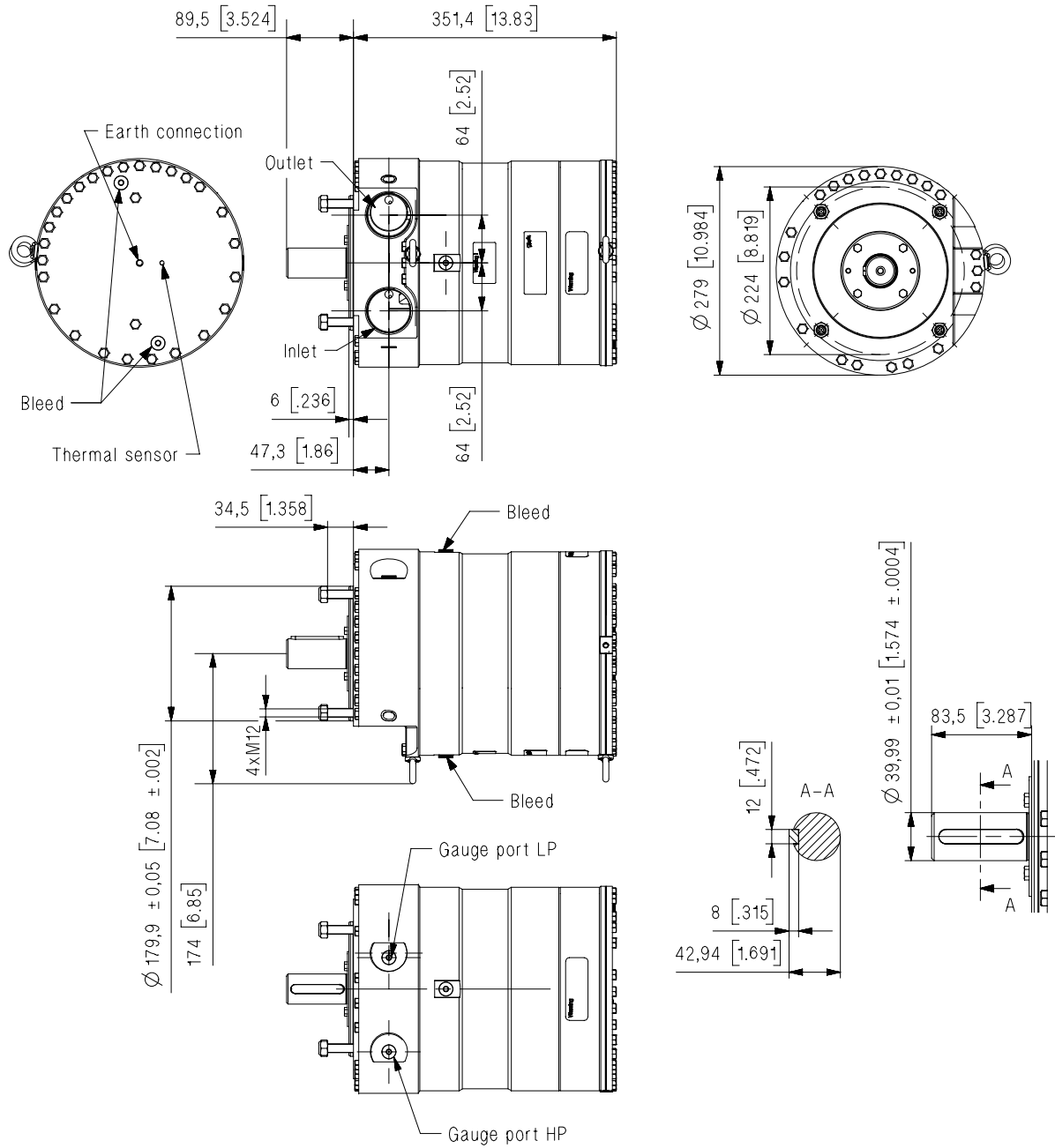

Dimensions without tolerances acc. to ISO 2768-1 designation C.

Description	PAHT/PAHT G 256-308
Parallel key, DIN 6885	12 x 8 x 70 mm 0.47 x 0.31 x 2.76 inch
Bleed	G 1/4"; hex key 6 mm
Inlet port	M60 x 1.5 depth 24 mm
Outlet port	M60 x 1.5 depth 24 mm
Gauge port	G 1/4" BSPP; depth 12 mm
Earth connection	M8, depth 11 mm
Thermal sensor	M6, depth 11 mm
Mounting flange	ISO 3019-2 180B4TW

Installation

See the figure below for instructions on how to mount the pump and connect it to an electric motor or combustion engine.

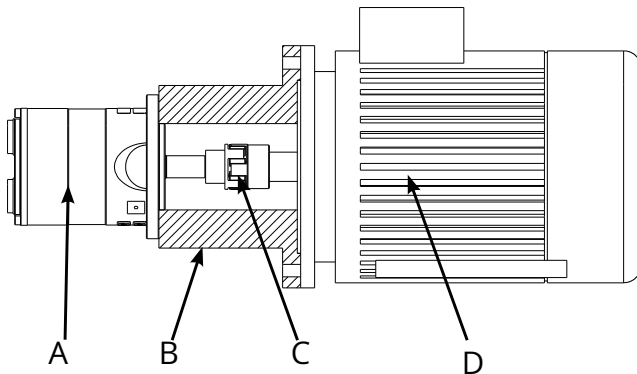

A	Pump
B	Bell housing
C	Coupling
D	Motor

If alternative mounting is required, please contact your Danfoss sales representative for further information.

Note: Do not add any axial or radial loads to the pump shaft.

Service

Danfoss PAHT G pumps are designed for long periods of service-free operation to ensure low maintenance and life cycle costs. Provided that the pump is installed and operated according to Danfoss specifications, Danfoss PAHT G pumps typically run up to 8,000 hours. However, the service schedule for your Danfoss PAHT G pump may vary according to the application and other factors.

The life of a pump may be greatly shortened if Danfoss recommendations concerning system design and operation are not followed.

In our experience, poor filtration is the number one cause of pump damage.

Other factors that affect pump performance and lifetime include:

- running the pump at speeds outside specifications
- supplying the pump with water at temperatures higher than recommended
- running the pump at inlet pressures outside specifications
- running the pump at outlet pressures outside the specifications.

We recommend that you inspect your pump after 8,000 hours of operation even if it is running without any noticeable problems. Replace any worn parts if necessary, including pistons and shaft seals, to keep your pump running efficiently and to prevent breakdown. If worn parts are not replaced, then our guidelines recommend more frequent inspection.

Note: If the recommendations in the manual are not followed, Danfoss reserves the right to void the warranty.

Certificates, declarations and approvals

The list contains all certificates, declarations, and approvals for this product type. Individual code number may have some or all of these approvals, and certain local approvals may not appear on the list.

When you click on the link you will be directed to the latest version of the 'Declaration of Conformity'. Products developed and sold before this date of issue conform to the directives/standards in force at the time of their sale.

Approval type	Title	Certification body	Approval topic
Export Control Declaration	High Pressure pump	Danfoss	
Manufacturer's Declaration	Danfoss MD 180R8305.AE	Danfoss	Pressure, PED
EU Declaration	Danfoss EU 180R8002.AG	Danfoss	MD
Manufacturer's Declaration	Danfoss MD 180R8303.AA	Danfoss	China RoHS
EU Declaration	Danfoss EU 180R8053.AF	Danfoss	MD, ATEX

Contact details

Online support

Danfoss offers a wide range of support along with our products, including digital information, software, mobile apps and expert guidance. See the possibilities below.



The Danfoss Design center

Discover the Design Center, our advanced digital platform that streamlines product selection. With integrated tools and enhanced type pages, it's simpler than ever to access product information and documentation, and to select the right products. Check the availability of Danfoss products at partner locations and enjoy seamless transitions from selection to purchase with our basket-to-basket functionality. Whether you're buying from our distributors or directly from the Product Store, the Design Center simplifies your experience. Learn more at: designcenter.danfoss.com.



The Danfoss product store

The Danfoss Product Store is a one-stop shop available 24/7 for our customers, no matter where you are in the world or what area of industry you work in. Browse our catalog, check product details and documentation, view your prices and product availability, and quickly finalize your purchase. Start browsing at: store.danfoss.com.



Danfoss Partner Portal/Product Data tool

Designed to support you with easy access to product data extracts, essential resources, tools, and information. The Partner Portal provides a centralized hub for product documentation, training materials, marketing assets, and technical support, ensuring you have everything you need to succeed and grow your business with Danfoss. The Partner Portal is available 24/7 at: partner.danfoss.com and is ready to support your business.



Find technical documentation

Find technical documentation you need to get your project up running. Get direct access to our official collection of data sheets, certificates and declarations, manuals and guides, 3D models and drawings, case stories, brochures, and much more. Start searching now at: documentation.danfoss.com.



Danfoss Learning

Danfoss Learning is a free online learning platform. It features courses and materials specifically designed to help engineers, installers, service technicians, and wholesalers better understand the products, applications industry topics, and trends that will help you do your job better. Find your local Danfoss website here: learning.danfoss.com.



Get local information and support

Local Danfoss websites are the main sources for help and information about our company and products. Find product availability, get the latest regional news, or connect with a nearby expert - all in your own language. Find your local Danfoss website here: danfoss.com.

Danfoss A/S

Climate Solutions . danfoss.com . +45 7488 2222

Any information, including, but not limited to information on selection of product, its application or use, product design, weight, dimensions, capacity or any other technical data in product manuals, catalogues description, advertisements, etc. and whether made available in writing, orally, electronically, online or via download, shall be considered informative, and is only binding if and to the extent, explicit reference is made in a quotation or order confirmation. Danfoss cannot accept any responsibility for possible errors in catalogues, brochures, videos and other material. Danfoss reserves the right to alter its products without notice. This also applies to products ordered but not delivered provided that such alterations can be made without changes to form, fit or function of the products. All trademarks in this material are property of Danfoss A/S or Danfoss group companies. Danfoss and the Danfoss logo are trademarks of Danfoss A/S. All rights reserved.
