

Service guide

Energy Recovery Device

iSave 50-70

Disassembling and assembling



Table of Contents

| | | |
|------|--|----|
| 1. | Introduction | 2 |
| 2. | Disassembling vertical base frame | 3 |
| 3. | Disassembling horizontal base frame | 6 |
| 4. | Disconnect the iSave from the electric motor | 10 |
| 5. | Disassembling the booster / vane pump | 11 |
| 6. | Disassembling the pressure exchanger | 19 |
| 7. | Assembling the pressure exchanger..... | 23 |
| 8. | Assembling the booster/vane pump..... | 24 |
| 9. | Continue assembling the pressure exchanger..... | 25 |
| 10. | Continue assembling the booster/vane pump | 27 |
| 11. | Exploded view iSave 50-70..... | 32 |
| 12. | iSave on baseplate, horizontal | 33 |
| 13. | iSave on base frame, vertical..... | 34 |
| 13.1 | iSave on base frame, vertical cont. | 35 |

1. Introduction

This document illustrates instructions for disassembling and assembling the iSave 50-70.

To understand the design of the iSave, see exploded view on page 25.

Remove all hoses or pipes from the iSave connectors by loosening the Victaulic connections and disconnect the electrical cables (only needed for the vertical version.)

Always use suitable lifting equipment.

Important!
It is essential that the iSave is serviced in conditions of absolute cleanliness.

Tools needed to disassemble the iSave:

Parts included in tool set (180F4140):

- Back-up ring tool
- Bushing for valve plate
- M6 and M8 screws
- M6 and M16 washer
- Nut M6
- M8 lifting eye
- Shaft seal tool
- 24 mm crow foot socket
- 19 mm socket
- 3/8" extension
- 3/8" torque wrench
- 4 mm allen key
- Screwdrivers
- 6 mm, 10 mm and 16mm hex socket
- Nylon hammer
- 10 mm fork wrench
- Feeler gauge
- Service instruction

Parts not included in tool set:

- Puller for coupling.
- 2 x M5 screws

To prevent cold welding, Danfoss recommend only to use a food grade lubricants for all screw threads for assembling the iSave (here after only referred to as lubricate) and first tighten the screws by hand.



- The weight of the iSave, including a 18.5 kW IEC electric motor and base frame, is about 462 kg (1020 lb) dry.
- The weight of the iSave alone dry is about 164 kg (362 lb).



2. Disassembling vertical base frame

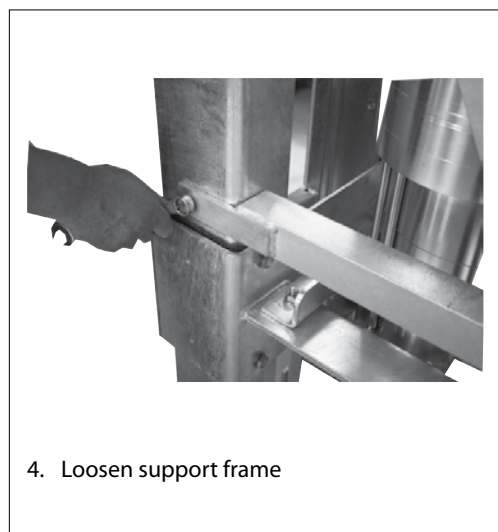

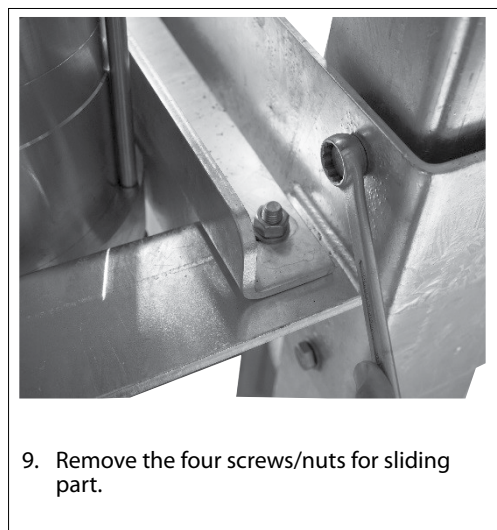
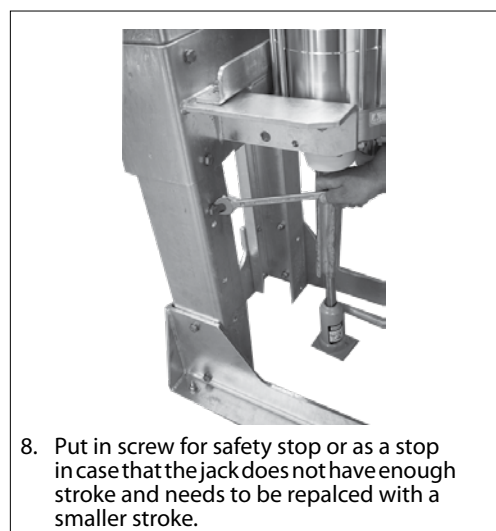
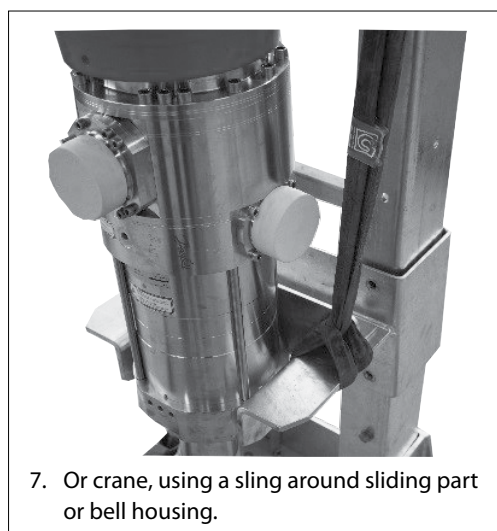
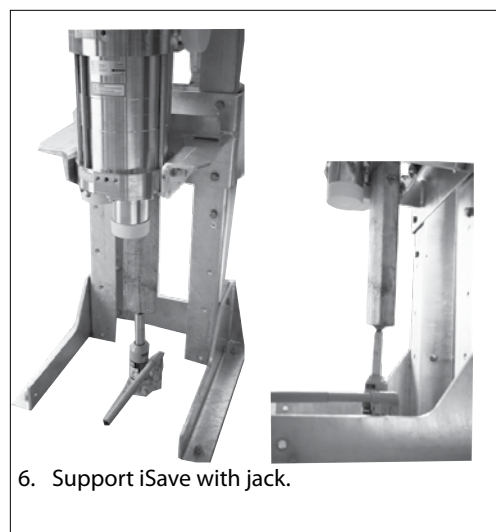
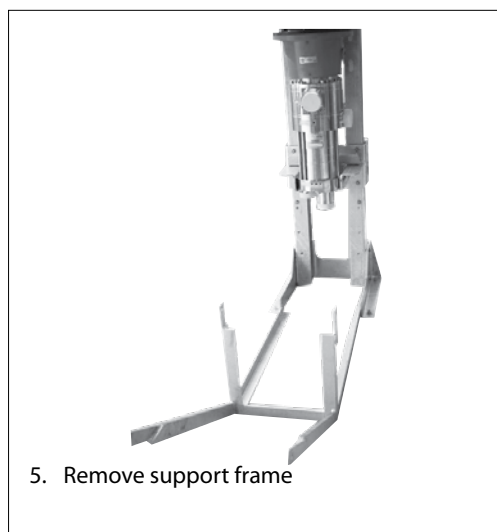

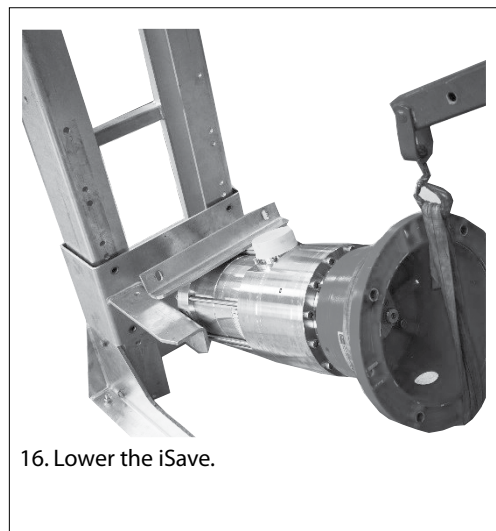
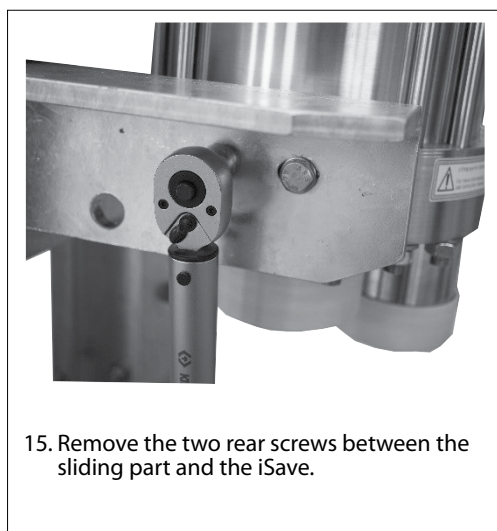
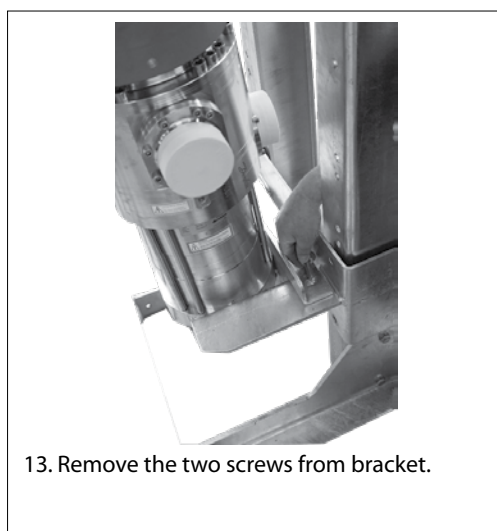
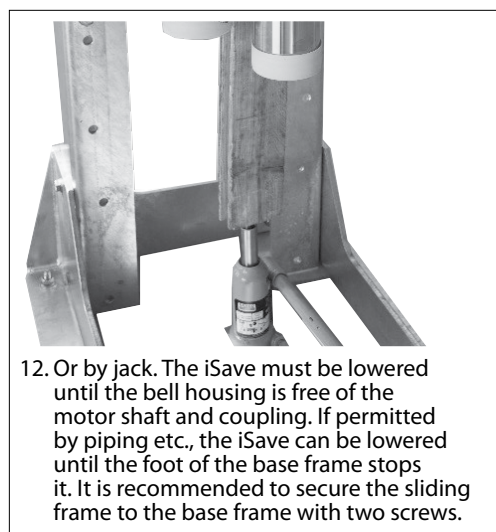
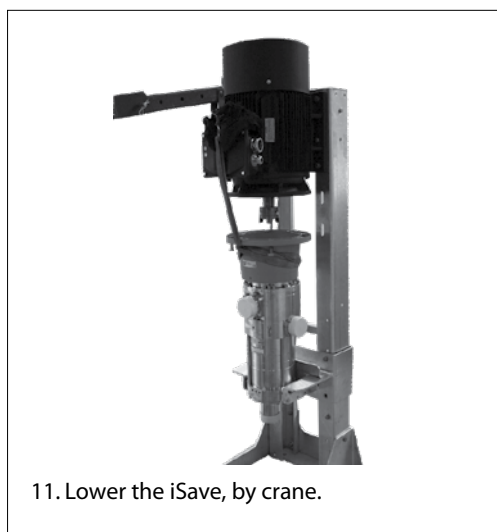

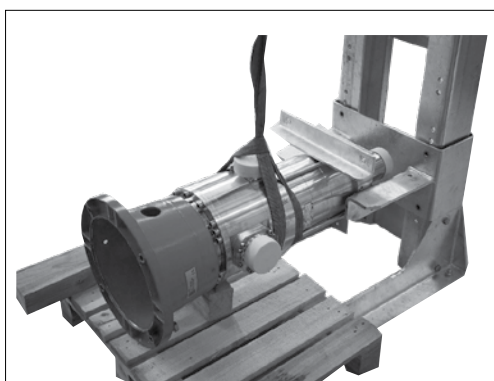

17. Secure with lifting equipment.

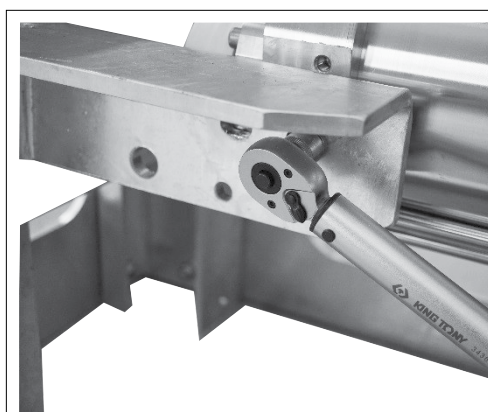

18. Loosen the last two screws on the frame.

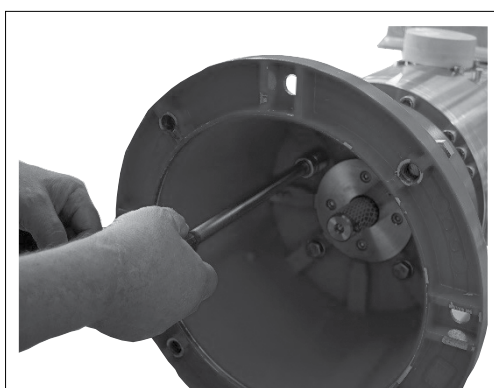

19. Loosen bell housing.

Mount in reverse order:

3. Disassembling horizontal base frame

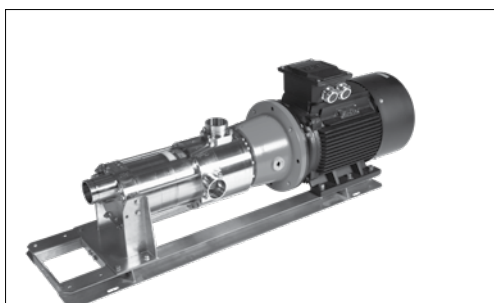

1. iSave on horizontal base frame.

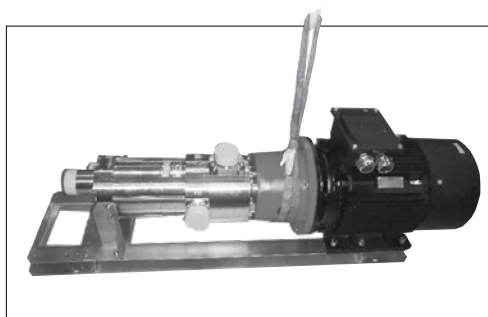

2. Support the iSave with lifting equipment.

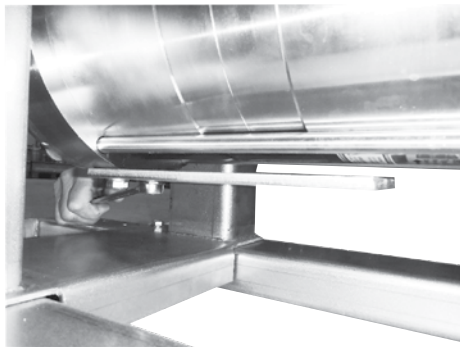

3. Dismount service bracket.

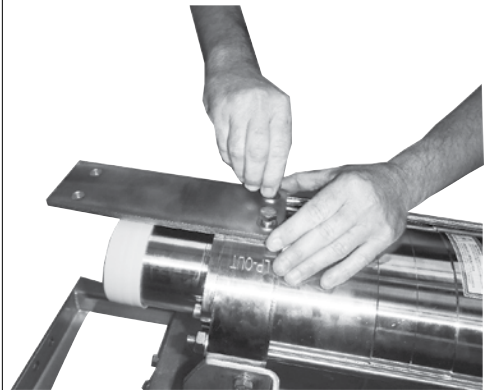

4. Install service mount on the top of the iSave.

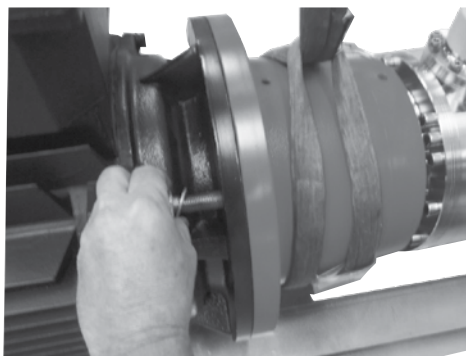

5. Remove screws between motor and bell housing.

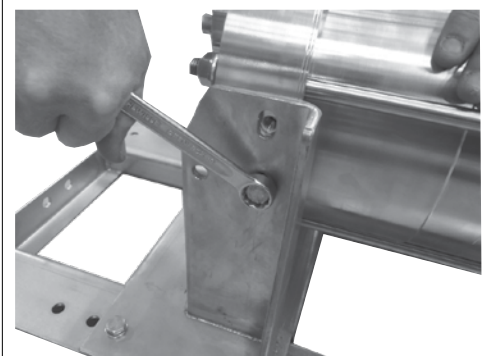

6. Remove upper screws on both sides.

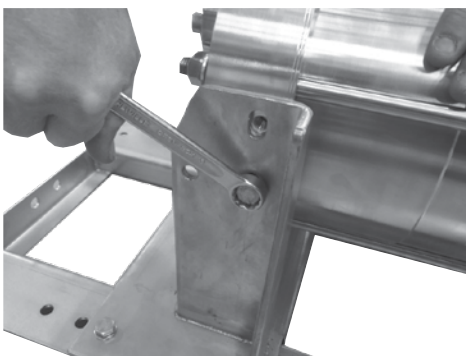

7. Loosen the other screws on both sides one full turn.

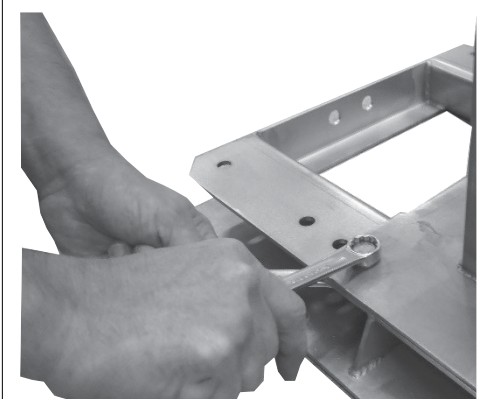

8. Remove four screws from bracket.

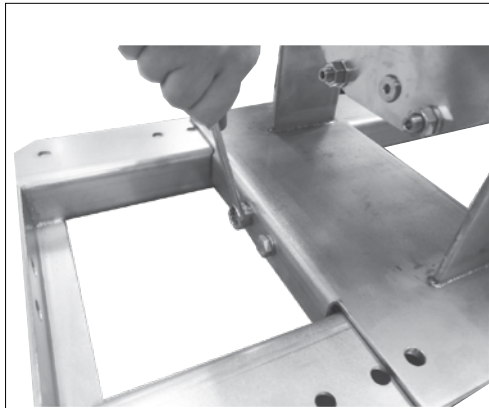

9. Remove the two screws for service bracket.

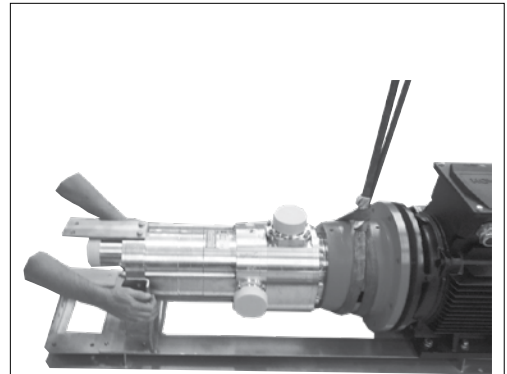

10. While supporting with lifting equipment, pull iSave away from the motor.

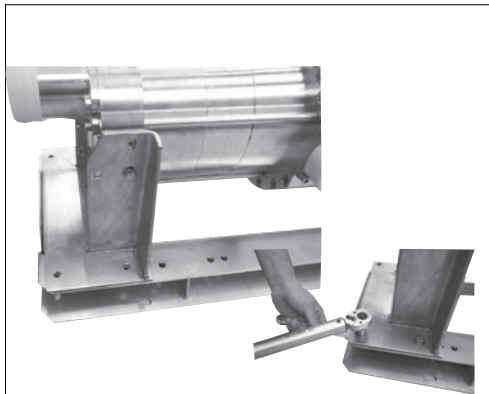

11. Align the bracket with the holes and install the screws to keep the bracket in place.

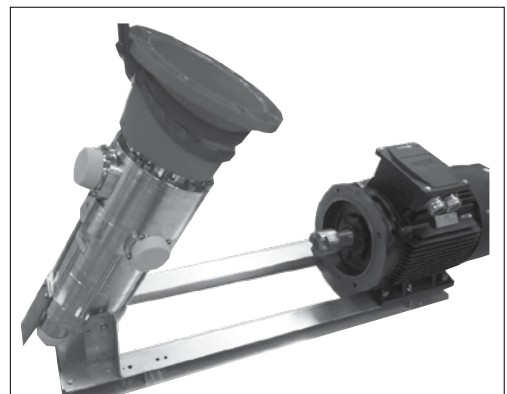

12. Slowly tip the iSave up in a vertical position.

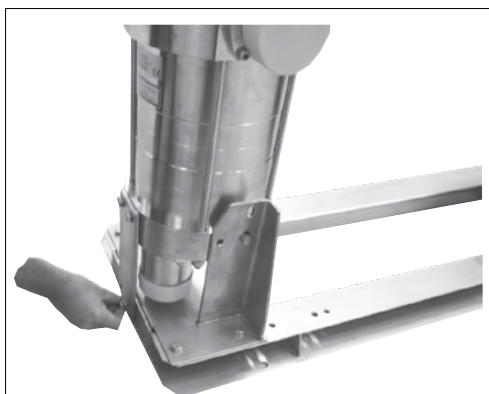

13. Install the screws to fix the iSave in the vertical position..



14. Tighten the screws with 30Nm..

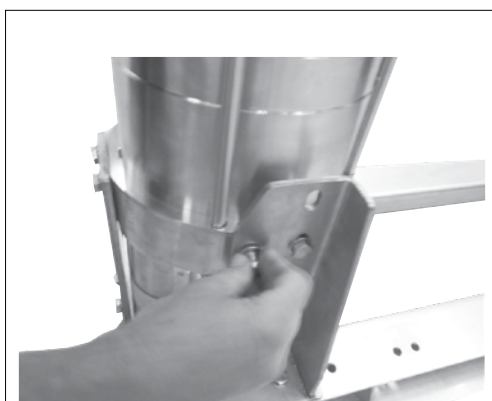

15. Install the screws for the bracket.

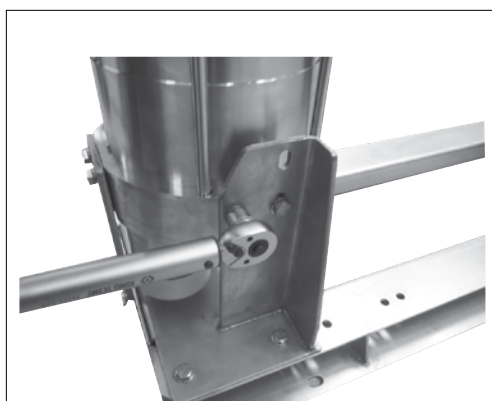

16. Tighten the remaining 4 screws on the bracket.

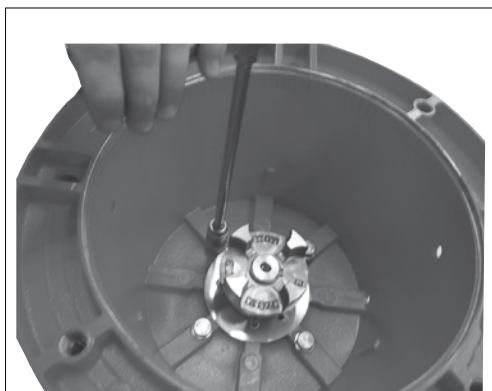

17. Loosen bell housing.

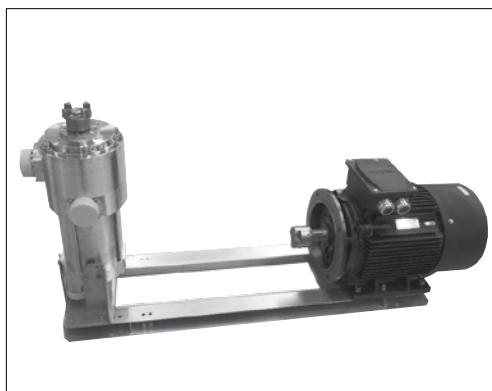

18. The iSave is now ready to be serviced.

Mount in reverse order

4. Disconnect the isave from the electric motor



1. For the vertical version mounted on the Danfoss base frame, safely mount lifting straps around the electrical motor to ensure straight vertical lifting. See Operation guide, chapter 4.

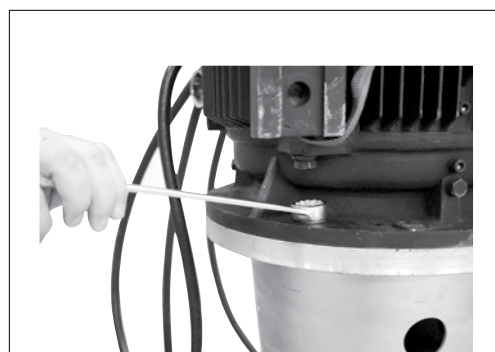

2. Unscrew the 4 bolts on the electrical motor using a 24 mm wrench.



3. Carefully lift the electrical motor straight up and away from the iSave. Place the electrical motor safely horizontal or vertically between 2 brackets. **(Don't place it on the coupling !!!)**

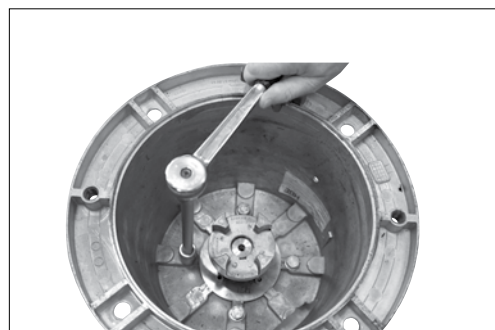

4. Unscrew the 4 bolts inside the bell housing and remove the bolts and washers using a 19 mm socket and extension tool.



5. Carefully remove the bell housing from the iSave.



6. Measure the distance between shaft seal flange and the coupling to be able to reassemble it back to the same distance.



7. Loosen the screw in the coupling using a 4 mm allen key for a "European coupling". Carefully remove the coupling without damaging the shaft (sometimes a puller is needed). Remove the key in the shaft.

5. Disassembling the booster / vane pump



1. Disassemble the shaft seal flange by unscrewing the 4 bolts using a 6 mm allen key or socket.



2. If the shaft seal flange can't be removed easily, screw in 2 x M8 bolts which will push out the shaft seal flange.

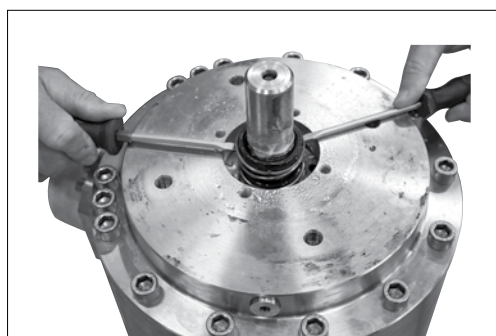

3. Lubricate the Shaft seal with clean filtered water and carefully remove the shaft seal using 2 screwdrivers.

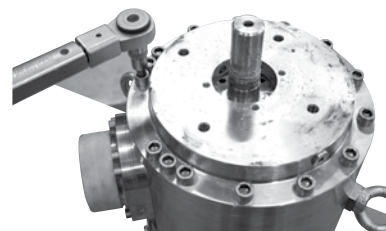

4. Unscrew the 15 bolts from the motor flange using a 10 mm allen key or socket.



5. Mount 2 x eyebolts in 2 of the M12 holes and carefully remove the motor flange and place it carefully with the bearing side upwards.



6. Visually check the side plate, rotor stop and motor flange surface for wear and scratches.

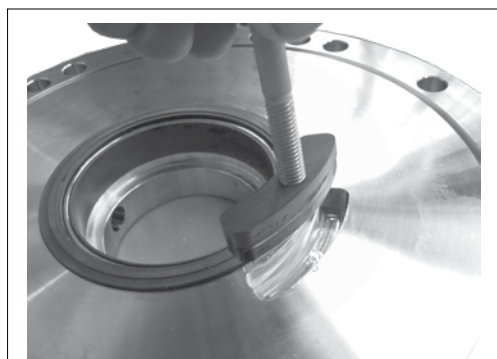

7. Remove the rotor stop by hand only using a M8 screw.

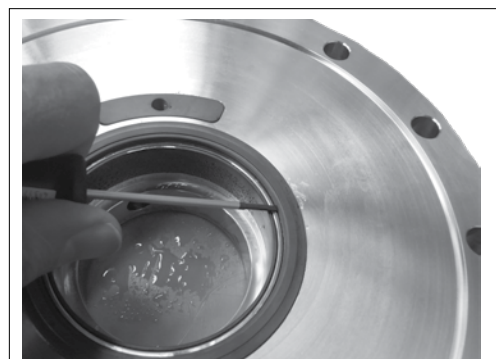

8. Carefully remove the side plates using a small screwdriver.

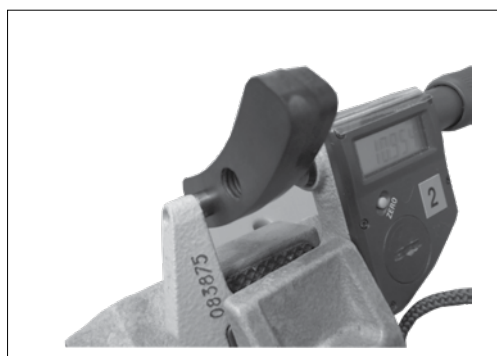

9. Check the rotor stop thickness using a micrometer. Replace if below 10,80 mm.

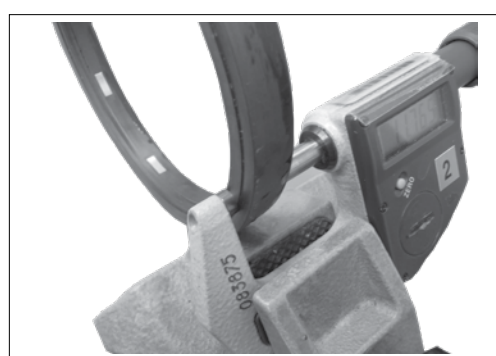

10. Check the side plates thickness using a micrometer. Replace if below 11,55 mm.

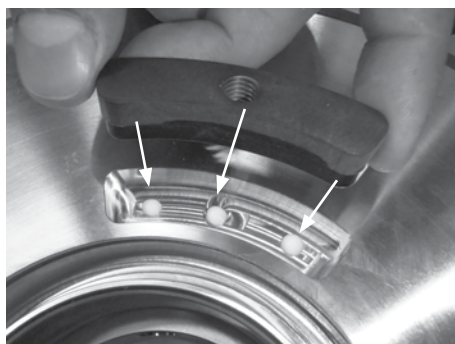

11. Put a small amount of lubricant in the hole. Lubricate the rotor stop and hole with clean filtered water and carefully by hand press in the rotor stop.

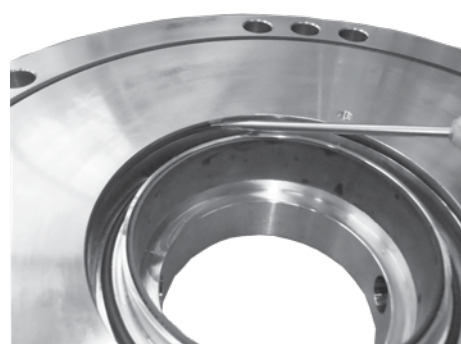

12. Lubricate the O-rings, side plate and flange with clean filtered water. Mount the first O-ring in the cut out in the flange.



13. Mount the second new O-ring in the bottom on the flange.

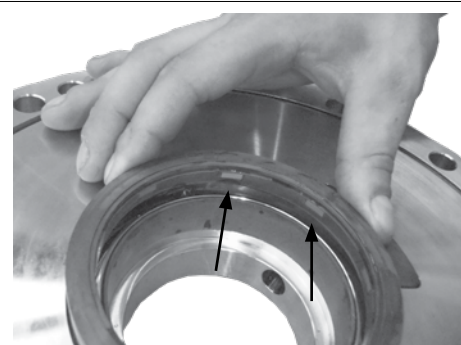

14. It is important that the inside groove in the side plates are pointing upwards



15. Carefully by hand only press down the side plate.
Always change rotor stop and side plate at the same time as changing the rotor elements.

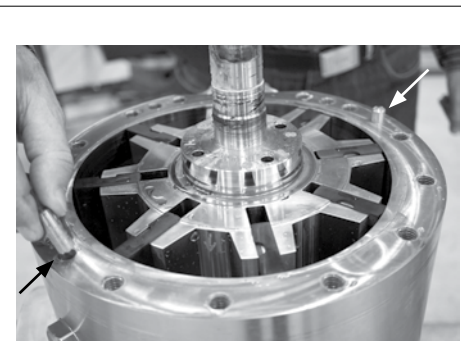

16 Remove the 2 pins in the stator housing.



17. Mount the M8 lifting eye in the rotor shaft end.

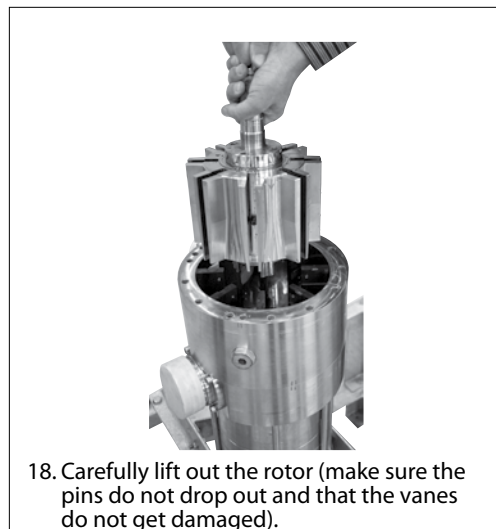

18. Carefully lift out the rotor (make sure the pins do not drop out and that the vanes do not get damaged).

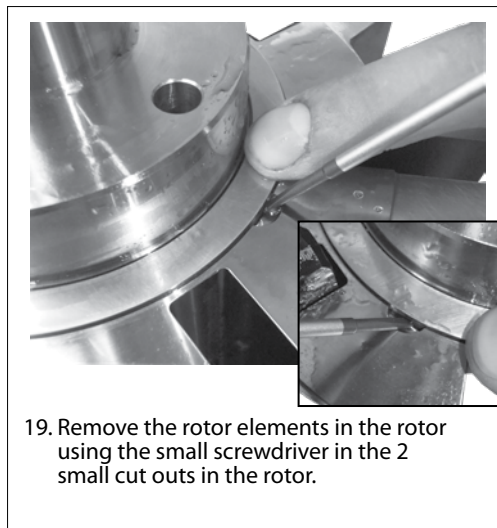

19. Remove the rotor elements in the rotor using the small screwdriver in the 2 small cut outs in the rotor.

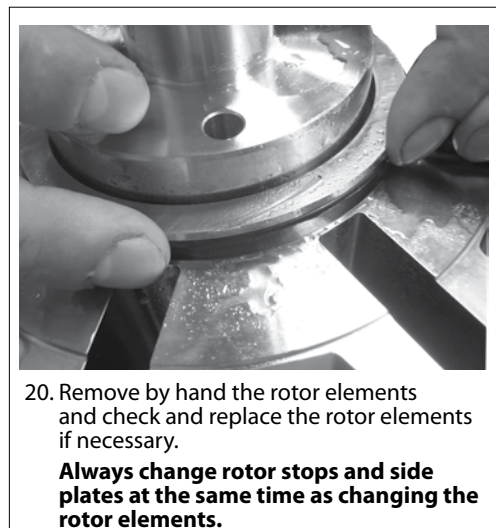

20. Remove by hand the rotor elements and check and replace the rotor elements if necessary.

Always change rotor stops and side plates at the same time as changing the rotor elements.

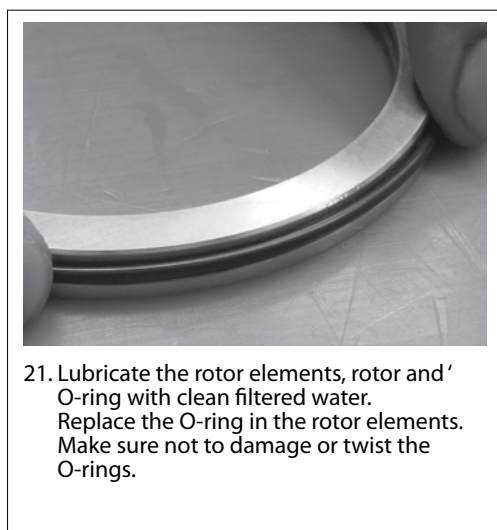

21. Lubricate the rotor elements, rotor and O-ring with clean filtered water. Replace the O-ring in the rotor elements. Make sure not to damage or twist the O-rings.

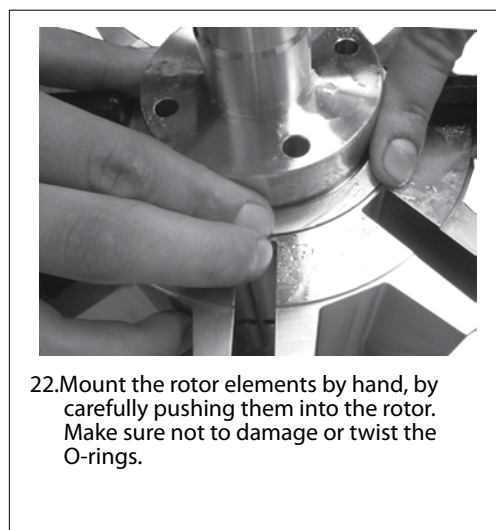

22. Mount the rotor elements by hand, by carefully pushing them into the rotor. Make sure not to damage or twist the O-rings.

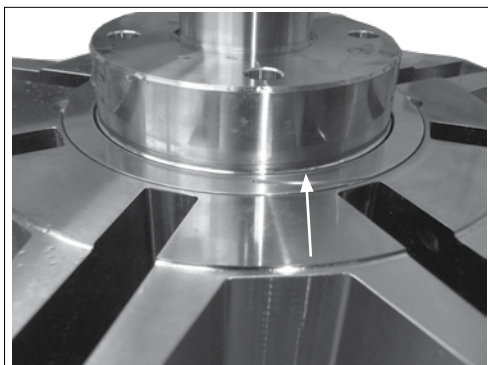

23. The rotor elements can only be pushed in until the surface is slightly above the rotor surface. There is **not** any special placement of the grooves in the rotor elements.

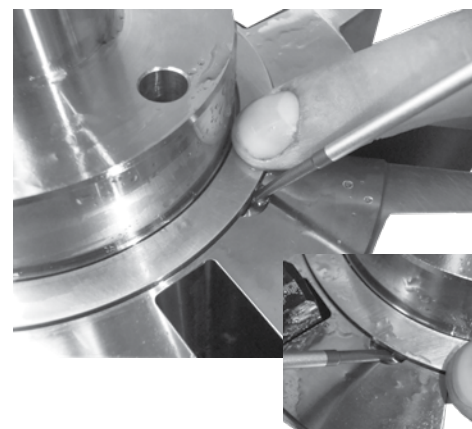

24. The O-ring will try to slip out in the 2 cut out holes. Carefully press it in with a small screwdriver.

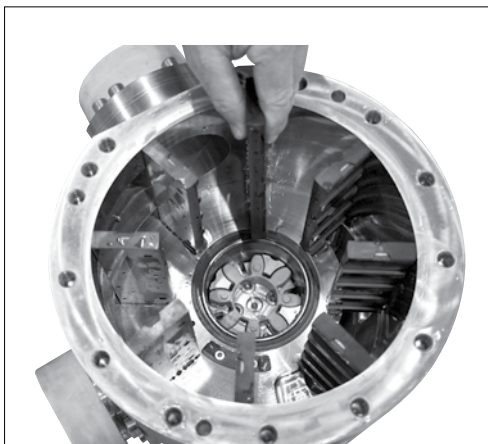

25. Remove the 8 vanes from the stator housing.



26. Remove the green spider from the internal coupling.



4 x special M8x20 bolts marked 1.4410

27. Unscrew the four special M8x20 bolts marked 1.4410. using the 6 mm allen socket.



28. Remove the coupling from the cylinder shaft. If sticking, screw in 2 x M5 bolts (not in tool kit) which will allow a better grip to pull out the coupling.

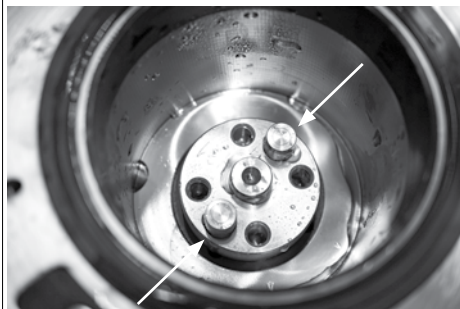

29. Remove the 2 pins in the cylinder shaft end.



30. Mount 2 lifting eyes across from each other in the stator housing to equal the weight and use a lifting strap to lift the stator housing.

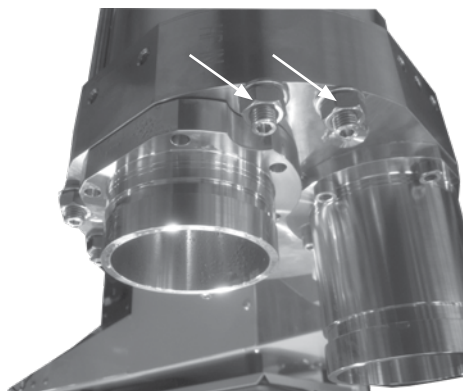

31. Unscrew the stud bolt nuts below the exchange connection flange using a 19 mm socket.



32. Remove the nuts and washers (the stud bolts may get loose and fall down).

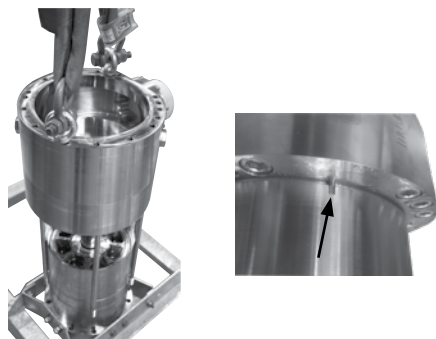

33. Carefully lift away the stator housing incl. the intermediate flange and port plate which is fixed on the intermediate flange and the stud bolts. (The small pin may fall out).



34. Unscrew the stud bolts using a 6 mm allen key to avoid the stud bolts get bended before placing the stator housing horizontally.



35. Unscrew and remove the lifting eyes and lifting strap and turn the stator housing up so that the port plate is upwards to avoid damage.

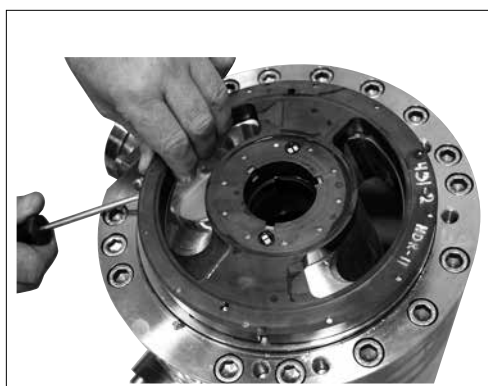

36. Remove the port plate from the 2 clips using a screwdriver.

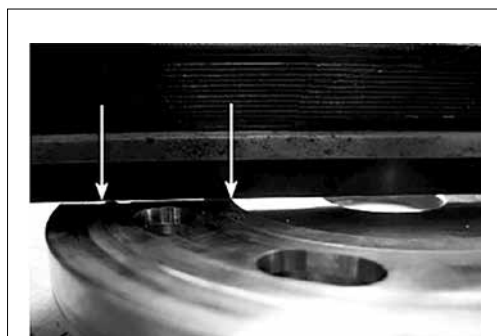

37. Visually check the port plate for wear/scratches and using a straight edge ruler across the sealing surfaces and replace if needed.

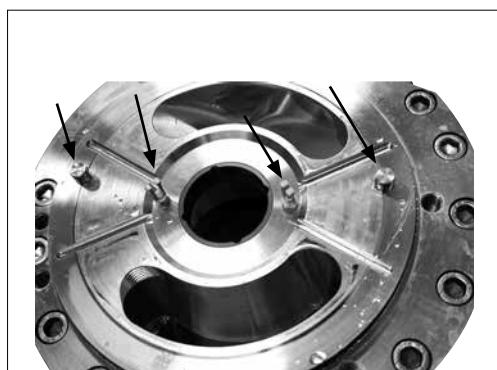
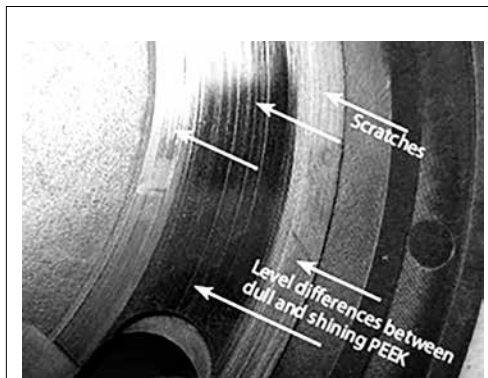

38. Remove the 2 clips, 2 pins and the O-ring.



39. Remove the small pin for fixing the exchanger housing in the intermediate flange.

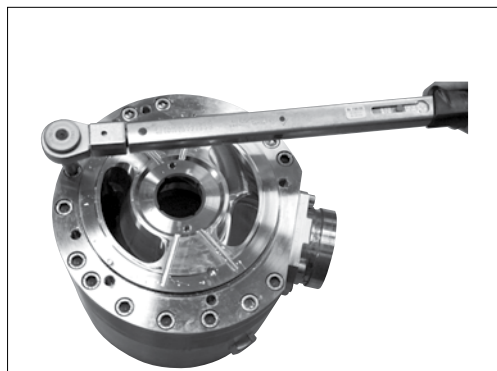

40. Unscrew the 15 bolts in the intermediate flange using a 10 mm allen key or socket.



41. Mount 2 lifting eyes across from each other in the intermediate flange to equal the weight and use a lifting strap to lift the flange away from the stator housing.



42. Remove the lifting eyes and strap and place the intermediate flange with the bearings side upwards.



43. Visually check all the intermediate flange bearings for wear/scratches. Replace the O-ring.

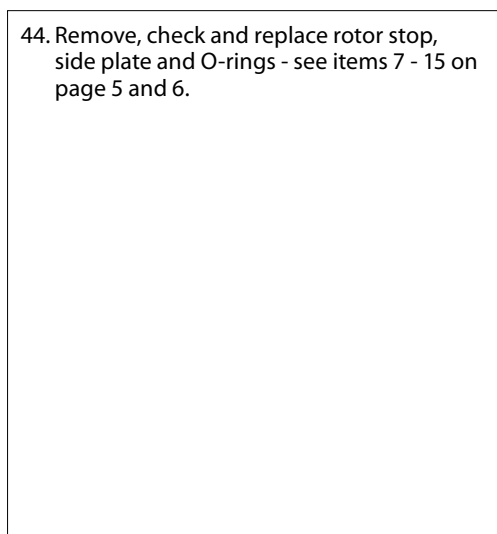

44. Remove, check and replace rotor stop, side plate and O-rings - see items 7 - 15 on page 5 and 6.

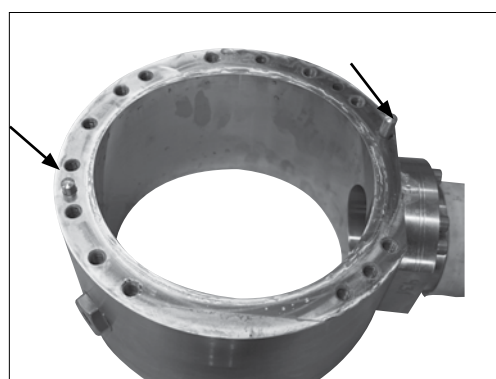

45. Remove the 2 pins from the stator housing.

6. Disassembling the pressure exchanger



1. Mount the M8 lifting eye on the cylinder barrel shaft end and carefully lift the cylinder barrel out of the housing using lifting equipment. (The weight of the cylinder barrel is about 32 kg).



2. Place the cylinder barrel horizontal and secure it can't roll and remove the lifting eye.



3. Disassemble the 2 valve plates by screwing in 2 x M8 bolt in the 2 holes with threads which press out the valve plate.

Changing springs in the cylinder barrel.

It is not necessary to change the springs in the cylinder barrel. If needed follow the guidelines below:



3.1 Disassemble the spring cover using 2 x M6 screws with 2 nuts and 2 washers and first tighten the screws to max. 10 Nm. Cross tighten the nuts until the O-ring is fully visual.



3.2 Carefully disassemble or cut the O-ring with the small screwdriver and unscrew the 2 x screws, 2 nuts and 2 washers.



3.3 Remove the spring cover by hand and check and replace springs if necessary.
Assembling:
 Lubricate the thread holes in the cylinder barrel with lubrication and mount the spring cover by hand over the springs.



3.4 Screw in the 2 x M6 screws with 2 x nuts and 2 washers and tighten the screws to max. 10 Nm. Cross tighten the nuts to press down the spring cover



3.5 Lubricate the new O-ring and cylinder shaft with clean filtered water and mount the new O-ring by hand in the O-ring groove. Remove the 2 x M6 screws with nuts and washers.

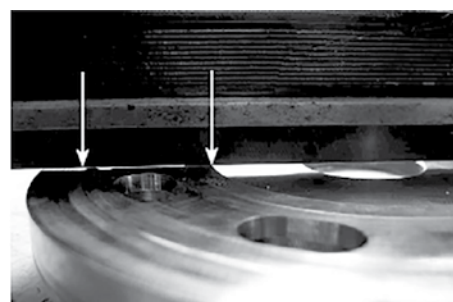

4. Visually check both the valve plates sealing surface for wear/scratches and use a straight edge ruler across the sealing surface and replace if needed.



5. Lubricate the back-up rings, O-rings and the valve plates with clean filtered water. Replace the back-up rings and O-rings on the valve plates (back-up ring first).
Make sure back-up rings are not twisted.



6. Calibrate the back up rings using the plastic tool from the tool set, before mounting the O-rings.
Proper mounting is very important!!!

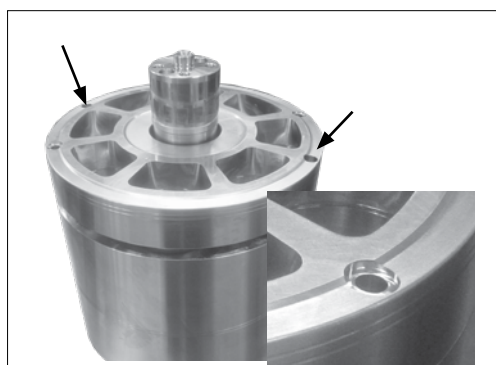

7. Lubricate the back-up rings, O-rings and the holes in the cylinder barrel with clean filtered water. Place the valve plates with the 2 holes with the undercut over the 2 thread holes in the cylinder barrel.



8. Mount the 2 x M6 nuts, 2 x M6 washers and bushings for valve plate on the 2 x M6 screws and then mount them (only by hand) in the holes with the undercut. Mount 2 x M16 washers equally between the 2 screws at the big shaft end.



9. Cross tighten the 2 x M6 nuts to press down the valve plates equally. The valve plate at the small shaft end should be pressed all the way in until you feel a small resistance (max. 10 Nm). The valve plate at the big shaft end should only be pressed in until it is still possible to remove the 2 x M16 washers (2-3 mm space left). Remove the 2 x M6 screws with the nuts, washers and the bushings for valve plate.



10. Remove the exchanger housing from the port flange by carefully using a plastic hammer and remove the small pin. (The pin may fall out).

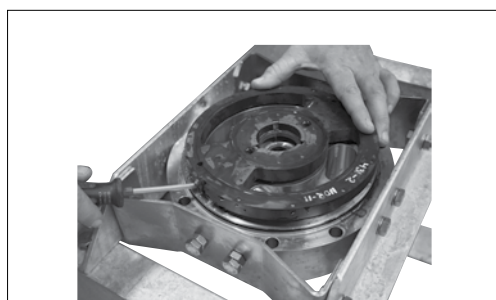

11. Remove the port plate from the 2 clips using a screwdriver.



12. Visually check the port plate for wear and scratches using a straight edge ruler across the sealing surfaces and replace if needed.

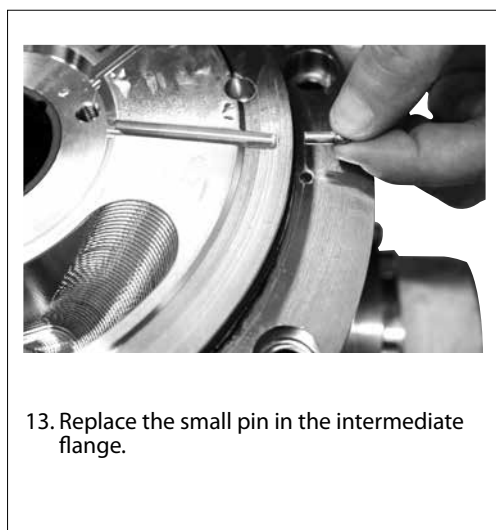
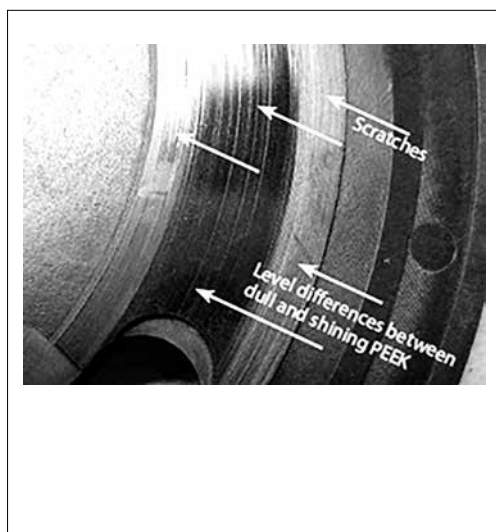

7. Assembling the pressure exchanger

WARNING:
Do not use silicone when assembling the iSave. Do not reuse disassembled O-rings and the shaft seal as they might be damaged. Always use new O-rings.

Important:
It is essential that the pump is serviced in conditions of absolute cleanliness. All parts must be completely clean before mounting.

Lubrication:

- To prevent seizing-up, lubricate all threads.
- It is important to lubricate ALL parts to be assembled with clean filtered water (Especially all PEEK parts).

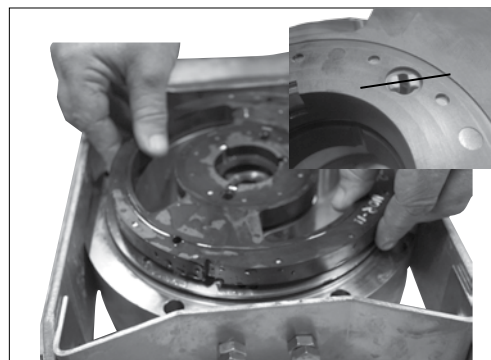

1. Lubricate the port flange and port plate with clean filtered water. Mount the port plate (brine) over the new clips and pins on the port flange. **Make sure that the clips are below the port flange surface.**

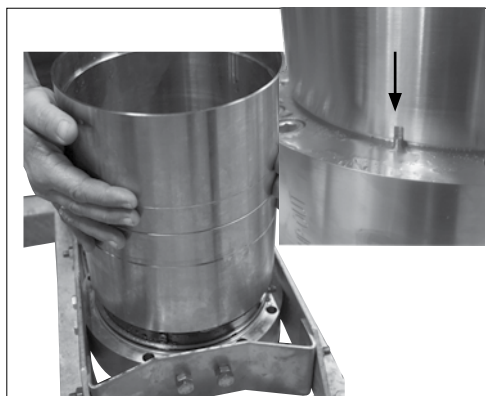

2. Check that the new small pin is still placed in the port flange and place the exchanger housing carefully over the small pin.



3. Mount the lifting eye on the cylinder barrel big shaft end and carefully lower the cylinder barrel straight into the exchanger housing using lifting equipment. (The weight of the cylinder barrel is about 32 kg). Afterwards remove the lifting eye.

WARNING:
If the cylinder barrel is dropped or lowered too fast into housing, the bearing in the Port flange might be damaged. Replacement can only be done at Danfoss, DK-Nordborg.

8. Assembling the booster/vane pump

WARNING:
Do not use silicone when assembling the iSave. Do not reuse disassembled O-rings; they might be damaged. Always use new O-rings.

Important:
It is essential that the pump is serviced in conditions of absolute cleanliness. All parts must be completely clean before mounting.

Lubrication:

- To prevent seizing-up, lubricate all threads.
- It is important to lubricate ALL parts to be assembled with clean filtered water (Especially all PEEK parts).

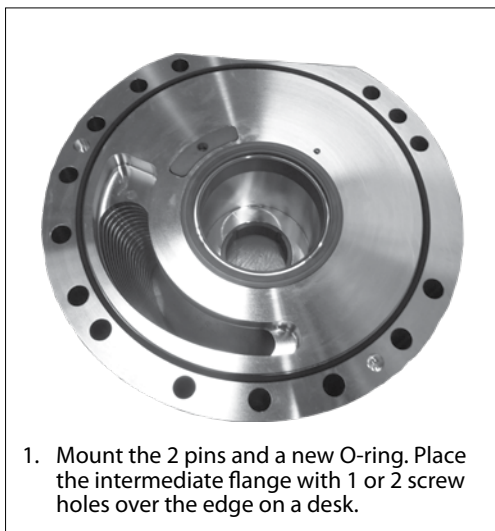

1. Mount the 2 pins and a new O-ring. Place the intermediate flange with 1 or 2 screw holes over the edge on a desk.

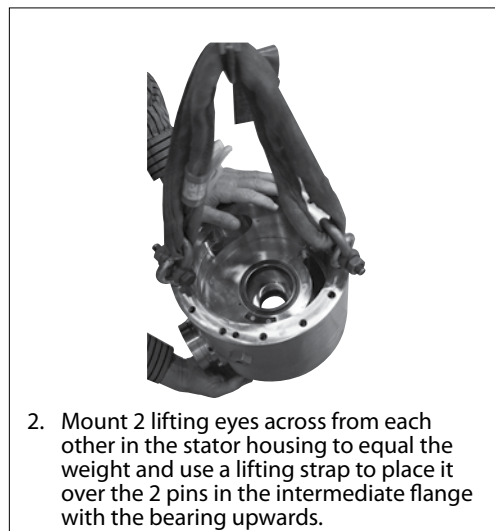

2. Mount 2 lifting eyes across from each other in the stator housing to equal the weight and use a lifting strap to place it over the 2 pins in the intermediate flange with the bearing upwards.

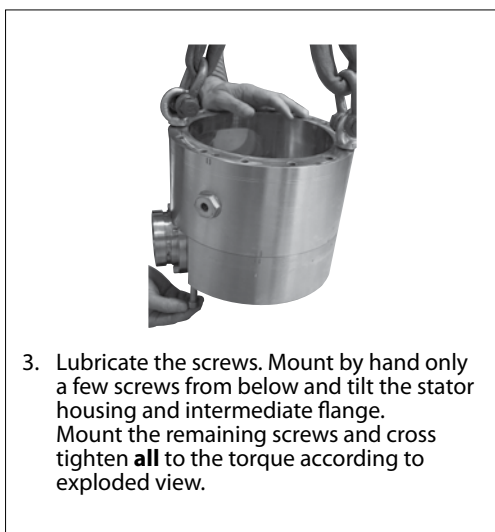

3. Lubricate the screws. Mount by hand only a few screws from below and tilt the stator housing and intermediate flange. Mount the remaining screws and cross tighten **all** to the torque according to exploded view.

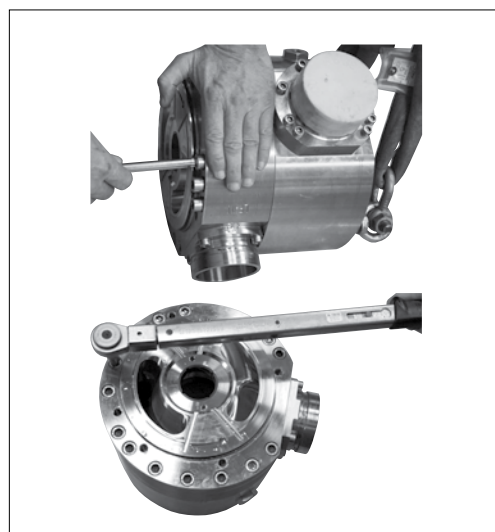

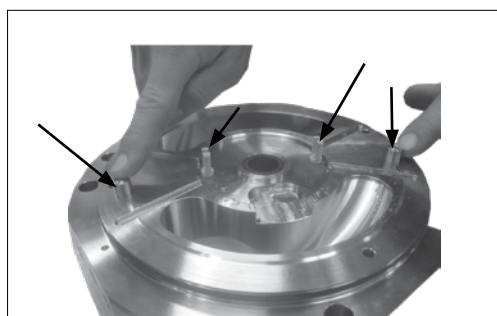

4. Lubricate small pin and the small pin hole and mount 2 new clips, 2 new pins and a new O-ring on the intermediate flange.

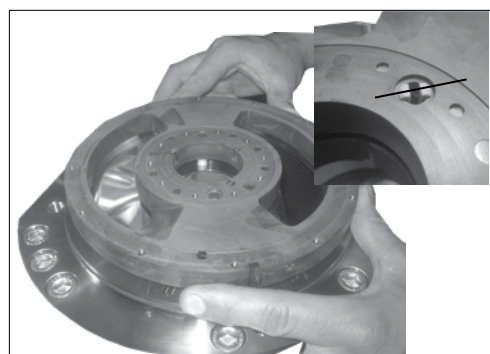

5. Lubricate the intermediate flange and port plate (feed) with clean filtered water and mount the port plate (feed) over the clips and pins.
Make sure that the clips are below the port flange surface.

9. Continue assembling the pressure exchanger

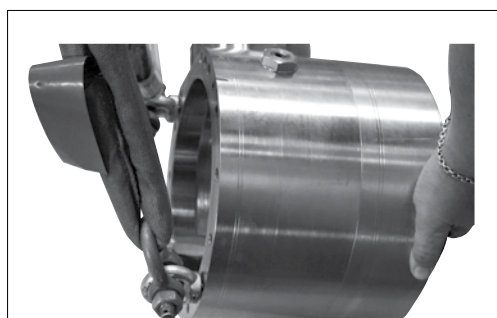

1. Lubricate the stud bolt. Tilt the stator housing and the intermediate flange with the port plate mounted horizontally. Mount the stud bolts in the intermediate flange and tighten to the torque according to exploded view.



2. Mount 2 lifting eyes across from each other in the stator housing to equal weight. Carefully lower the stator housing into the 6 stud bolt holes and small pin. Remove the 2 lifting eyes and the lifting strap.

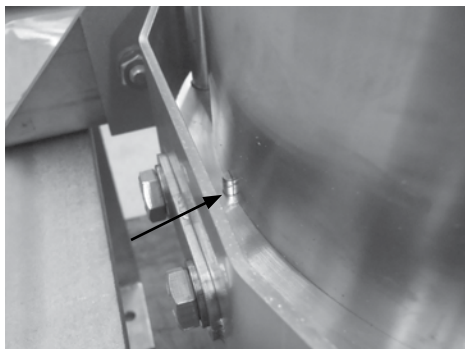

3. Check that the small pin is in correct position.



4. Lubricate the stud bolt threads. Mount the 6 Stud bolt washer and nuts below the exchange connection flange.

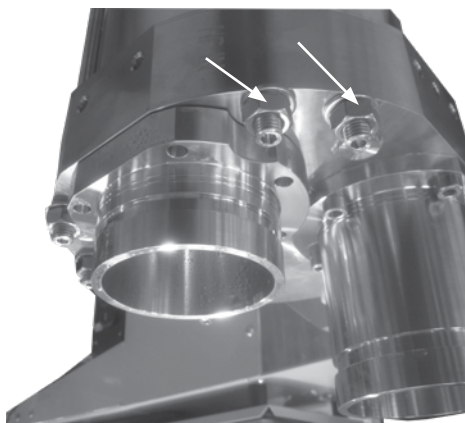

5. Cross tighten to the torque according to exploded view.



6. Mount the 2 pins in the cylinder shaft end.



4 x special M8x20 bolts marked 1.4410

7. Lubricate the coupling screw. Mount one internal coupling part and mount the four special M8x20 bolts marked 1.4410.

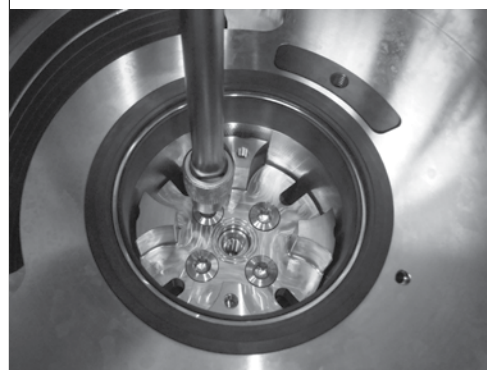

8. Cross tighten to the torque according to exploded view.



9. Mount the green spider inside the internal coupling.

10. Continue assembling the booster/vane pump

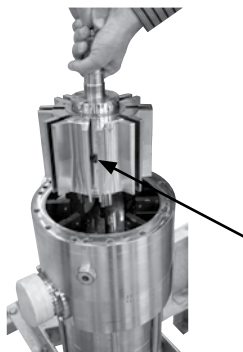

1. Mount a lifting eye in the rotor shaft end and mount the 8 pins inside the rotor.



2. Carefully lower the rotor straight into the stator housing, internal coupling and green spider.



3. Remove the lifting eyes and mount the 2 pins in the stator housing.

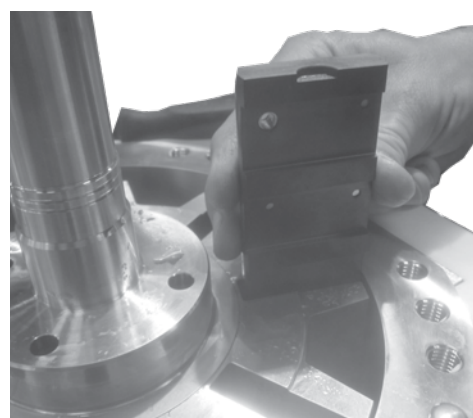

4. Lubricate the vanes and the rotor slides with clean filtered water.

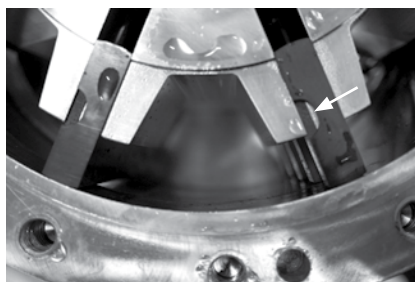

5. Mount the 8 vanes. (Steel inside vanes should be visible clock wise to the shaft center.)

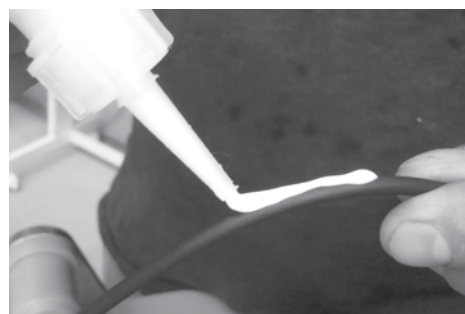

6. Apply a thin layer of lubrication (not water) on the O-ring for the motor flange.



7. Make sure to mount the O-ring correctly in the groove so that it does not twist. Remove excess lubrication from the motor flange. This is to keep the O-ring in place when turning the flange upside down.



8. Mount 2 x eyebolts in 2 of the M12 holes in the motor flange and carefully lower the motor flange on the stator housing and the 2 pins. (Be carefully not to scratch the bearings).

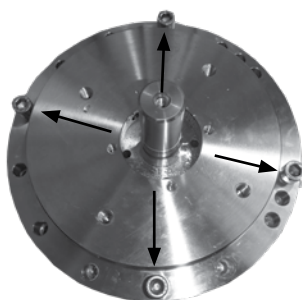

9. Lubricate all the screws but first mount only 4 screws that are evenly placed around the motor flange.



10. By hand only carefully cross tighten the 4 screws (max. 10Nm) to ensure the motor flanges are tightened evenly onto the stator housing.

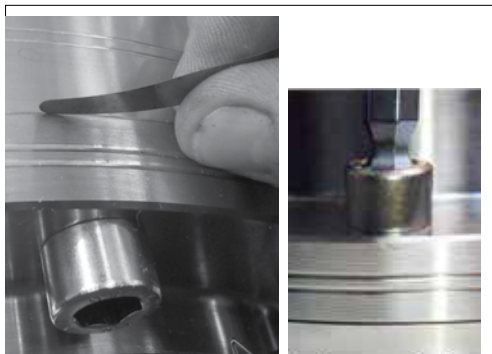

11. Check with a 0.05 mm feeler gauge that there is **no** gap between the motor flange and stator housing. If there is a gap loosen one or more screws and retighten them again.

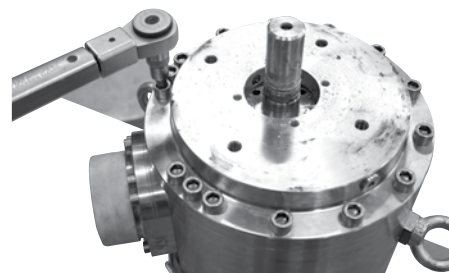

12. Mount the remaining 11 screws in the motor flange and cross tighten **all** the screws to the torque according to exploded view.



13. Only lubricate the new shaft seal with clean filtered water and mount the shaft seal over the shaft end with the carbon ring upwards.



14. Press down the shaft seal to the shoulder/recess of the shaft using the plastic press bush tool.



15. Remove the ceramic ring of the shaft seal in the shaft seal cover using a screwdriver.



16. Lubricate the new shaft seal with clean filtered water and press the new ceramic ring into the shaft seal cover using the plastic press bush tool.

Warning:
Ensure that the face with rubber seal is positioned against shoulder/recess in shaft seal cover and the ceramic ring upwards.



17. Lubricate the screws. Mount a new O-ring on the shaft cover and mount it on the motor flange. Tighten the screws to the torque according to exploded view.

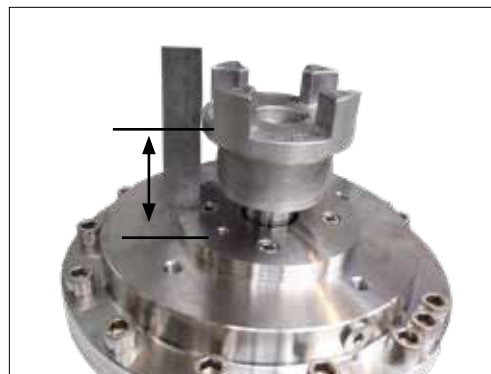

18. Lubricate the shaft. Mount the key in the shaft end and mount the coupling. Adjust the coupling and flange distance to the same as measured before the disassembling.



19. Tighten the screw inside the coupling to the torque according to exploded view.



20. Mount the spider and the bell housing over the shaft seal cover outside diameter.

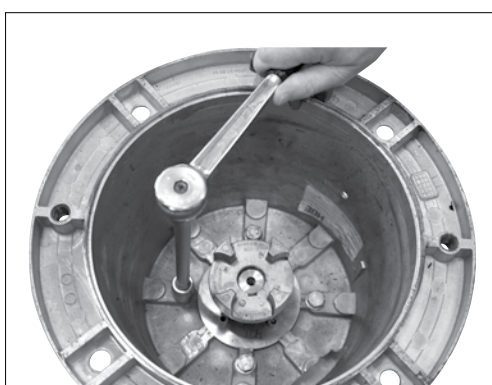

21. Lubricate the 4 screws and mount the washers and screws inside the bell housing. Tighten the screws to the torque according to exploded view.

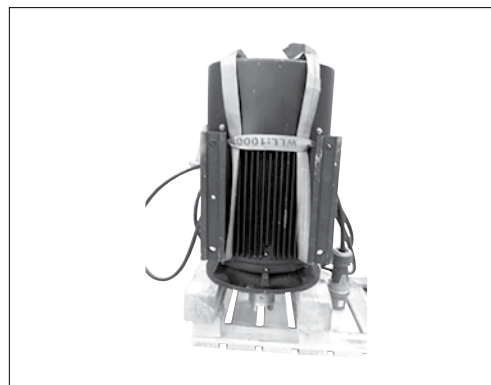

22. Carefully lift the electrical motor from the support.



23. Carefully lower it onto the iSave (turn the electrical motor coupling using a screwdriver through the inspection hole in the bell housing so it fits into the spider and the other coupling).

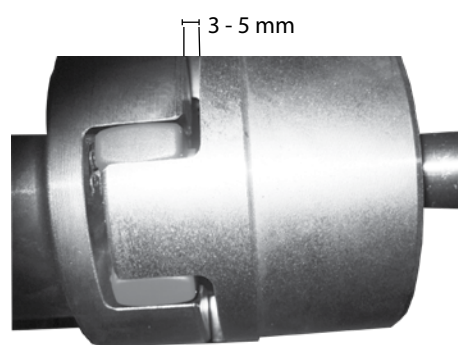

24. Check through the inspection hole in the bell housing that the coupling distance still has 3 - 5 mm free space.

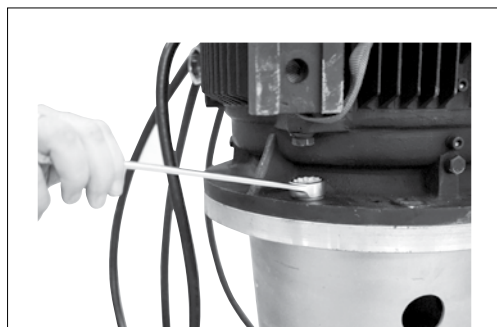

25. Lubricate the screws.
Mount the 4 screws and washers and tighten to the torque according to the drawings in chapter 10 and 11.



26. Remove the lifting straps. Mount all hoses or pipes to the iSave connectors and connect the electric cables correctly again.

Also remember to retighten all the screws and nuts on the base frame with the torque according to chapter 10 and 11.

12. iSave on baseplate, horizontal

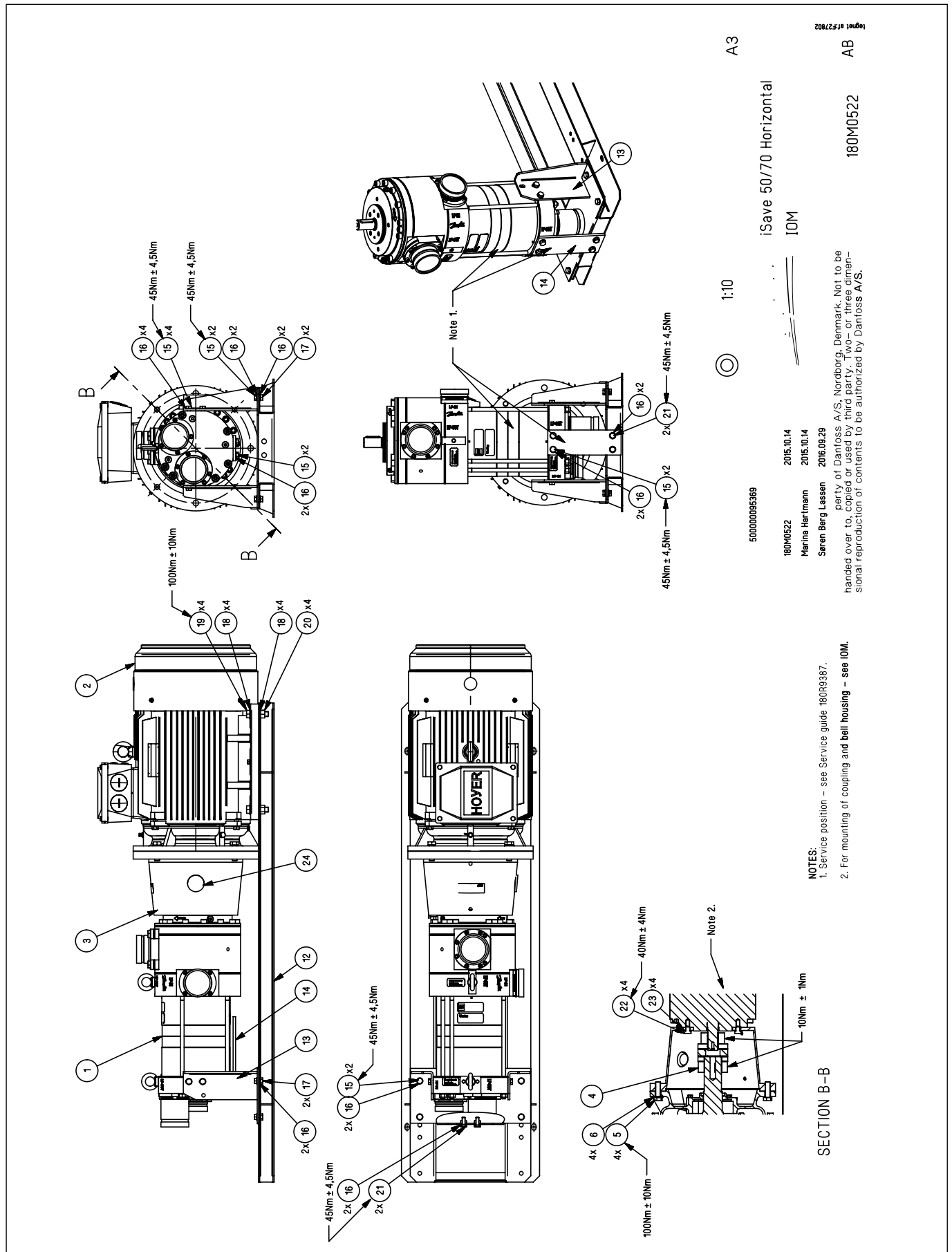

13. iSave on base frame, vertical

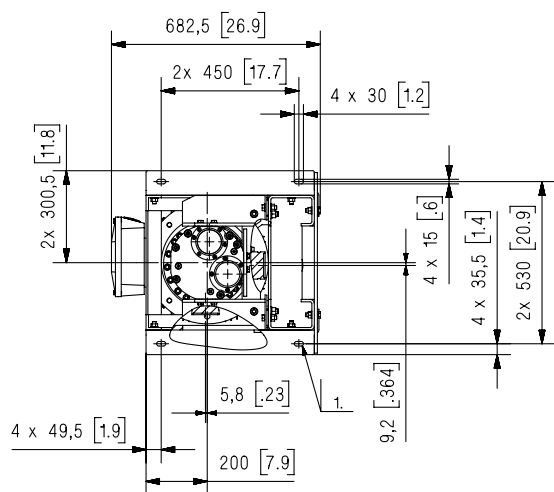

1. M12 anchoring/bolts.
Bolt quality min. class 8.8.
Torqued acc. to recommendation
from bolt supplier.
Foundation/anchoring acc. to
Eurocode 2: 1992-1-1.

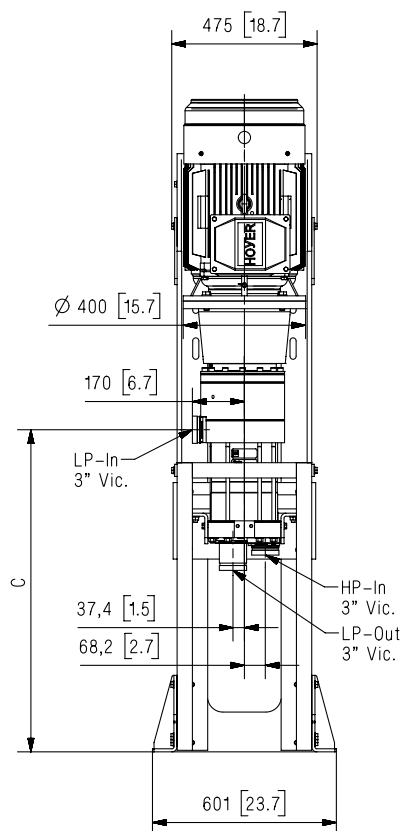
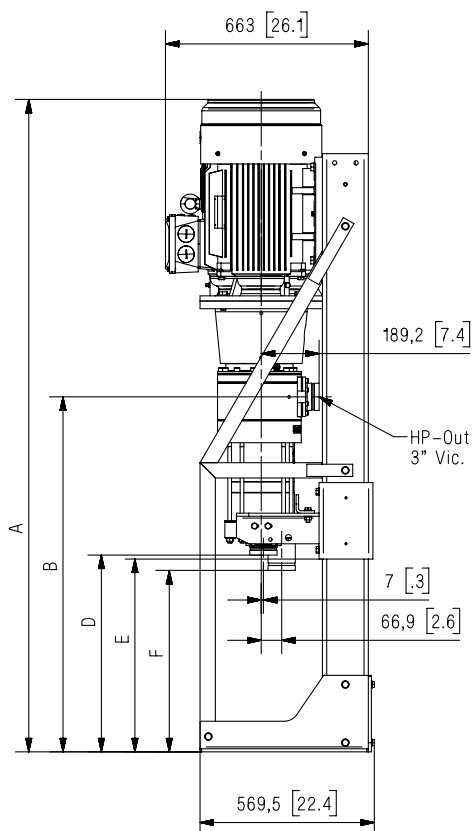

Dimensions without tolerances acc. to ISO 2768-1 designation C.
Positions 1, 2 and 3 refers to the three different heights where
the iSave can be mounted on the baseframe.

| Dimension | Position 1 | Position 2 | Position 3 * |
|-----------|---------------|---------------|---------------|
| A | 2132,3 [83.9] | 1979,8 [77.9] | 1827,3 [71.9] |
| B | 1160,2 [45.7] | 1007,7 [39.7] | 855,2 [33.7] |
| C | 1052,7 [41.4] | 900,2 [35.4] | 747,7 [29.4] |
| D | 643 [25.3] | 490,5 [19.3] | 338 [13.3] |
| E | 630 [24.8] | 477,5 [18.8] | 325 [12.8] |
| F | 593 [23.3] | 440,5 [17.3] | 288 [11.3] |

* Unit is delivered in position 3!

13.1 iSave on base frame, vertical cont.

100 Nm ± 10 Nm 8 x 27 27 x 8
4 x 28 29 x 4

SECTION D-D

100 Nm ± 10 Nm 4 x 5
40 Nm ± 4 Nm 4 x 6
4 x 22 4 x 23

SECTION B-B

4 10 Nm ± 1 Nm 1

SECTION A-A

60 Nm ± 6 Nm 25 x 6 26 x 6

SECTION C-C

Support frame front mounted

Support frame back mounted

1. For mounting of coupling and bell housing – see IOM.

| | | | | |
|--|------------------------------|------------|-------|-------------------------|
| 500000104648 | | Projection | Scale | Material |
| Mrk. KM(Approb./Rev.) | Date | | 1:10 | Danfoss Standard |
| Replace | | | | iSave50-70 Vertical IEC |
| Design | Marina Hartmann 2017.06.19 | | | IOM |
| Approb. | Søren Berg Lassen 2017.09.26 | | | |
| Confidential: Property of Danfoss A/S, Nordborg, Denmark. Not to be handed over to, copied or used by third party. Two- or three-dimensional reproduction of contents to be authorized by Danfoss A/S. | | | | No. 180M0534 AA |

Danfoss A/S
High Pressure Pumps
DK-6430 Nordborg
Denmark

Danfoss can accept no responsibility for possible errors in catalogues, brochures and other printed material. Danfoss reserves the right to alter its products without notice. This also applies to products already on order provided that such alterations can be made without subsequential changes being necessary in specifications already agreed.
All trademarks in this material are property of the respective companies. Danfoss and the Danfoss logotype are trademarks of Danfoss A/S. All rights reserved.
